

HYDRAULIC MOTORS MM



CONTENTS

Specification data	5
Function diagrams	6÷8
Dimensions and mounting ...	9÷10
Shaft extensions	11
Permissible shaft loads	11
Order code	12

APPLICATION

- » Conveyors
- » Textile machines
- » Mining machinery
- » Machine tools
- » Ventilators
- » Construction plant equipment and access platforms etc.

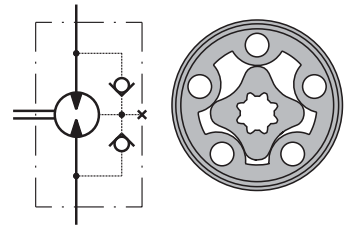

Pressure Settings at Flow Q=.53 GPM [2 lpm], 150 SUS [32 mm²/s], 50°C [122°F]

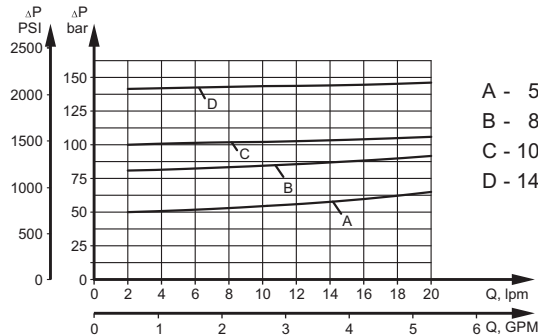

- A - 50 bar [725 PSI]
- B - 80 bar [1160 PSI]
- C - 100 bar [1450 PSI]
- D - 140 bar [2030 PSI]

OPTIONS

- » Model - Spool valve, gerotor
- » With or without flange
- » Side and rear ports
- » Series with pressure valve(s)
- » Shafts - straight and splined
- » Metric and BSPP ports
- » Speed sensing;
- » Other special features

MMP Series with Integrated Internal Crossover Relief Valve A → B, Δp=100 or 50 bar [1450 or 725 PSI]

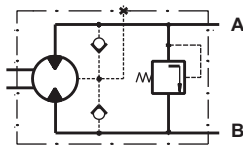

MMP Series with Integrated Internal Crossover Relief Valve B → A, Δp=100 or 50 bar [1450 or 725 PSI]

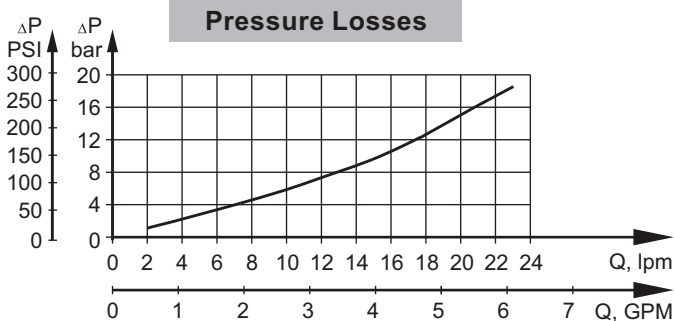
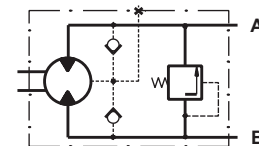

Pressure Losses

MMD Series with Integrated Internal Crossover Relief Valves A ↔ B, Δp=100 or 50 bar [1450 or 725 PSI]

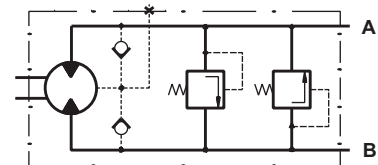

GENERAL

Max. Displacement,	cm ³ /rev [in ³ /rev]	50 [3.05]
Max. Speed,	[RPM]	2440
Max. Torque,	daNm [lb-in]	cont.: 4,5 [398] int.: 5,8 [513]
Max. Output,	kW [HP]	3,2 [4.3]
Max. Pressure Drop,	bar [PSI]	cont.: 105 [1500] int.: 140 [2030]
Max. Oil Flow,	lpm [GPM]	25 [6.6]
Min. Speed,	[RPM]	20
Pressure fluid		Mineral based- HLP(DIN 51524) or HM(ISO 6743/4)
Temperature range,	°C [°F]	-40÷140 [-40÷284]
Optimal Viscosity range,	mm ² /s [SUS]	20÷75 [98÷347]
Filtration		ISO code 20/16 (Min. recommended fluid filtration of 25 microns)

SPECIFICATION DATA

Type	MM 8	MM 12.5	MM 20	MM 32	MM 40	MM 50
Displacement, cm³/rev [in³/rev]	8,2 [50]	12,5 [77]	19,9 [1.22]	31,6 [1.93]	39,8 [2.43]	50 [3.08]
Max. Speed, [RPM]	Cont.	1950	1550	1000	630	500
	Int.*	2450	1940	1250	800	630
Max. Torque daNm [lb-in]	Cont.	1,1 [95]	1,6 [140]	2,5 [220]	4,0 [350]	4,5 [400]
	Int.*	1,5 [135]	2,3 [200]	3,5 [310]	5,7 [500]	7,0 [620]
	Peak**	2,1 [187]	3,3 [293]	5,1 [453]	6,4 [568]	8,2 [725]
Max. Output kW [HP]	Cont.	1,8 [2.4]	2,4 [3.2]	2,4 [3.2]	2,4 [3.2]	2,2 [3.0]
	Int.*	2,6 [3.5]	3,2 [4.3]	3,2 [4.3]	3,2 [4.3]	3,2 [4.3]
Max. Pressure Drop bar [PSI]	Cont.	100 [1450]	100 [1450]	100 [1450]	100 [1450]	90 [1310]
	Int.*	140 [2030]	140 [2030]	140 [2030]	140 [2030]	140 [2030]
	Peak**	200 [2900]	200 [2900]	200 [2900]	160 [2320]	160 [2320]
Max. Oil Flow lpm [GPM]	Cont.	16 [4.2]	20 [5.3]	20 [5.3]	20 [5.3]	20 [5.3]
	Int.*	20 [5.3]	25 [6.6]	25 [6.6]	25 [6.6]	25 [6.6]
Max. Inlet Pressure bar [PSI]	Cont.	140 [2030]	140 [2030]	140 [2030]	140 [2030]	140 [2030]
	Int.*	175 [2540]	175 [2540]	175 [2540]	175 [2540]	175 [2540]
	Peak**	225 [3260]	225 [3260]	225 [3260]	225 [3260]	225 [3260]
Max. Return Pressure without Drain Line or Max. Pressure in Drain Line, bar [PSI]	Cont. 0-100 RPM	140 [2030]	140 [2030]	140 [2030]	140 [2030]	140 [2030]
	Cont. 100-400 RPM	105 [1500]	105 [1500]	105 [1500]	105 [1500]	105 [1500]
	Cont. 400-800 RPM	50 [725]	50 [725]	50 [725]	50 [725]	50 [725]
	Cont. >800 RPM	20 [290]	20 [290]	20 [290]	-	-
Max. Return Pressure with Drain Line bar [PSI]	Int.* 0-max. RPM	140 [2030]	140 [2030]	140 [2030]	140 [2030]	140 [2030]
	Cont.	140 [2030]	140 [2030]	140 [2030]	140 [2030]	140 [2030]
	Int.*	175 [2540]	175 [2540]	175 [2540]	175 [2540]	175 [2540]
Max. Starting Pressure with Unloaded Shaft, bar [PSI]	Cont.	140 [2030]	140 [2030]	140 [2030]	140 [2030]	140 [2030]
	Int.*	175 [2540]	175 [2540]	175 [2540]	175 [2540]	175 [2540]
Min. Starting Torque daNm [lb-in]	Peak**	225 [3260]	225 [3260]	225 [3260]	225 [3260]	225 [3260]
	Cont.	4 [60]	4 [60]	4 [60]	4 [60]	4 [60]
Min. Starting Torque daNm [lb-in]	At max. press. drop Cont.	0,7 [60]	1,2 [105]	2,1 [185]	3,4 [300]	3,8 [335]
	At max. press. drop Int.*	1,0 [90]	1,7 [150]	2,9 [255]	4,8 [425]	6,2 [550]
Min. Speed***, [RPM]	50	40	30	30	25	20
Weight, kg [lb] For "F" flange: + 0,200 [.441]	MM	1,9 [4.2]	2,0 [4.41]	2,1 [4.63]	2,2 [4.85]	2,3 [5.07]
	MMF(S)	2,0 [4.41]	2,1 [4.63]	2,2 [4.85]	2,3 [5.07]	2,4 [5.29]
	MMP	2,2 [4.85]	2,3 [5.07]	2,4 [5.29]	2,5 [5.51]	2,6 [5.73]
	MMD	2,6 [5.73]	2,7 [5.95]	2,8 [6.17]	2,9 [6.39]	3,0 [6.61]

* Intermittent operation: the permissible values may occur for max. 10% of every minute.

** Peak load: the permissible values may occur for max. 1% of every minute.

*** For speeds lower than given, consult factory or your regional manager.

1. Intermittent speed and intermittent pressure must not occur simultaneously.
2. Recommended filtration is per ISO cleanliness code 20/16. A nominal filtration of 25 micron or better.
3. Recommend using a premium quality, anti-wear type mineral based hydraulic oil HLP(DIN51524) or HM (ISO 6743/4).
If using synthetic fluids consult the factory for alternative seal materials.
4. Recommended minimum oil viscosity 13 mm²/s [70 SUS] at 50°C [122°F].
5. Recommended maximum system operating temperature is 82°C [180°F].
6. To assure optimum motor life fill with fluid prior to loading and run at moderate load and speed for 10-15 minutes.

FUNCTION DIAGRAMS

MM 8

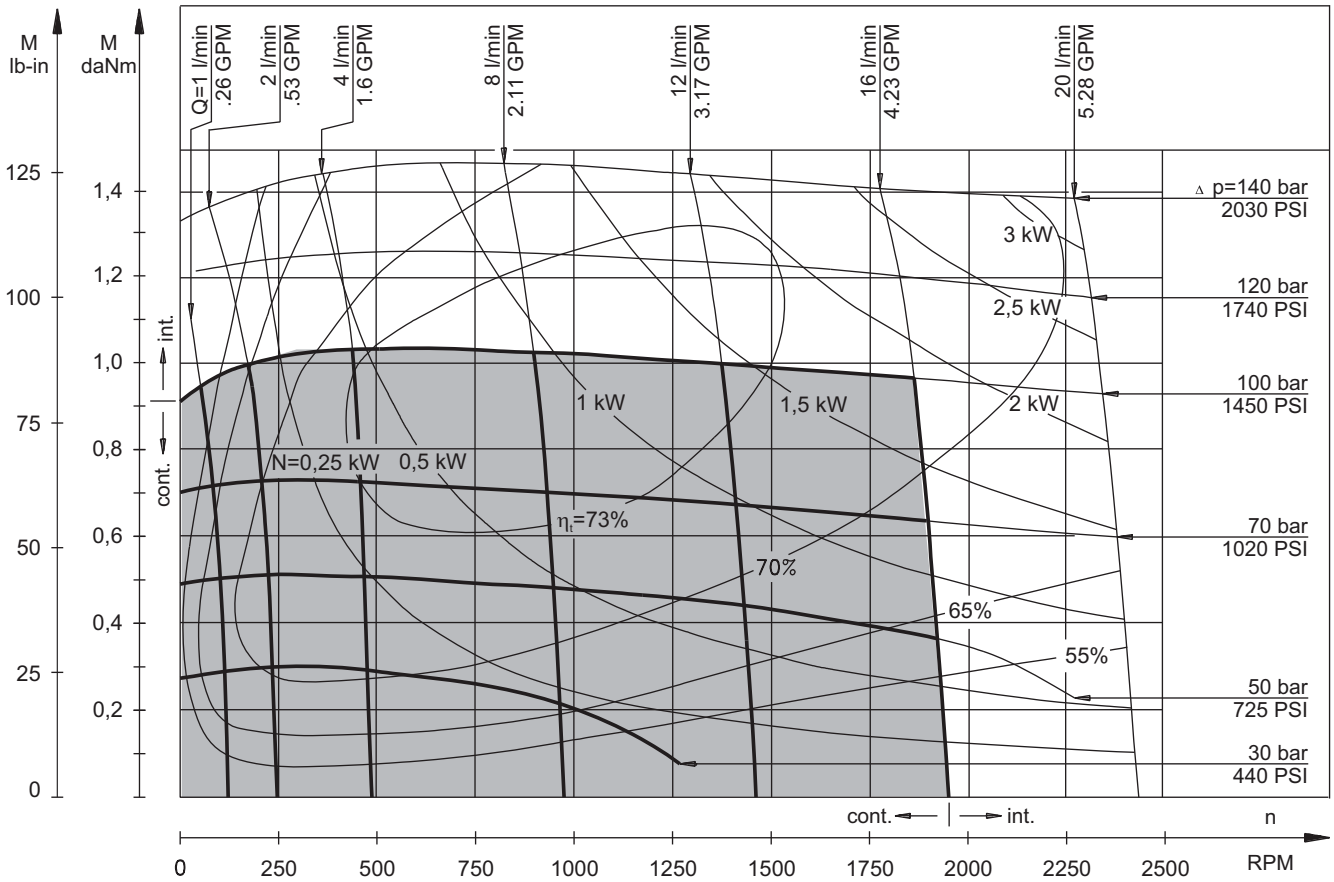

MM 12,5

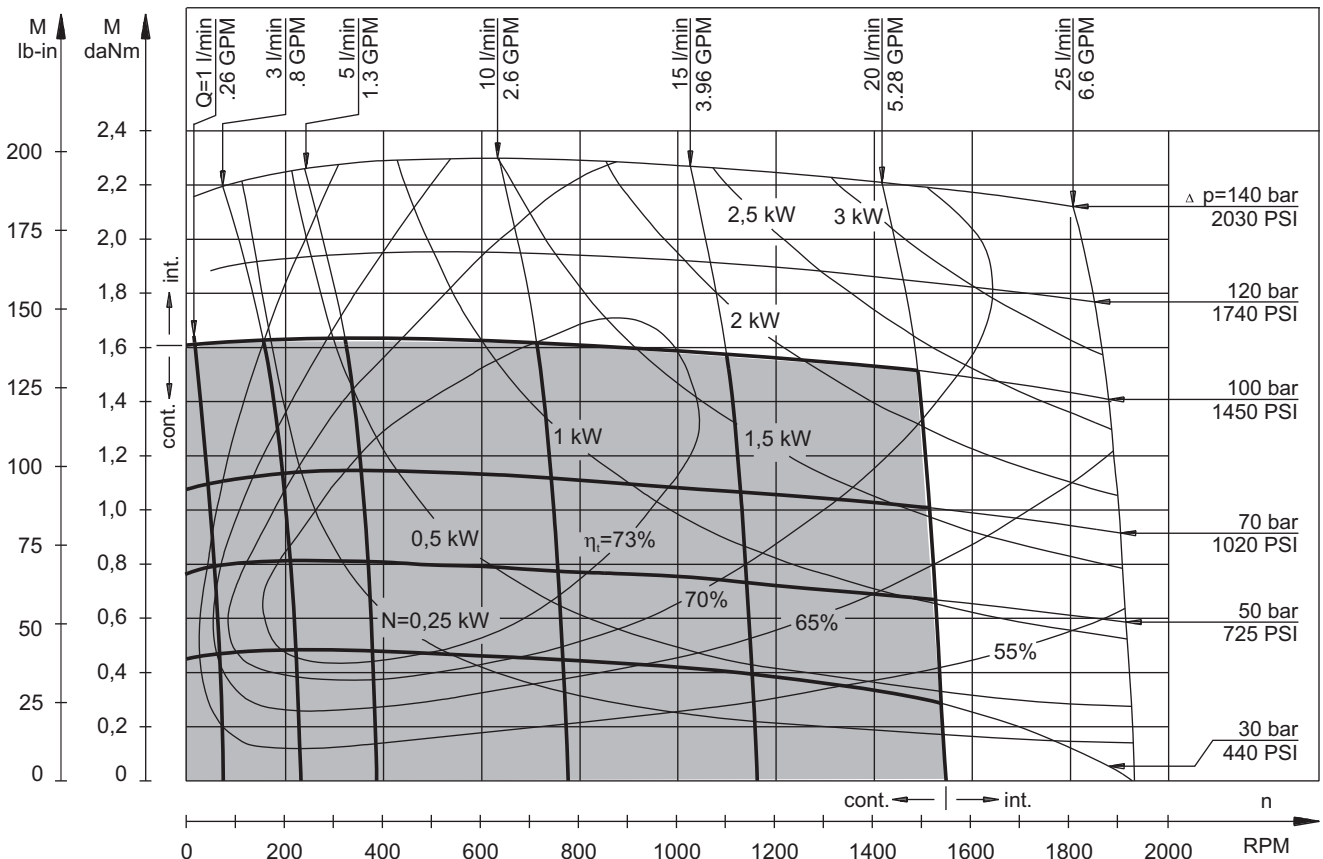

The function diagrams data is for average performance of randomly selected motors at back pressure 5÷10 bar [72.5÷145 PSI] and oil with viscosity of 32 mm²/s [150 SUS] at 50°C [122°F].

FUNCTION DIAGRAMS

MM 20

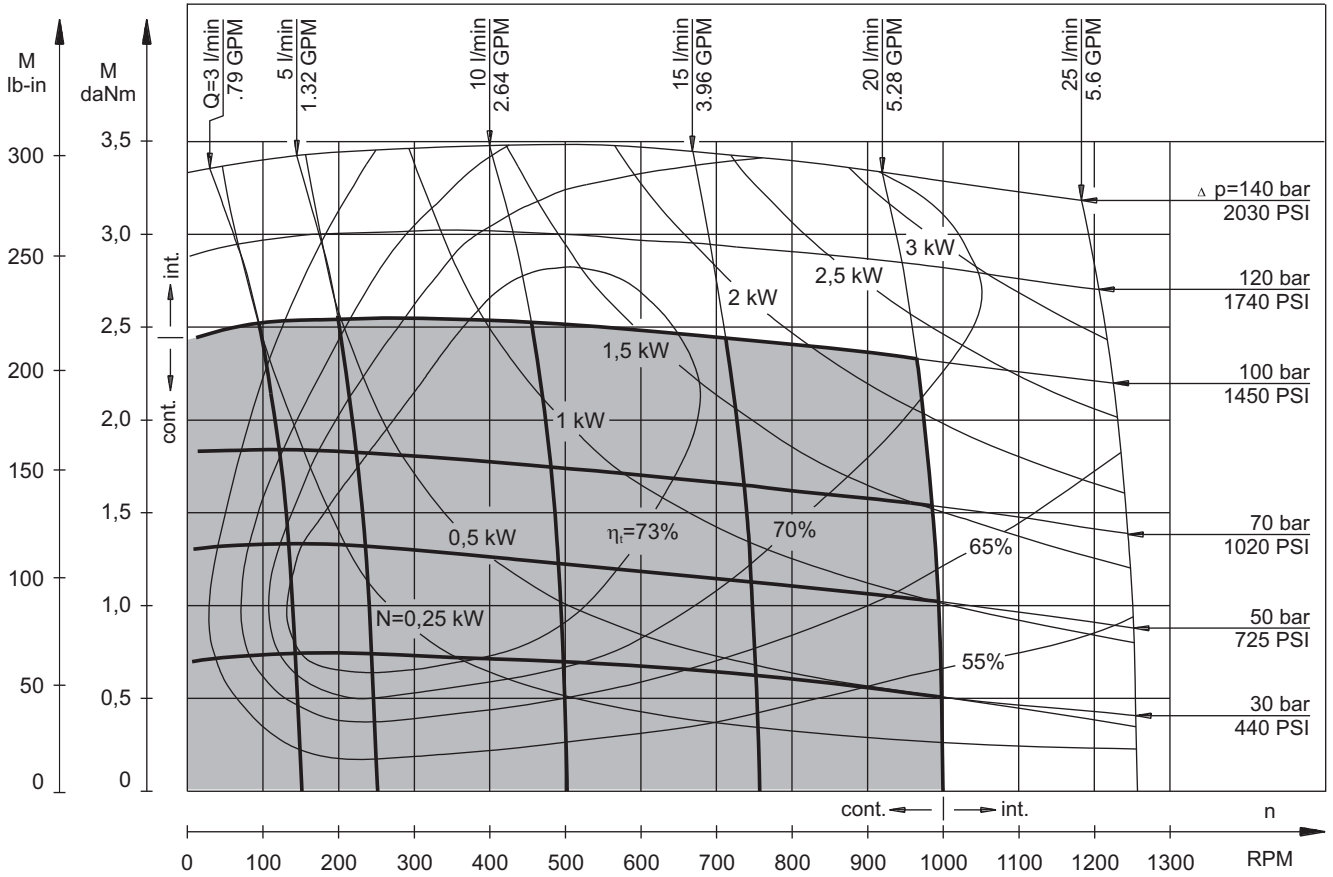

MM 32

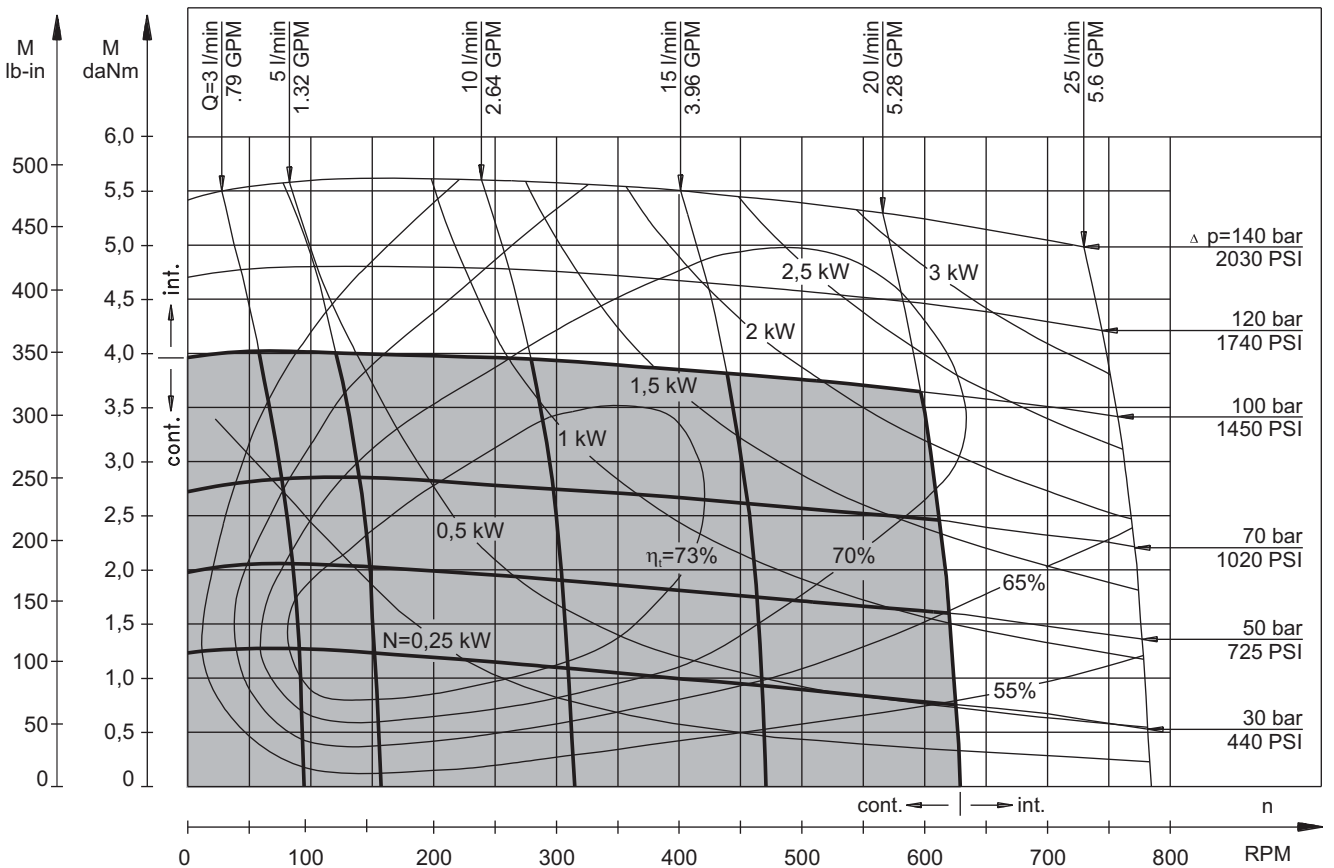

The function diagrams data is for average performance of randomly selected motors at back pressure 5÷10 bar [72.5÷145 PSI] and oil with viscosity of 32 mm²/s [150 SUS] at 50°C [122°F].

FUNCTION DIAGRAMS

MM 40

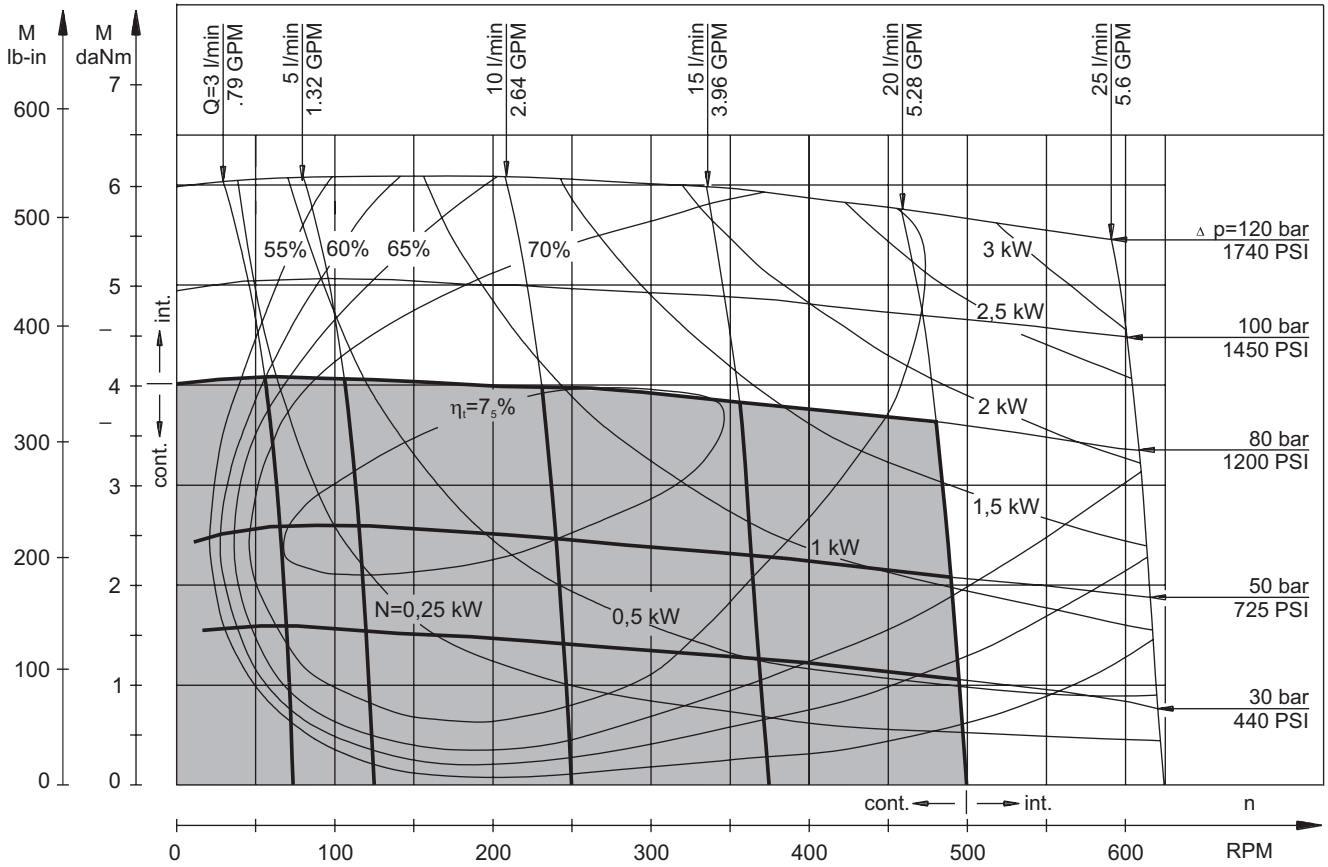

MM 50

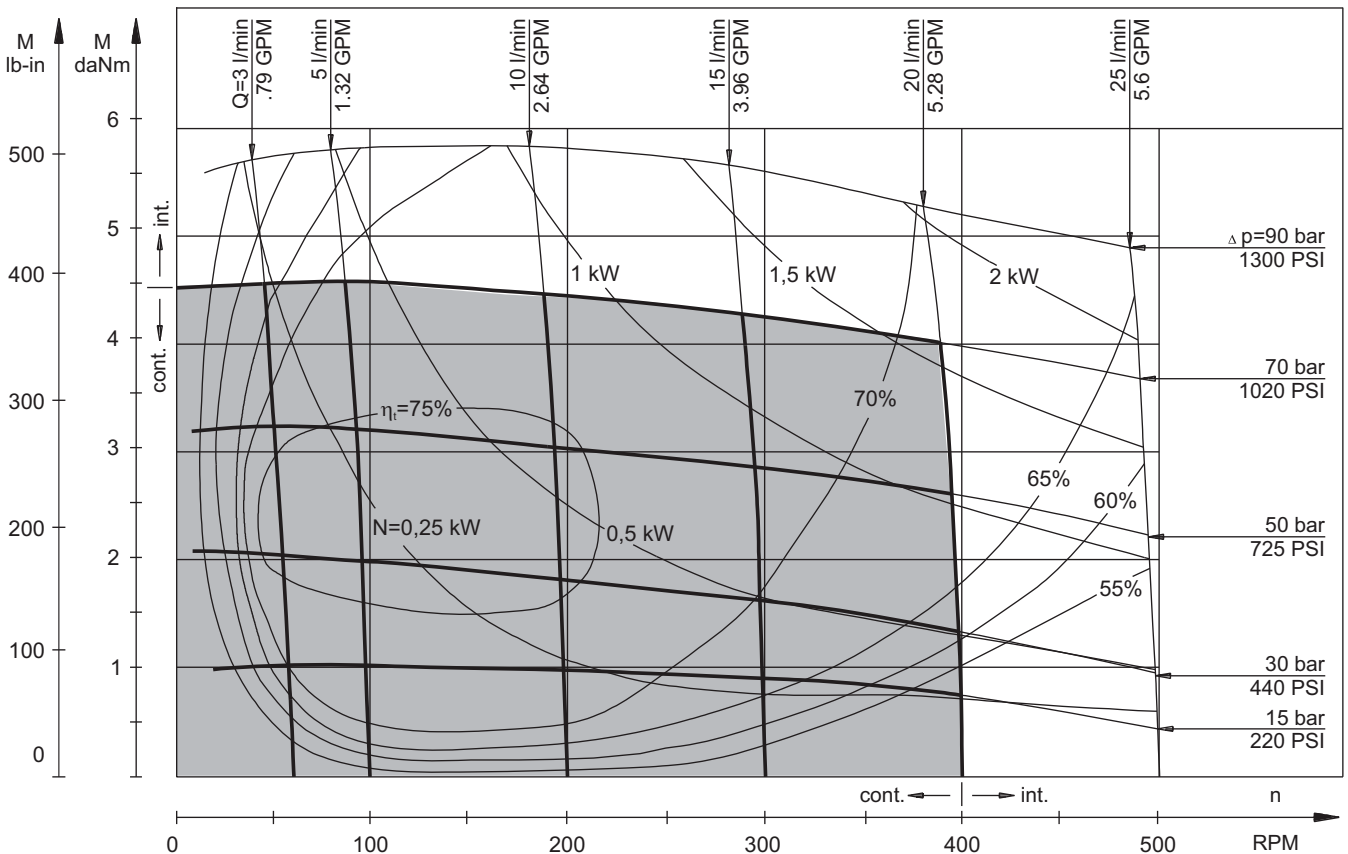

The function diagrams data is for average performance of randomly selected motors at back pressure 5÷10 bar [72.5÷145 PSI] and oil with viscosity of 32 mm²/s [150 SUS] at 50°C [122°F].

DIMENSIONS AND MOUNTING DATA
MM, MMS, MMP, MMD

Three Bolts Mount

SH Shaft C Shaft CK Shaft

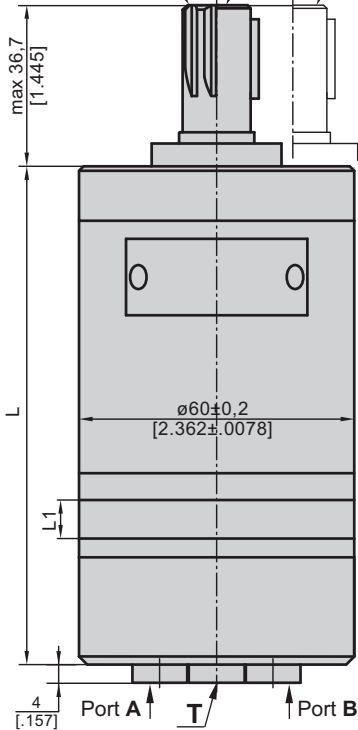

Rear Ports

Shaft Dim.
See Page 11

Flange Dim.
See Page 10

Port Dim.
See Page 10

F Oval Mount (2 Holes)

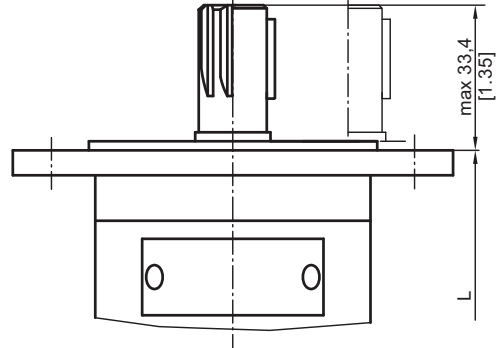

Standard Rotation

Viewed from Shaft End

Port A Pressurized - **CW**

Port B Pressurized - **CCW**

Reverse Rotation

Viewed from Shaft End

Port A Pressurized - **CCW**

Port B Pressurized - **CW**

S Side Ports

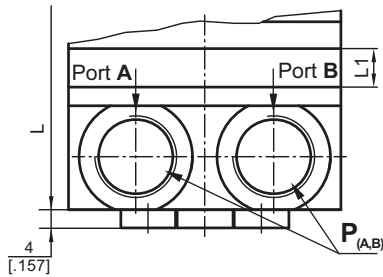

P Side Ports

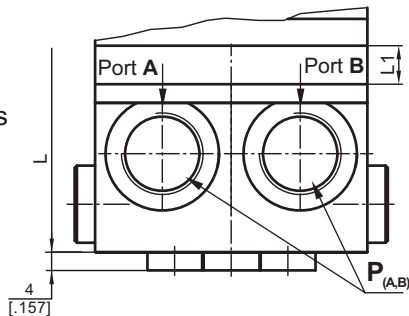

D Side Ports

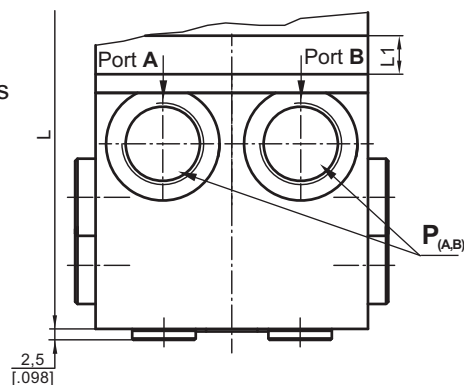

$P_{(A,B)}$: 2xG3/8 or 2xM18x1,5 - 12 mm [.47 in] depth

T : G1/8 or M10x1 - 10 mm [.39 in] depth

Type	L, mm [in]	Type	L, mm [in]	L _s , mm [in]
MM 8	104 [4.094]	MMS 8	105 [4.134]	3,5 [.138]
MM 12,5	106 [4.173]	MMS 12,5	107 [4.213]	5,5 [.217]
MM 20	109 [4.291]	MMS 20	110 [4.331]	8,5 [.335]
MM 32	114 [4.488]	MMS 32	115 [4.528]	13,5 [.531]
MM 40	117,5 [4.626]	MMS 40	118,5 [4.665]	17 [.669]
MM 50	121,5 [4.783]	MMS 50	122,5 [4.823]	21 [.827]

Type	L, mm [in]	Type	L, mm [in]	L _s , mm [in]
MMP 8	115 [4.528]	MMD 8	134 [5.276]	3,5 [.138]
MMP 12,5	117 [4.606]	MMD 12,5	136 [5.354]	5,5 [.217]
MMP 20	120 [4.724]	MMD 20	139 [5.472]	8,5 [.335]
MMP 32	125 [4.921]	MMD 32	144 [5.669]	13,5 [.531]
MMP 40	128,5 [5.039]	MMD 40	147,5 [5.807]	17 [.669]
MMP 50	132,5 [5.217]	MMD 50	151,5 [5.965]	21 [.827]

For "F" Flange +3,5 mm



MOUNTING

Three Bolts Mount

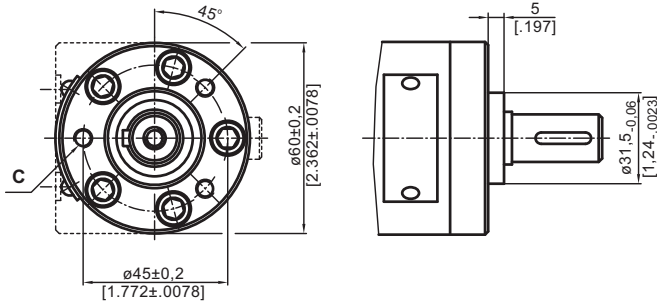

F Oval Mount (2 Holes)

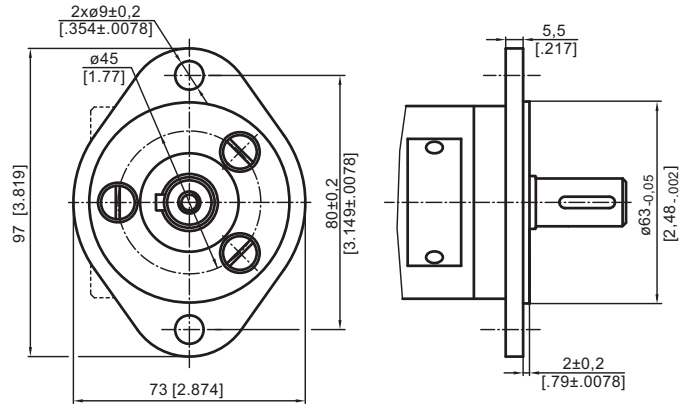

PORTS

Rear Ports

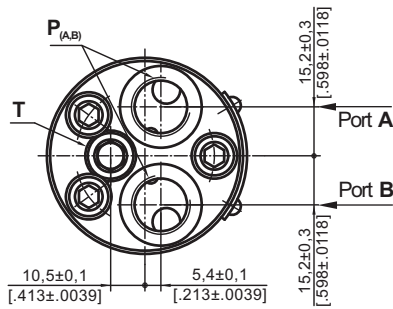

S Side Ports

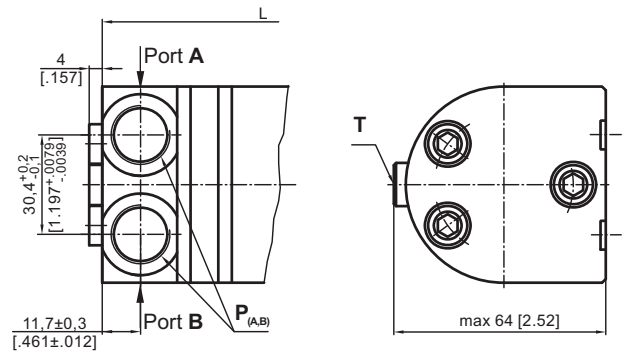

P Side Ports with Single Crossover Relief Valve

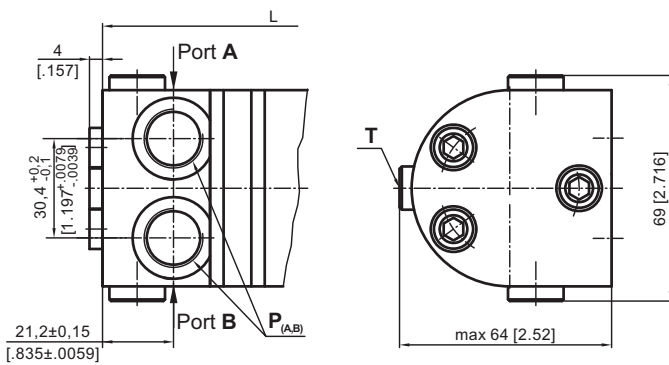

D Side Ports with Dual Crossover Relief Valve

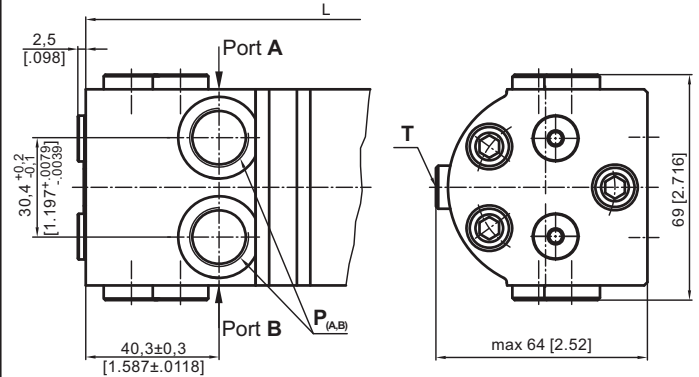

Standard Rotation
Viewed from Shaft End
Port A Pressurized - **CW**
Port B Pressurized - **CCW**

Reverse Rotation
Viewed from Shaft End
Port A Pressurized - **CCW**
Port B Pressurized - **CW**

C : 3xM6 - 12 mm [.47 in] depth
P_(A,B) : 2xG3/8 or 2xM18x1,5 - 12 mm [.47 in] depth
T : G1/8 or M10x1 - 10 mm [.39 in] depth

SHAFT EXTENSIONS

C - $\varnothing 16$ straight, Parallel key 5x5x16 DIN 6885
Max. Torque 3,9 daNm [345 lb-in]

CK - $\varnothing 14$ straight, Parallel key 5x5x16 DIN 6885
Max. Torque 3 daNm [265 lb-in]

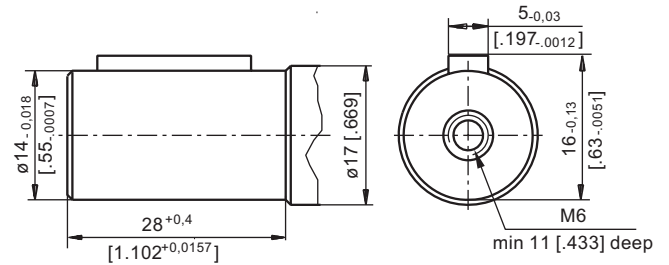
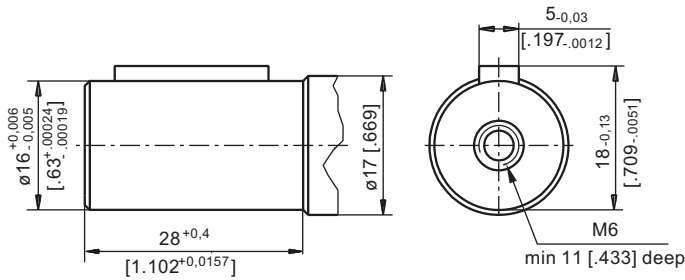

SH - $\varnothing 16,5$ Splined, B17x14 DIN 5482
Max. Torque 4,4 daNm [390 lb-in]

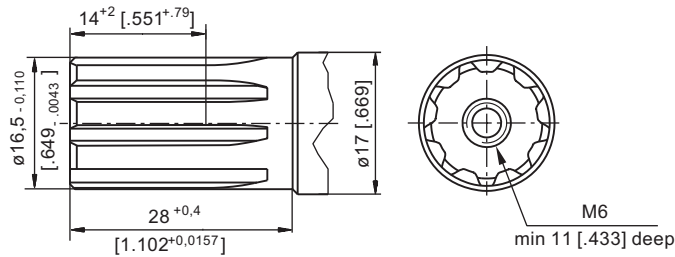

PERMISSIBLE SHAFT LOAD

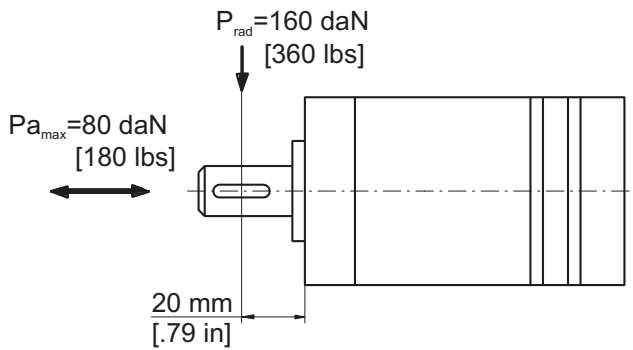

The permissible radial shaft load [Prad] is calculated from the distance [L] between the point of load application and the mounting surface:

$$P_{rad} = \frac{600}{n} \times \frac{13040}{61,5 + L}, \text{ [daN]}$$

[L in mm; L ≤ 80 mm]

$$P_{rad} = \frac{600}{n} \times \frac{1155}{2,42 + L}, \text{ [lbs]}$$

[L in inch; L ≤ 3.15 in]

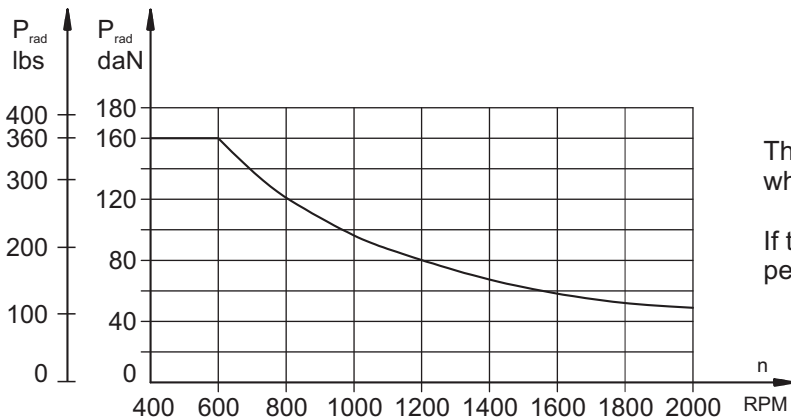

The drawing shows the permissible radial load when L=20 mm [.79 in].

If the calculated shaft load exceeds the permissible, a flexible coupling must be used.

ORDER CODE

	1	2	3	4	5	6	7	8	9	10
MM										

Pos.1 - Adjustment Option

omit - without valve

P* - Side ports with single crossover relief valve

D* - Side ports with dual crossover relief valve

Pos.2 - Mounting Flange

omit - Three bolts mount

F - Oval mount, two holes

Pos.3 - Port type (not valid for P and D version)

omit - Rear ports

S - Side ports

Pos.4 - Displacement code

8 - 8,2 cm³/rev [.5 in³/rev]

12.5 - 12,9 cm³/rev [.79 in³/rev]

20 - 20,0 cm³/rev [1.22 in³/rev]

32 - 31,8 cm³/rev [1.93 in³/rev]

40 - 40,0 cm³/rev [2.44 in³/rev]

50 - 50,0 cm³/rev [3.05 in³/rev]

Pos. 5 - Shaft Extensions*

C - ø16 straight, Parallel key A5x5x16 DIN6885

VC - ø16 straight, Parallel key A5x5x16 DIN6885
with corrosion resistant bushing

CK - ø14 straight, Parallel key 5x5x16 DIN6885

SH - ø16,5 splined, B17x14 DIN 5482

Pos. 6 - Ports

omit - BSPP (ISO 228)

M - Metric (ISO 262)

Pos. 7 - Line to control** (see page 4)

/L - B → A (left running)

/R - A → B (right running)

Pos. 8 - Valve Rated Pressure***

/50 - Δp=50 bar [725 PSI]

/80 - Δp=80 bar [1160 PSI]

/100 - Δp=100 bar [1450 PSI]

/140 - Δp=140 bar [2030 PSI]

Pos. 9 - Special Features (see page 120)

Pos.10 - Design Series

omit - Factory specified

NOTES:

* The permissible output torque for shafts must not be exceeded!

** For P option useful only.

*** For P and D option useful only.

MMP and **MMD** are available with new crossover relief valves with improved characteristics. The new valves allow easier pressure setting in a wider range: from 50 bar [725 PSI] to 140 bar [2030 PSI]. For more information about MMP and MMD - series 2 please contact with "M+S Hydraulic".

The Valve pressure setting must be at flow rate of 2 lpm [.53 GPM].

The hydraulic motors are mangano - phosphatized as standard.

F - FLANGE (2 Holes)

Order No for Flange:48443 014 00

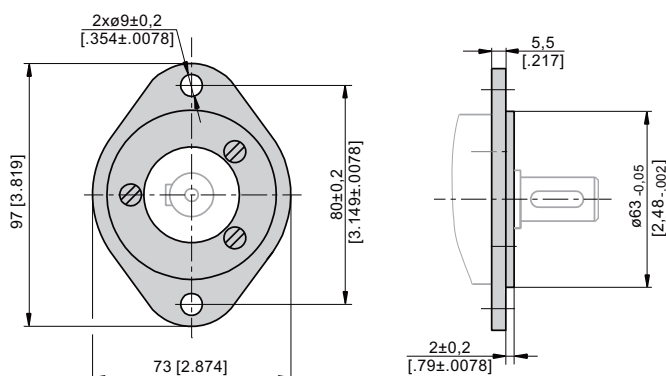

F Flange is mounted to the motor with 3 screws - M6x14. Tightening Torque: 5-6 Nm [44-53 lb-in].