

Lynkobling FAP-P

Lynkobling FAP-P

Standard tætninger / Standard seals NBR (Nitrile) / PUR (Polyurethane) / POM (Delrin)

Fra -20°C til 100°C / From -4°F to 212°F

ISO 7241-2

DIN 3852

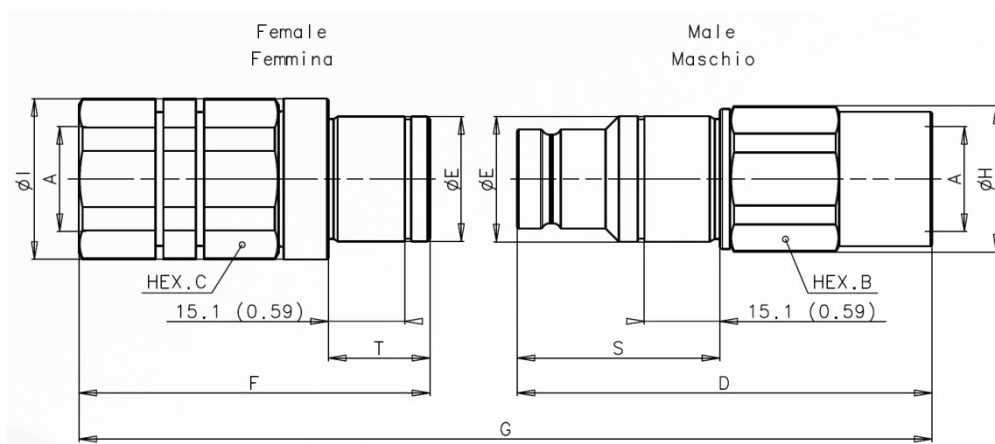

Hun / Female Varenummer	Han / Male Varenummer	Beskrivelse	A	Enhed	B	C	D	E	F	G	H	I	S	T	Vægt kg / lb	
															Female	Male
80500052	80500053	FAP 9PA 3/8 BSP	3/8"	mm inch	27 1,06	30 1,18	80 3,15	25 0,98	64,8 2,55	128,8 5,07	29 1,14	32 1,26	40,3 1,59	20,2 0,80	0,241 0,53	0,209 0,46
80500050	80500051	FAP 9PA 1/2 BSP	1/2"	mm inch	27 1,06	3,0 1,18	82,5 3,25	25 0,98	69,8 2,75	136,3 5,37	29 1,14	32 1,26	40,3 1,59	20,2 0,80	0,246 0,54	0,201 0,44
80500058	80500059	FAP 13P 3/4 BSP	3/4"	mm inch	36 1,42	36 1,42	39,4 3,68	32 1,26	83,7 3,30	159,9 6,30	38,5 1,52	40 1,57	45,4 1,79	20,4 0,80	0,428 0,94	0,400 0,88

Lynkobling FAP-P

Descrizione	Size	ISO Size	Portata nominale		Max. portata suggerita		Forza ° accoppiamento		Sezione di spinta idrostatica accoppiato	Spillamento*
			l/min	GPM	l/min	GPM	Nm	lbf		
	Inch	mm							Cm2	ml
FAP7	1/4	-	12	3,18	24	6,36	130	29,25	0,723	0,010
FAP9P	3/8	-	23	6,10	46	12,19	300	67,50	1,226	0,012
FAP13P	1/2	-	45	11,93	90	23,85	320	72,00	1,893	0,020
FAP15P	5/8	-	74	19,61	148	39,22	320	72,00	2,404	0,110
FAP17P	3/4	-	100	26,50	200	53,00	500	112,50	3,298	0,032
FAP21P	1	-	189	50,09	378	100,17	520	117,00	4,335	0,035

Descrizione	Max. pressione di esercizio						Pressione di scoppio					
	Accoppiato		Maschio		Femmina		Accoppiato		Maschio		Femmina	
	MPa	psi	MPa	psi	MPa	psi	MPa	psi	MPa	psi	MPa	psi
FAP7	42	6090	42	6090	42	6090	126	18270	126	18270	126	18270
FAP9P	35	5075	35	5075	35	5075	120	17400	120	17400	100	14500
FAP13P	33	4785	33	4785	33	4785	120	17400	120	17400	100	14500
FAP15P	33	4785	33	4785	33	4785	120	17400	120	17400	100	14500
FAP17P	33	4785	33	4785	33	4785	120	17400	120	17400	100	14500
FAP21P	30	4350	30	4350	30	4350	100	14500	100	14500	80	11600

Descrizione	Max. pressione residua durante accoppiamento						Max. pressione residua durante disaccoppiamento	
	Maschio		Femmina		Maschio e Femmina		MPa	psi
	Fem. a scarico	Mas. a scarico	Mas. a scarico	Fem. a scarico	Maschio e Femmina			
FAP7	30	4350	30	4350	25	3625	25	3625
FAP9P	25	3625	25	3625	25	3625	25	3625
FAP13P	25	3625	25	3625	20	2900	20	2900
FAP15P	25	3625	25	3625	20	2900	20	2900
FAP17P	25	3625	25	3625	15	2175	15	2175
FAP21P	25	3625	25	3625	15	2175	15	2175

Prove i overensstemmelse med ISO 7241-2

