

Product Tech News

Hydraulic motors type CMR

CMR... motors with high pressure seal and drain connection:

The shaft seal pressure equals the pressure in the drain line.

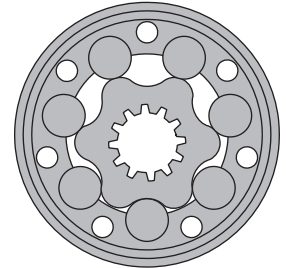
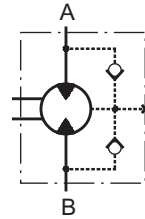
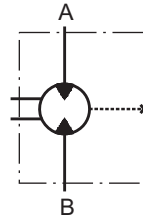

APPLICATION

- » Conveyors
- » Feeding mechanism of robots and manipulators
- » Metal working machines
- » Textile machines
- » Agriculture machines
- » Food industries
- » Grass cutting machinery etc.

OPTIONS

- » Model- Spool valve, roll-gerotor
- » Flange mount-oval mount, two holes
- » Side ports
- » Shaft: - $\varnothing 25$ straight, parallel key A8x7x32
 - $\varnothing 1$ " straight, Parallel key 1/4"x1/4"x1 1/4" Bs46
 - $\varnothing 1$ " splined BS 2059 (SAE 6B)
- » Port connection - G 1/2 ; Drain Port - G 1/4 - BSPP (ISO 288)
- » Pilot diameter - $\varnothing 82.5$
- » High pressure shaft seal
- » Suitable for medium and low duty

GENERAL

Max. Displacement,	cm ³ /rev	397
Max. Speed,	RPM	970
Max. Torque,	daNm	cont. 33,0 int. 42,5
Max. Output,	kW	14,0
Max. Pressure Drop,	bar	cont. 140 int. 165
Max. Oil Flow,	lpm	75
Min. Speed,	RPM	10
Pressure fluid	Mineral based- HLP(DIN 51524) or HM(ISO 6743/4)	
Temperature range,	°C	-40÷140
Optimal Viscosity range,	mm ² /s	20÷75
Filtration	ISO code 20/16 (Min. recommended fluid filtration of 25 micron)	

Oil flow in drain line

Pressure drop [bar]	Viscosity [mm ² /s]	Oil flow in drain line [lpm]
100	20	2,5
	35	1,8
140	20	3,5
	35	2,8

Pressure Losses

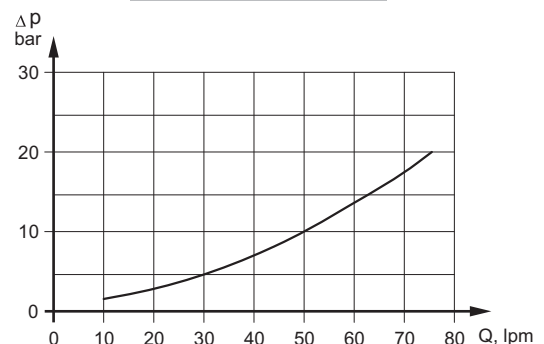

SPECIFICATION DATA

Type		CMR 50	CMR 80	CMR 100	CMR 125	CMR 160	CMR 200	CMR 250	CMR 315	CMR 400
Displacement, cm ³ /rev		51,5	80,3	99,8	125,7	159,6	199,8	250,1	315,7	397
Max. Speed, [RPM]	Cont.	776	747	601	477	375	300	240	190	151
	Int.*	970	933	750	596	470	375	300	237	188
Max. Torque, daNm	Cont.	10,0	15,7	19,5	24,5	31,0	29,0	31,5	33,0	33,0
	Int.*	11,4	17,7	22,0	27,7	35,2	34,7	41,8	40,1	42,5
	Peak**	12,3	19,0	23,5	30,0	38,5	38,5	42,5	50,1	50,0
Max. Output, kW	Cont.	6,5	10,0	10,0	10,0	10,0	7,5	6,5	5,3	4,2
	Int.*	9,0	14,0	13,2	13,0	13,0	10,3	10,0	7,0	6,2
Max. Pressure Drop, bar	Cont.	140	140	140	140	140	105	90	75	60
	Int.*	165	165	165	165	165	130	125	95	80
	Peak**	185	185	185	185	185	150	140	130	100
Max. Inlet Pressure, bar	Cont.	165	165	165	165	165	165	165	165	165
	Int.*	185	185	185	185	185	185	185	185	185
	Peak**	200	200	200	200	200	200	200	200	200
Max. Oil Flow, lpm	Cont.	40	60	60	60	60	60	60	60	60
	Int.*	50	75	75	75	75	75	75	75	75
Max. Return Pressure with Drain Line, bar	Cont.	165	165	165	165	165	165	165	165	165
	Int.*	185	185	185	185	185	185	185	185	185
	Peak**	200	200	200	200	200	200	200	200	200
Max. Starting Pressure with Unloaded Shaft, bar		10	10	10	10	10	7	7	7	6
Min. Starting Torque, daNm		8,1	12,6	15,6	19,7	25,0	24,6	25,2	26,5	26,7
Min. Speed***, RPM		10	10	10	10	10	10	10	10	10

* Intermittent operation: the permissible values may occur for max. 10% of every minute.

** Peak load: the permissible values may occur for max. 1% of every minute.

*** For speeds lower than given, consult factory or your regional manager.

- Intermittent speed and intermittent pressure drop must not occur simultaneously.
- Recommended filtration is per ISO cleanliness code 20/16. A nominal filtration of 25 micron or better.
- Recommend using a premium quality, anti-wear type mineral based hydraulic oil HLP(DIN51524) or HM (ISO 6743/4).
If using synthetic fluids consult the factory for alternative seal materials.
- Recommended minimum oil viscosity 70 SUS [13 mm²/s] at 122°F [50°C].
- Recommended maximum system operating temperature is 180°F [82°C].
- To assure optimum motor life fill with fluid prior to loading and run at moderate load and speed for 10-15 minutes.

DIMENSIONS AND MOUNTING DATA

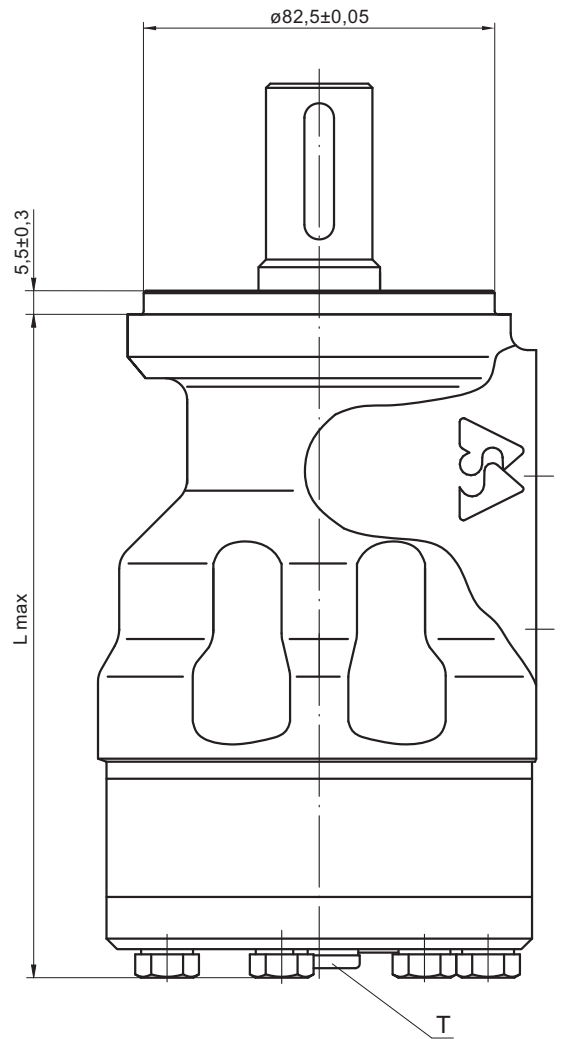
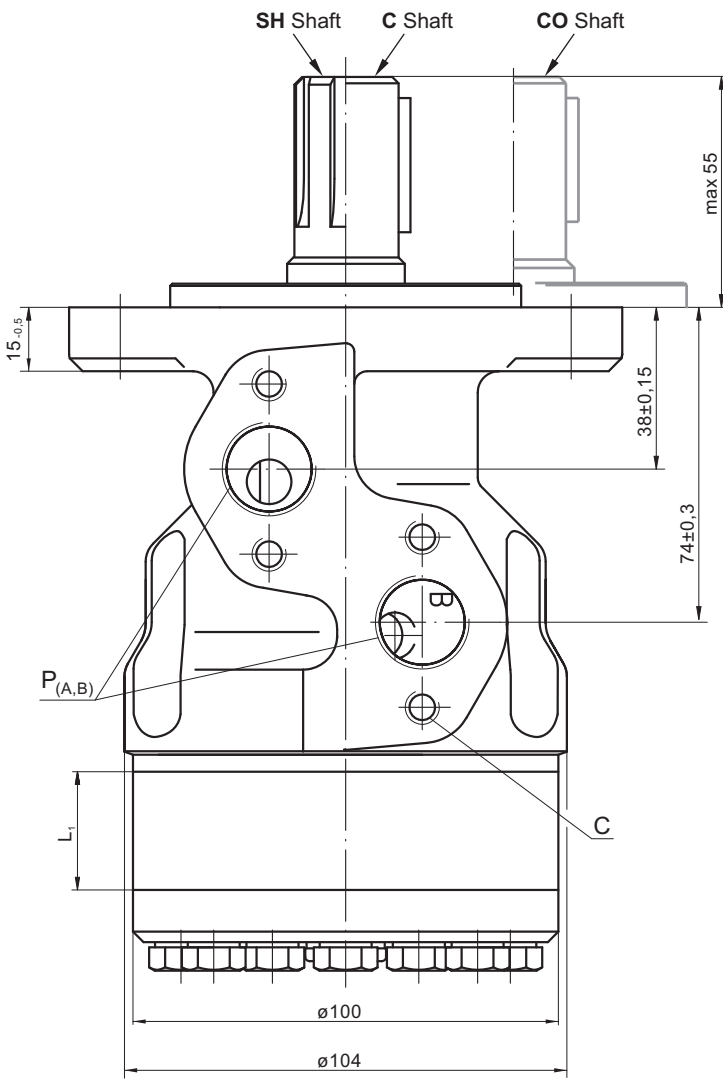

- C** : 4xM8 - 13 mm depth
- P_(A,B)** : 2xG1/2 - 16 mm depth
- T** : G1/4 - 12 mm depth (plugged)

Standard Rotation
Viewed from Shaft End
Port **A** Pressurized - **CW**
Port **B** Pressurized - **CCW**

Reverse Rotation
Viewed from Shaft End
Port **A** Pressurized - **CCW**
Port **B** Pressurized - **CW**

Type	L _{max} , mm	L ₁ , mm
CMR 50	138,0	9,0
CMR 80	143,0	14,0
CMR 100	146,0	17,4
CMR 125	150,5	21,8
CMR 160	156,5	27,8
CMR 200	163,5	34,8
CMR 250	172,0	43,5
CMR 315	183,0	54,8
CMR 400	198,0	69,4

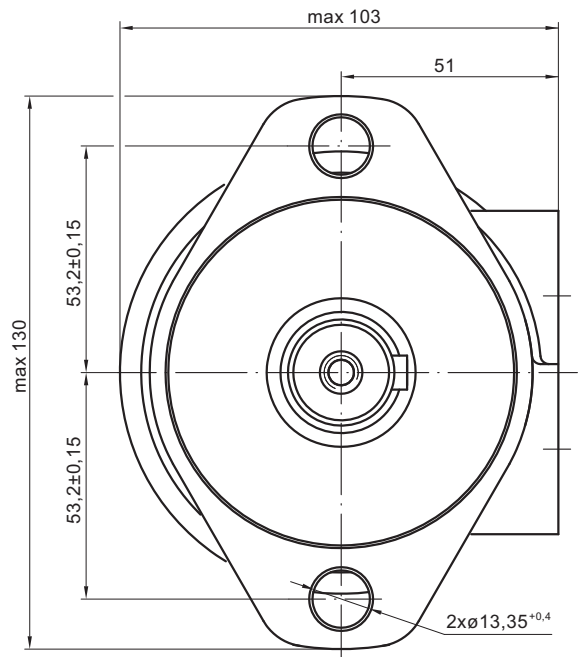

SHAFT EXTENSIONS

C - $\phi 25$ straight, Parallel key A8x7x32 DIN 6885
Max. Torque 34 daNm

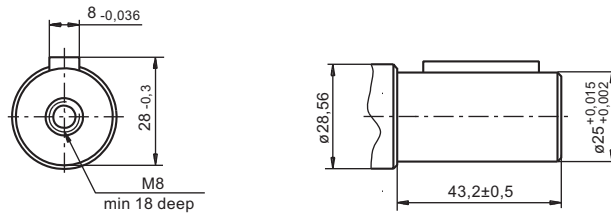

CO - $\phi 1$ " straight, Parallel key $\frac{1}{4}$ "x $\frac{1}{4}$ "x $\frac{1}{4}$ " BS46
Max. Torque 34 daNm

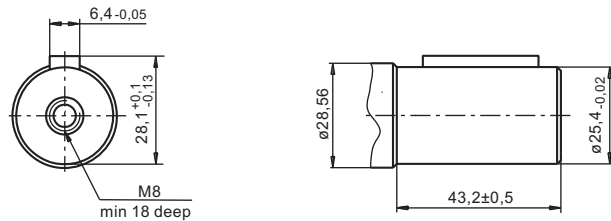

SH - splined, BS 2059 (SAE 6B)
Max. Torque 40 daNm

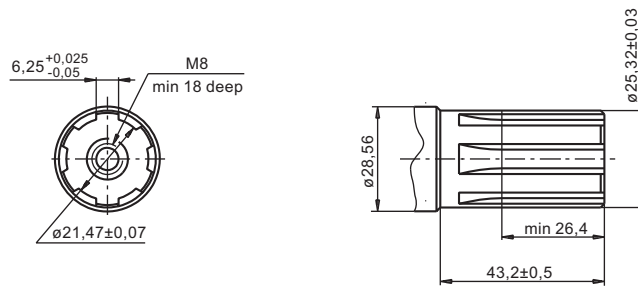

PORTS

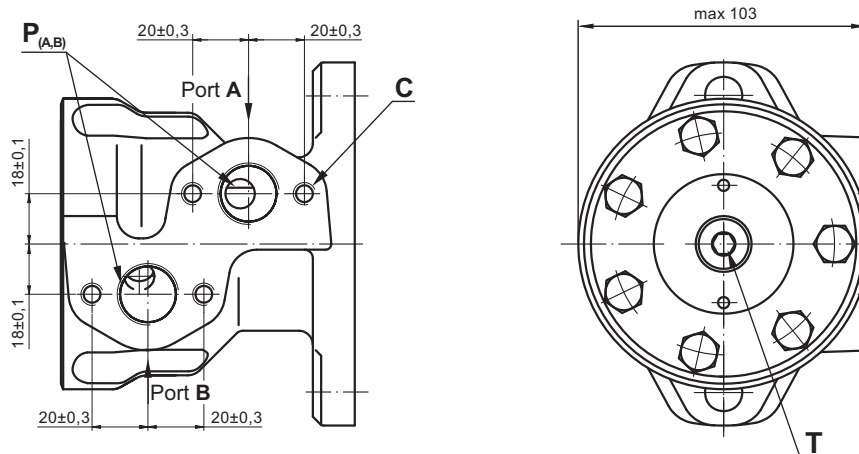

- C** : 4xM8 - 13 mm depth
- P_(A,B)** : 2xG1/2 - 16 mm depth
- T** : G1/4 - 12 mm depth (plugged)

Standard Rotation
Viewed from Shaft End
Port **A** Pressurized - **CW**
Port **B** Pressurized - **CCW**

Reverse Rotation
Viewed from Shaft End
Port **A** Pressurized - **CCW**
Port **B** Pressurized - **CW**

PERMISSIBLE SHAFT LOADS FOR CMR MOTORS

The permissible radial shaft load P_{rad} depends on the speed RPM and distance L from the point of load to the mounting flange.

$$\text{Radial Shaft Load } P_{rad} = \frac{800}{\text{RPM}} \times \frac{15000}{95+L}, \text{ daN}^*$$

RPM > 200 min⁻¹
L < 55 mm

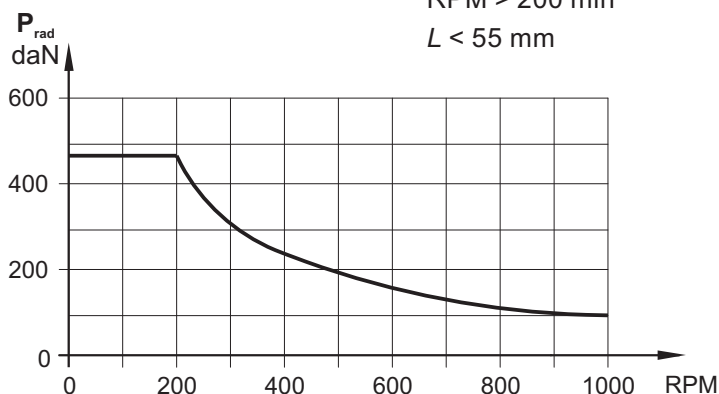

$P_{a\max} = 150 \text{ daN}$

$P_{a\max} = 200 \text{ daN}$

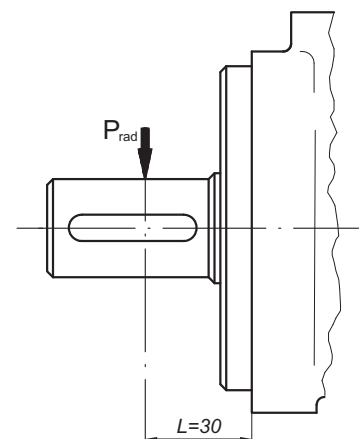

MAX. PERMISSIBLE SHAFT SEAL PRESSURE

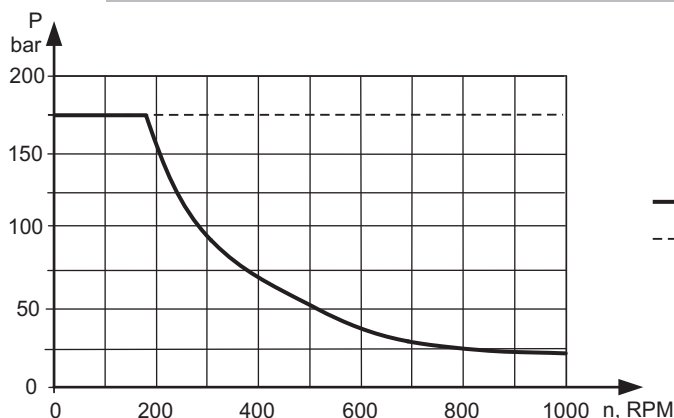

— - continuous operations

- - - - - intermittent operations

ORDER CODE

	1	2	3	4	5
CMR					

Pos.1 - Displacement code

50	- 51,5 cm ³ /rev
80	- 80,3 cm ³ /rev
100	- 99,8 cm ³ /rev
125	- 125,7 cm ³ /rev
160	- 159,6 cm ³ /rev
200	- 199,8 cm ³ /rev
250	- 250,1 cm ³ /rev
315	- 315,7 cm ³ /rev
400	- 397,0 cm ³ /rev

Pos.2 - Shaft Extensions*

C	- ø25 straight, Parallel key A 8x7x32 DIN 6885
CO	- ø1" straight, Parallel key 1/4"x1/4"x1 1/4" BS46
SH	- ø1" splined BS 2059 (SAE 6B)

Pos.3 - Option (Check Valves)

omit	- without check valves
K	- with check valves

Pos.4 - Option (Paint)**

omit	- no Paint
P	- Painted
PC	- Corrosion Protected Paint
PS	- Special Paint***
PCS	- Special Paint***

Pos.5 - Design Series

omit - Factory specified

- Notes:** * The permissible output torque for shafts must not be exceeded!
 ** Colour at customer's request.
 *** Non painted feeding surfaces, colour at customer's request.



68, Kozloduy St., 6100 Kazanlak, Bulgaria
 Tel.: ++359 431 65167
 Fax: +359 431 64114
 E-Mail: msh@ms-hydraulic.com