

PRESSURE REDUCING VALVES

AM3-RO-*

60 l/min - 32 MPa (320 bar)

1 DESCRIPTION

Stackable pressure reducing valve direct operated. The valve is made with a steel body combined with a pressure relief valve integrated in the body. The body of the valve is phosphate coated. The cartridge valve is zinc coated.

The pressure can be set in different pressure ranges.

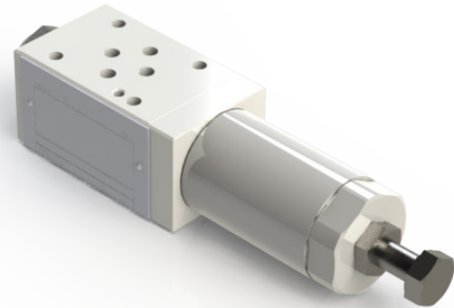

2 ORDERING CODE

(1)	(2)	(3)	(4)	(5)	(6)
AM3	- RO	-	/	-	/ 10

(1) AM3: stackable valve CETOP 03 - Pressure 32 MPa (320 bar)

(2) RO: pressure reducing, direct operated- 3 way valve

(3) Service lines where the controls operate:

P: control on P with 3^a way and drain to T line

A: control on A with 3^a way and drain to T line

B: control on B with 3^a way and drain to T line

(4) Pressure adjustment ranges:

3,2 : from 0,3 to 3,5 MPa (from 3 to 35 bar)

6,3: from 1 to 7 MPa (from 10 to 70 bar)

12,5: from 3 to 14 MPa (from 30 to 140 bar)

25: from 6 to 28 MPa (from 60 to 280 bar)

(5) Code reserved for more options and variants

M= adjustment hand knob

(6) Design number (progressive) of the valves

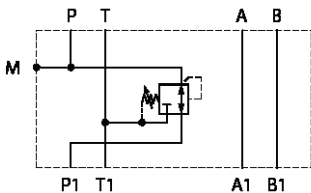
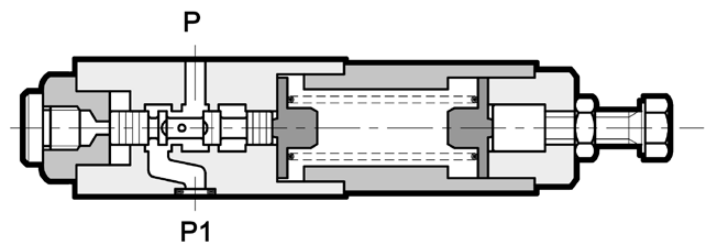
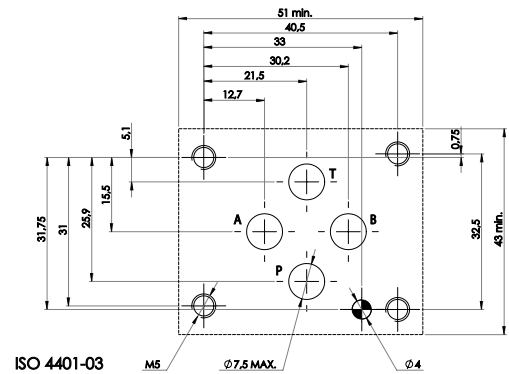

AM3-RO-P

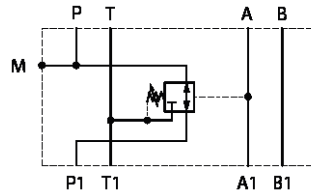

AM3-RO-A

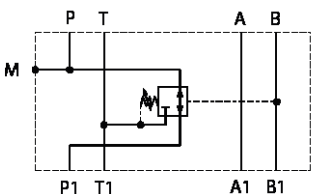

AM3-RO-B

All valves AM3-RO-* are 3 way, direct operated: If the pressure in the regulated chamber overcomes the value of the adjusted, reduced pressure, the valve discharges to T (at pressure value higher than the reduced pressure- see diagrams) thus acting as safety or relief valve.

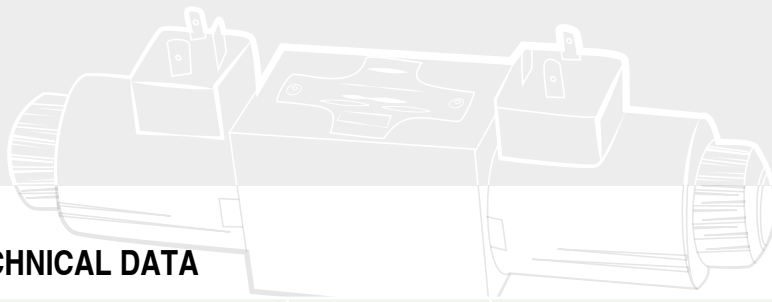

3 TECHNICAL DATA

Maximum rec. flow rate on free lines	1 d m ³ /s (60 l/min)	Adjustment of the relief pressure: Reduced pressure is obtained by throttling the flow on spool which is balanced, on one side, by the reduced pressure and, on the other side by the positioning spring. The value of the reduced pressure is changed by changing the compression of spring. To increase the value of the reduced pressure, turn clockwise the handknob or screw 3 by acting on ex. CH17 mm, after having unlocked ist nut. when the required level of pressure is reached, lock the nut.
on controlled lines	0,66 dn ³ /s (40 l/min)	
Maximum nominal pressure	32 MPa (320 bar)	For each pressure adjustment range, the pressure gradient is approx: 3,2: 0,7 MPa/turn (7 bar/turn) 6,3: 1,4 MPa/turn (14 bar/turn) 12,5: 2,5 MPa/turn (25 bar/turn) 25: 5 MPa/turn (50 bar/turn)
Maximum pressure on T	10 MPa (100 bar)	
Max drain	<1,2 cm ³ /s (0,07 l/min)	
Pressure curves	see 4	
Installation and dimensions	see 5	
Masses		
AM3-MP-BA	approx 2,3 kg	

4 TYPICAL DIAGRAMS

Typical curves for valves AM3-RO in standard configuration, with mineral oil at 36 cSt and at 50°C

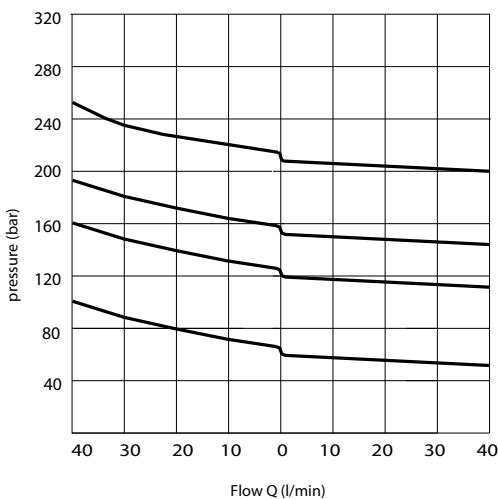

5 INSTALLATION DIMENSIONS (mm)

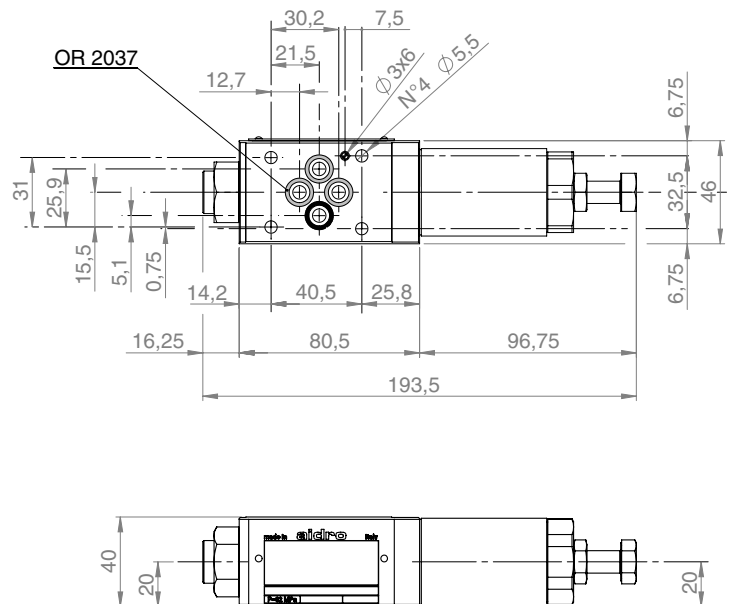

6 HYDRAULIC FLUIDS

Seals and materials used on standard valves AM3-* are fully coMPatible with hydraulic fluids of mineral oil base, upgraded with antifoaming and antioxidantizing agents. The hydraulic fluid must be kept clean and filtered to ISO 406 class 19/17/14, or better, and used in a recom ended viscosity range from 10 cSt to 60 cSt.

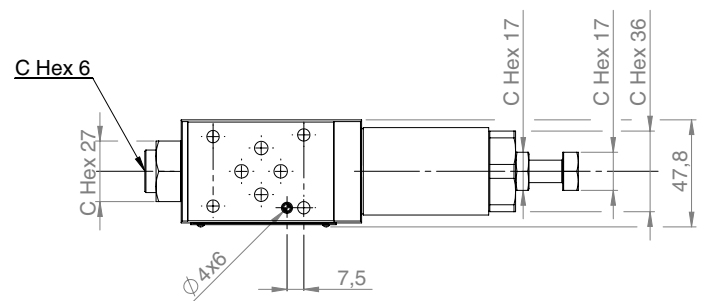

All stackable valves AM3-RO-* conform with ISO and CETOP specifications for mounting surface dimensions and for valves height 40 mm. Leakage between valve and mounting surface is prevented by the positive compression on their seats of 4 seals type OR 2037.