

## 1620 TEST POINT ADAPTORS

## Metric DKO 1620 Male/Female Tee Adaptors

For solder free screw-in pipe connections according to DIN 2353

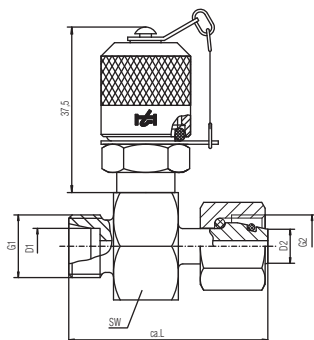

Series	p max Bar	G1 mm	D1 mm	G2 mm	D2 mm	SW mm	L mm	Part number
L 6	315	M 12 x 1.5	6	M 12 x 1.5	6	24	44.5	2103-KL-06.00
L 8	315	M 14 x 1.5	8	M 14 x 1.5	8	24	44.5	2103-KL-08.00
L 10	315	M 16 x 1.5	10	M 16 x 1.5	10	24	47.5	2103-KL-10.00
L 12	315	M 18 x 1.5	12	M 18 x 1.5	12	24	48.5	2103-KL-12.00
L 15	315	M 22 x 1.5	15	M 22 x 1.5	15	30	51.5	2103-KL-15.00
L 18	315	M 26 x 1.5	18	M 26 x 1.5	18	32	55.5	2103-KL-18.00
L 22	160	M 30 x 2	22	M 30 x 2	22	36	58.5	2103-KL-22.00
L 28	160	M 36 x 2	28	M 36 x 2	28	41	59	2103-KL-28.00
L 35	160	M 45 x 2	35	M 45 x 2	35	46	68	2103-KL-35.00
L 42	160	M 52 x 2	42	M 52 x 2	42	55	68	2103-KL-42.00
<hr/>								
S 6	630	M 14 x 1.5	6	M 14 x 1.5	6	24	46.5	2103-KS-06.00
S 8	630	M 16 x 1.5	8	M 16 x 1.5	8	24	48.5	2103-KS-08.00
S 10	630	M 18 x 1.5	10	M 18 x 1.5	10	24	49.5	2103-KS-10.00
S 12	630	M 20 x 1.5	12	M 20 x 1.5	12	24	50	2103-KS-12.00
S 14	630	M 22 x 1.5	14	M 22 x 1.5	14	27	53.5	2103-KS-14.00
S 16	400	M 24 x 1.5	16	M 24 x 1.5	16	30	56.5	2103-KS-16.00
S 20	400	M 30 x 2	20	M 30 x 2	20	36	64.5	2103-KS-20.00
S 25	400	M 36 x 2	25	M 36 x 2	25	41	66	2103-KS-25.00

## Minimess test thread adaptors

Adaptor for connection or change-over to various series such as 1620, 1615, 1215

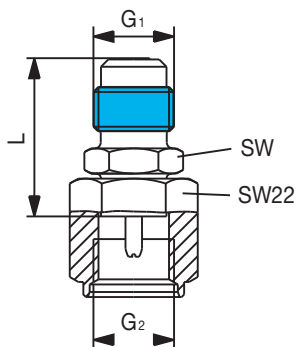

Thread G1	Thread G2	L mm	SW mm	Part number
M 12 x 1.5	M 16 x 2	25.2	17	2103-07-42.62
M 16 x 2	M 12 x 1.5	32	17	2101-07-44.62
M 16 x 1.5	M 16 x 2	31.4	17	2103-07-43.62
M 16 x 2	M 16 x 1.5	31.4	17	2102-07-44.62