

## PROPORTIONAL 4-WAY CONTROL VALVES SOLENOID OPERATED – CETOP 02 TYPE HD2 - PS - \*

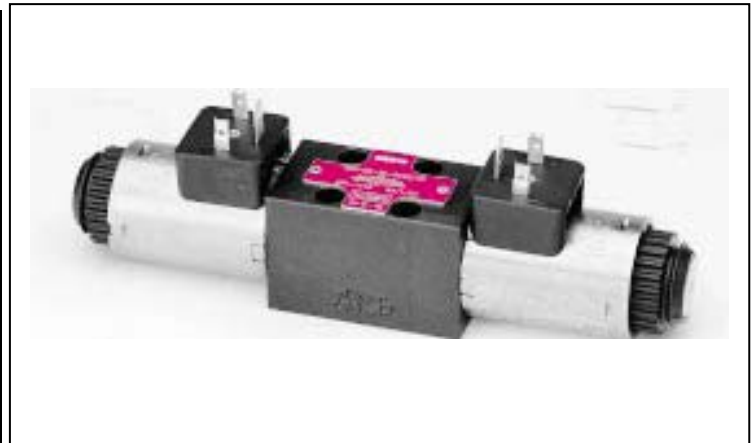

### 2 FUNCTIONAL SYMBOLS

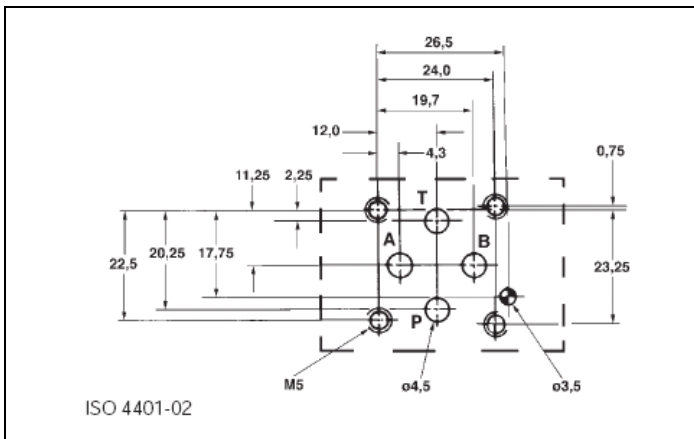
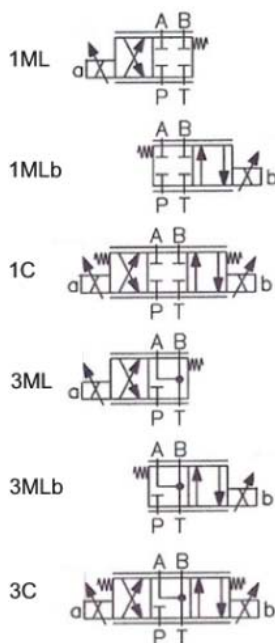

### 1 HOW TO READ THE MODEL CODE FOR VALVES HD3 – PS - \*

**HD2 - PS - (1) (P) - (C) - \*\* - (R2) / 10**  
 ① ② ③ ④ ⑤ ⑥ ⑦ ⑧

- ① HD2 : 4-way directional valve Cetop 02 – Pressure 32 Mpa (320 bar)
- ② PS : Proportional electric control
- ③ (1) : Functional spool type (see 2 7)
  - 1 : closed center (P, A, B, T blocked)
  - 3 : P blocked, A, B, T connected
- ④ (P) : Spool nominal flow – see 4
  - P : 12 l/min with  $\Delta P = 1$  Mpa (10 bar) (PA+BT or PB+AT)
  - R : 8 l/min with  $\Delta P = 1$  Mpa (10 bar) (PA+BT or PB+AT)
  - 04 : 04 l/min with  $\Delta P = 1$  Mpa (10 bar) (PA+BT or PB+AT)
  - D : differential  $Q_b = 2Q_a$ : 8/4 l/min with  $\Delta P = 1$  Mpa (10 bar)
- ⑤ (C) : Solenoid(s) and springs arrangements – see 7
  - C : 2 sol., spool is springs centred
  - ML : 1 sol. (“a”) spool is centred + 1 end position
  - MLb : 1 sol. (“b”) spool is centred + 1 end position
- ⑥ \*\* : Options and variants:
  - K : extended manual overrides – see 9
  - AK : extended manual overrides with air bleeding valves– see 9
  - ZC : zinc plated valves – see 13
- ⑦ (R2) : Type of coil(s) and supply voltages – see 6 14
  - R2 : R= 5  $\Omega$  standard for V12DC;
  - R4 : R=21  $\Omega$  standard for V24DC;
- ⑧ 10 : Design number (progressive) of the valve.

### 3 DESCRIPTION

The spool ⑫ shifts in to the valves body ⑪ subject to the action of springs ⑬ and proportional solenoid ①.

Spool ⑫, depending from its shape and its position in the valves body ⑪, opens and/or closes passages between P, A, B, T ports, thus controlling the direction and the rate of the hydraulic flow. Solenoid ① is energized by electric current flowing-in through cables; in case of electric cut-offs, the spool can be manually shifted by acting on the emergency pins ⑤, located at the end of the solenoids and accessible through the retaining nuts ⑩.

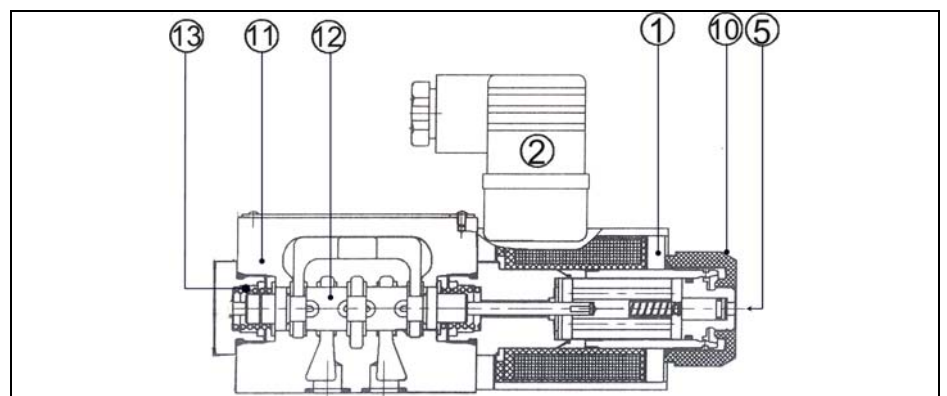

### 4 TYPICAL DIAGRAMS

Typical flow curves of valves HD2 – PS - \*, with spools type P, R, 04 – see 1, in standard configuration measured with mineral oil at 36 cSt and at 50°C at  $\Delta P=01$  Mpa (10 bar) for flow P → B A → T

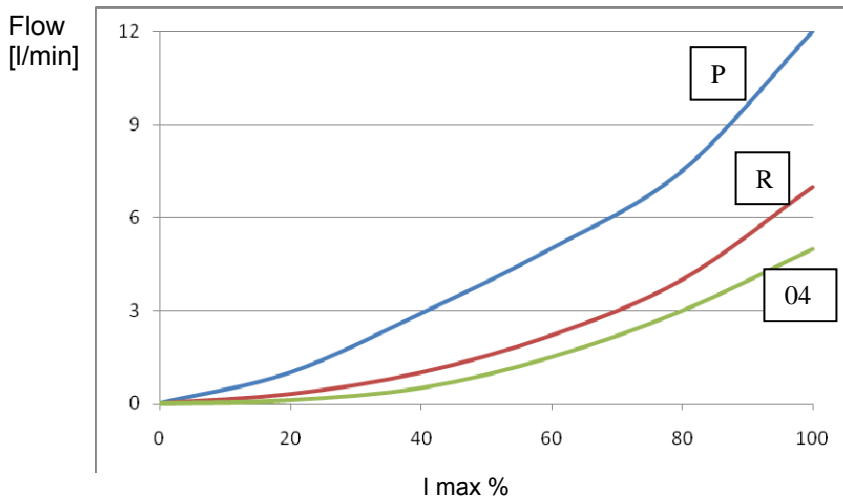

### 5 TECHNICAL DATA

Nominal flow rates	4, 8, 12 l/min – see 1
Maximum nominal pressure (P,A,B)	32 Mpa (320 bar)
Maximum pressure at T port	16 Mpa (160 bar)
Maximum rec. Pressure drops	10 Mpa (100 bar) see 8
Electric characteristics	See 6
Protection	DIN 40050 IP 67
Duty cycle	100%
Service life	$\geq 10^7$ cycles
Dimensions	See 10
Installation	See 11 14
Mass	Approx 1,0 / 1,4 kg.

### 6 ELECTRIC CHARACTERISTICS

Valves type HD2-PS-\* are operated by proportional solenoids.

The values of nominal max. current are:

for coils type R2 ( 5  $\Omega$ ): I max = 1,7 A

R4 (21  $\Omega$ ): I max = 0,8 A

Currents to hydraulic proportional valves are normally supplied by an electronic driver based on PWM mode of operation, capable of full control of min and max values of current for drivers type UED-M15 – see 14.

### 8 FLOW RATES AND PRESSURE DIFFERENTIAL

For a given  $\Delta P$  on a given valve the flow rates are proportional to the driving current (see 4); for a given driving current on a given valve, the flow rates increase with the increasing of the  $\Delta P$  up to certain limits. Typical limit curves are:

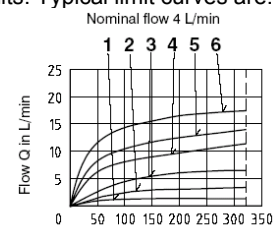

Solenoid current:

- 1 = 50%
- 2 = 60%
- 3 = 70%
- 4 = 80%
- 5 = 90%
- 6 = 100%

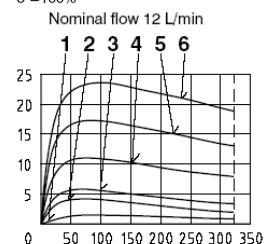

Input pressure  $p_0$  in bar

### 7 SPOOL IDENTIFICATION AND NOMINAL FLOW RATES

#### Nominal flow rate 4 l/min

	HD2-PS-104ML-R*		HD2-PS-304ML-R*
	HD2-PS-104MLb-R*		HD2-PS-304MLb-R*
	HD2-PS-104C-R*		HD2-PS-304C-R*

#### Nominal flow rate 8 l/min

	HD2-PS-1RML-R*		HD2-PS-3RML-R*
	HD2-PS-1RMLb-R*		HD2-PS-3RMLb-R*
	HD2-PS-1RC-R*		HD2-PS-3RC-R*

#### Nominal flow rate 12 l/min

	HD2-PS-1PML-R*		HD2-PS-3PML-R*
	HD2-PS-1PMLb-R*		HD2-PS-3PMLb-R*
	HD2-PS-1PC-R*		HD2-PS-3PC-R*

Differential flow :  $Q_b = 2Q_a$  (example P → B=8 l/min and A → T=4 l/min)

	HD2-PS-1DC-R*		HD2-PS-3DC-R*
--	---------------	--	---------------

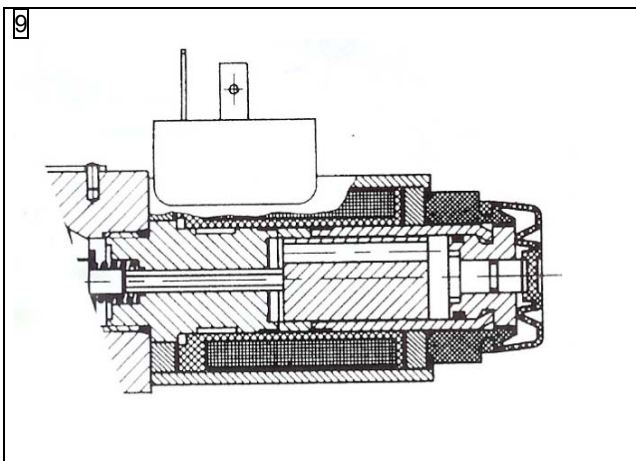

9

### VERSION "K": EXTENDED EMERGENCY PIN

Solenoid valves according to "K" version have extended emergency actuator pins protruding from the solenoid shape, that permit a quick and easy "Hand operation" of the valves, without the need of any tool.

The actuator pin and the end of the solenoid are protected by a flexible rubber cap that makes easy operation and protects from moisture and water splashes.

### VERSION "AK": EXTENDED PIN AND AIR VALVES.

Proportional valves according to "AK" version have extended emergency actuator pins that incorporate air bleeding valves, to purge air from the solenoid tube for a simplified start-up of the system.

The actuator pin and the end of the solenoid are protected by a flexible rubber cap that makes easy operation and protects from moisture and water splashes.

## 10 INSTALLATION DIMENSIONS

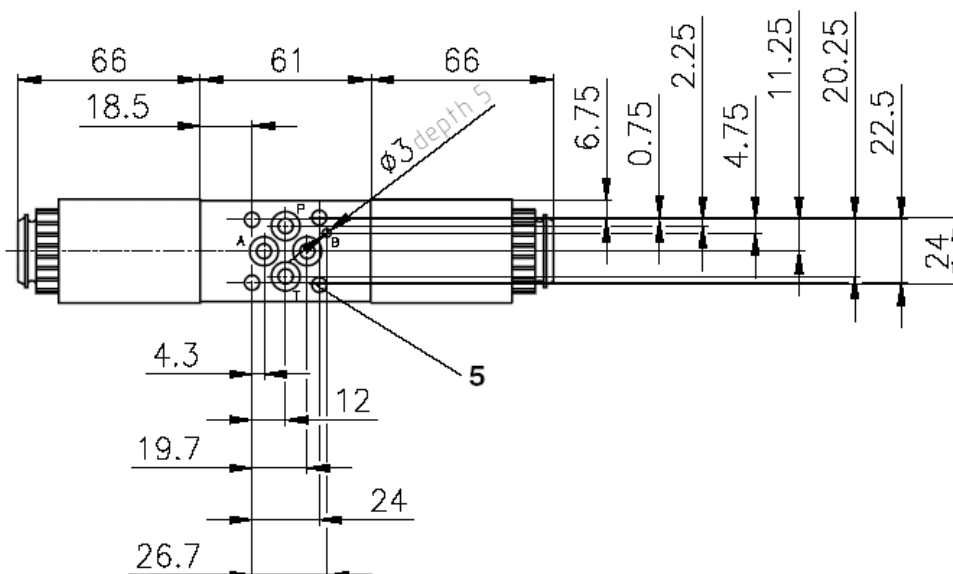
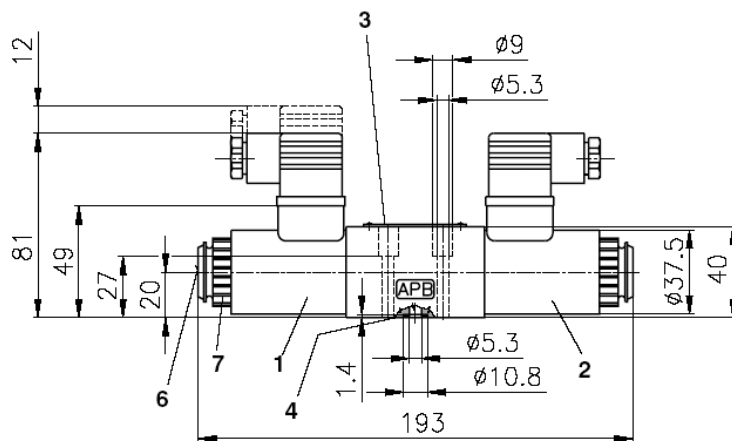
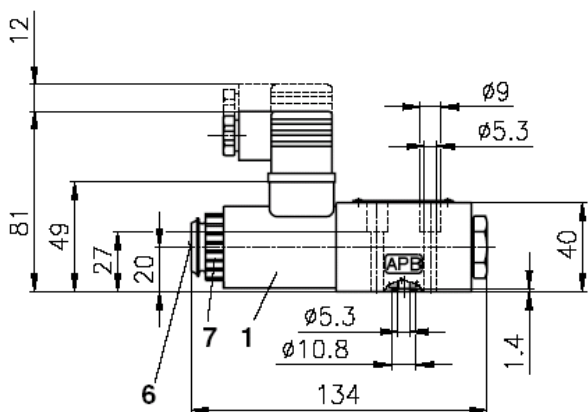

All dimension are mm.

### 11 INSTALLATION

All valves HD2 - \* conform with ISO and CETOP specifications for mounting surface dimensions (see also front page) and for valves height. When assembled to its mounting plate valve HD2 - \* must be fastened with 4 bolts M5 X 35 mm (or M5 x \*\* according to the number of modules) tightened at 8 Nm torque. Leakage between valve and mounting surface is prevented by the positive compression on their seats of 4 seals of QUAD/O Ring.

### 12 HYDRAULIC FLUIDS

Seals and materials used on standard valves HD2 - \* are fully compatible with hydraulic fluids of mineral oil base, upgraded with antifoaming and anti-oxidizing agents. The hydraulic fluid must be kept clean and filtered to ISO 4406 class 19/17/14, or better, and used in a recommended viscosity range from 10 cSt to 60 cSt.

### 13 VERSION "ZC": ZINC PLATED VALVES

Solenoid valves according to "ZC" version have central body zinc plated and protected against every type of corrosion due to saline ambiance or other aggressive chemicals. Zinc thickness are on the valve body: 10-15 µm; and 8/12 µm on solenoids.

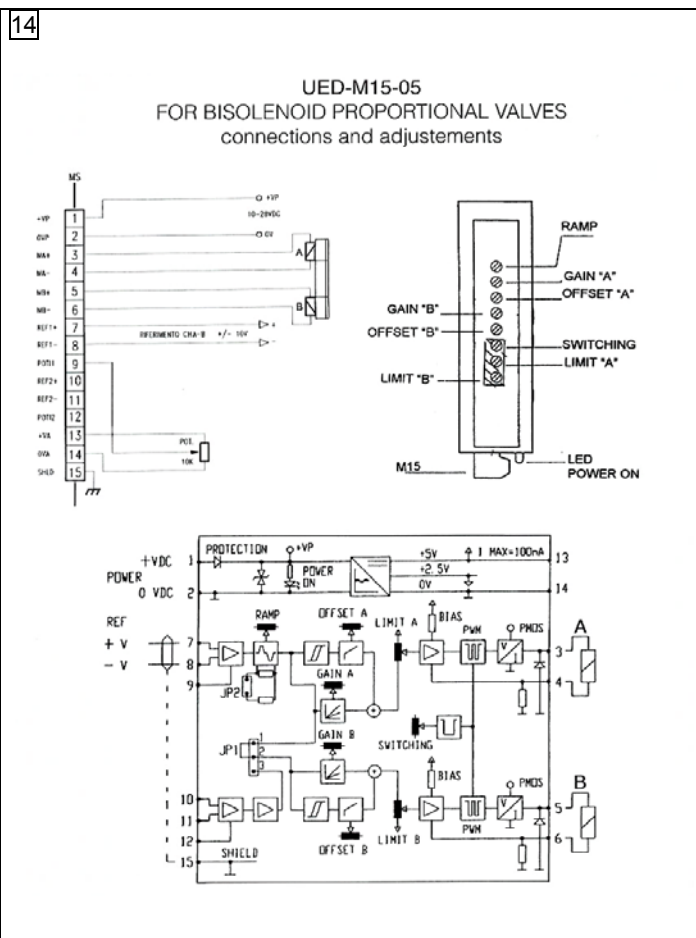

### 14 CHARACTERISTICS OF STANDARD UED-M15-\*\*

See table ED-M15.

Voltage supply: 10 to 28V DC.

Max ripple:  $\pm 10\%$  V supply.

Currents: limit "A" = 2,5 A  
limit "B" = 2,5 A  
bias = 50 mA

Offset "A": 0 to 50% of limit "A"

Offset "B": 0 to 50% of limit "B"

Switching: dither frequency 110Hz

Auxiliary V: VR=5V  $\pm 1\%$  (max 100 Ma)

Ref. signals:

UED-M15-01 and 11 : 0  $\rightarrow$  +10V (or 2,5V  $\rightarrow$  +5V)

UED-M15-05 : -10V  $\leftarrow$  0  $\rightarrow$  +10V (or 0  $\leftarrow$  2,5  $\rightarrow$  +5V)

Ramp time:

From 0,02 sec to 5 sec

Gain "A":

Scale from 0,25A/V to "0" A/V (or from 1 A/V to "0" A/V)

Gain "B":

Scale from 0,25A/V to "0" A/V (or from 1 A/V to "0" A/V)

Temperature:

Permissible range from 25°C to 75°C

EMC protection:

CE "heavy industrial"

Container:

IP-30 protection.

Technology:

SMD, on one card.

## PROPORTIONAL 4-WAY CONTROL VALVES SOLENOID OPERATED – CETOP 03 TYPE HD3 - PS - \*

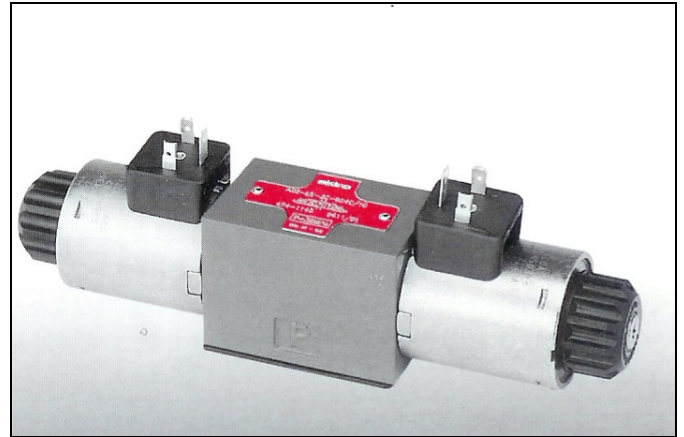
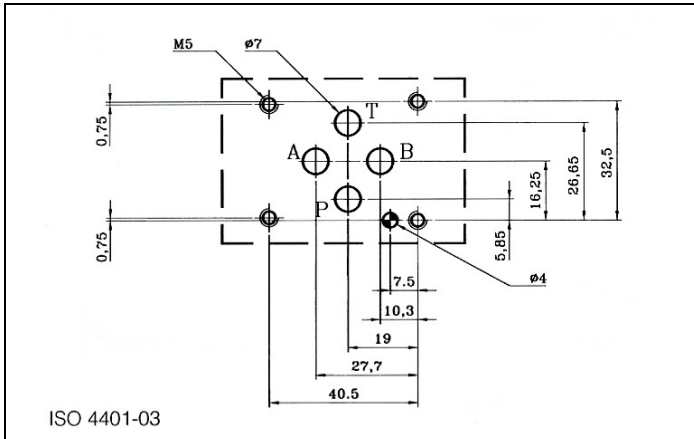

### 2 FUNCTIONAL SYMBOLS

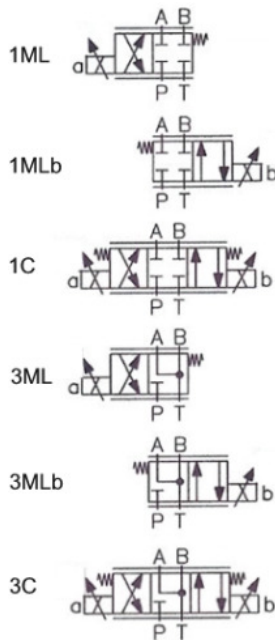

### 1 HOW TO READ THE MODEL CODE FOR VALVES HD3 – PS - \*

**HD3 - PS - (1) (P) - (C) - \*\* - (R2) / 10**  
 ① ② ③ ④ ⑤ ⑥ ⑦ ⑧

- ① HD3 : 4-way directional valve Cetop 03 – Pressure 32 Mpa (320 bar)
- ② PS : Proportional electric control
- ③ (1) : Functional spool type (see 2 7)
  - 1 : closed center (P, A, B, T blocked)
  - 3 : P blocked, A, B, T connected
- ④ (P) : Spool nominal flow – see 4
  - P : 32 l/min with  $\Delta P = 1$  Mpa (10 bar) (PA+BT or PB+AT)
  - R : 16 l/min with  $\Delta P = 1$  Mpa (10 bar) (PA+BT or PB+AT)
  - 05 : 05 l/min with  $\Delta P = 1$  Mpa (10 bar) (PA+BT or PB+AT)
  - D : differential  $Q_b = 2Q_a$ : 32/16 l/min with  $\Delta P = 1$  Mpa (10 bar)
- ⑤ (C) : Solenoid(s) and springs arrangements – see 7
  - C : 2 sol., spool is springs centred
  - ML : 1 sol. (“a”) spool is centred + 1 end position
  - MLb : 1 sol. (“b”) spool is centred + 1 end position
- ⑥ \*\* : Options and variants:
  - K : extended manual overrides – see 9
  - AK : extended manual overrides with air bleeding valves– see 9
  - ZC : zinc plated valves – see 13
- ⑦ (R2) : Type of coil(s) and supply voltages – see 6 14
  - R2 : R= 2,3  $\Omega$  standard for V12DC; R3 : R= 4,5  $\Omega$
  - R4 : R=13,4  $\Omega$  standard for V24DC; R5 : R=18,6  $\Omega$
- ⑧ 10 : Design number (progressive) of the valve.

### 3 DESCRIPTION

The spool ⑫ shifts in to the valves body ⑪ subject to the action of springs ⑬ and proportional solenoid ①.

Spool ⑫, depending from its shape and its position in the valves body ⑪, opens and/or closes passages between P, A, B, T ports, thus controlling the direction and the rate of the hydraulic flow. Solenoid ① is energized by electric current flowing-in through cables; in case of electric cut-offs, the spool can be manually shifted by acting on the emergency pins ⑤, located at the end of the solenoids and accessible through the retaining nuts ⑩.

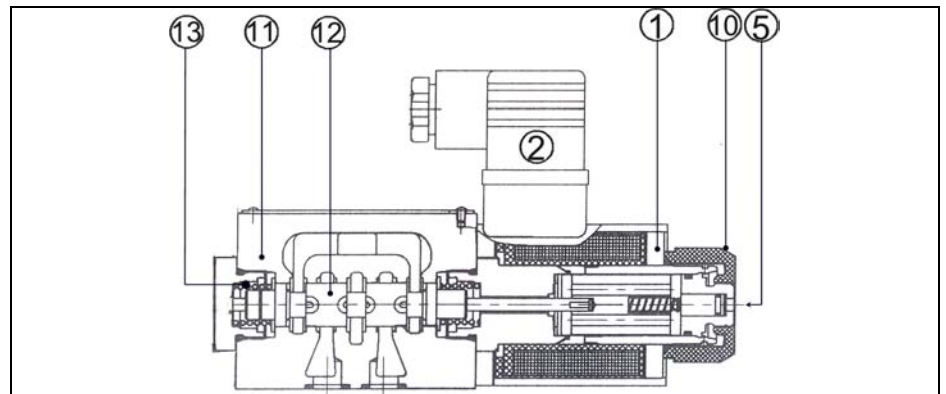

### 4 TYPICAL DIAGRAMS

Typical flow curves of valves HD3 – PS - \*, with spools type P, R, 05 – see 1, in standard configuration measured with mineral oil at 36 cSt and at 50°C at  $\Delta P=01$  Mpa (10 bar) for flow P → B A → T

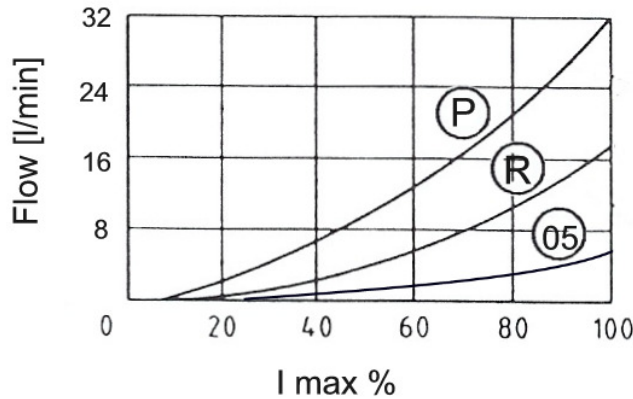

### 5 TECHNICAL DATA

Nominal flow rates	5, 16, 32 l/min – see 1
Maximum nominal pressure (P,A,B)	32 Mpa (320 bar)
Maximum pressure at T port	16 Mpa (160 bar)
Maximum rec. Pressure drops	10 Mpa (100 bar) see 8
Electric characteristics	See 6
Protection	DIN 40050 IP 67
Duty cycle	100%
Service life	$\geq 10^7$ cycles
Dimensions	See 10
Installation	See 11 14
Mass	Approx 1,6 / 2,1 kg.

### 7 SPOOL IDENTIFICATION AND NOMINAL FLOW RATES

Nominal Flow rate 5 l/min	
	HD3-PS-105ML-R*
	HD3-PS-305ML-R*
	HD3-PS-105MLb-R*
	HD3-PS-305MLb-R*
	HD3-PS-105C-R*
	HD3-PS-305C-R*
Nominal Flow rate 16 l/min	
	HD3-PS-1RML-R*
	HD3-PS-3RML-R*
	HD3-PS-1RMLb-R*
	HD3-PS-3RMLb-R*
	HD3-PS-1RC-R*
	HD3-PS-3RC-R*
Nominal Flow rate 32 l/min	
	HD3-PS-1PML-R*
	HD3-PS-3PML-R*
	HD3-PS-1PMLb-R*
	HD3-PS-3PMLb-R*
	HD3-PS-1PC-R*
	HD3-PS-3PC-R*
Differential flow: $Q_b=2Q_a$ (example P→B=32 l/min and A→T= 16 l/min)	
	HD3-PS-1DC-R*
	HD3-PS-3DC-R*

### 6 ELECTRIC CHARACTERISTICS

Valves type HD3-PS-\* are operated by proportional solenoids that are rated for an average max power of 13,5 w.

The values of nominal max. current are:

for coils type R2 ( 2,3  $\Omega$ ): I max = 2,4 A

R3 ( 4,5  $\Omega$ ): I max = 1,7 A

R4 (13,4  $\Omega$ ): I max = 1,0 A

R5 (18,6  $\Omega$ ): I max = 0,85 A

Currents to hydraulic proportional valves are normally supplied by an electronic driver based on PWM mode of operation, capable of full control of min and max values of current for drivers type UED-M15 – see 14.

### 8 FLOW RATES AND PRESSURE DIFFERENTIAL

For a given  $\Delta P$  on a given valve the flow rates are proportional to the driving current (see 4); for a given driving current on a given valve, the flow rates increase with the increasing of the  $\Delta P$  up to certain limits. Typical limit curves are:

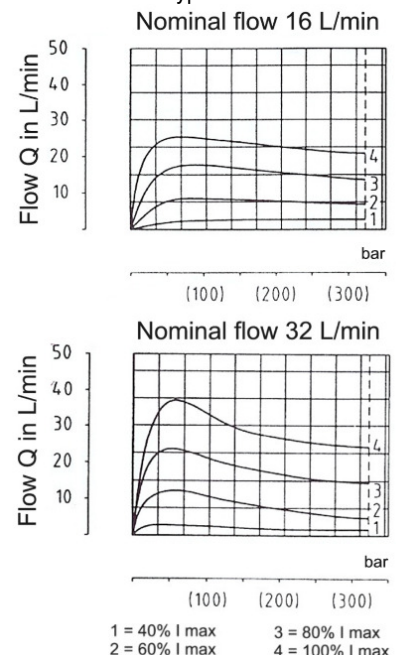

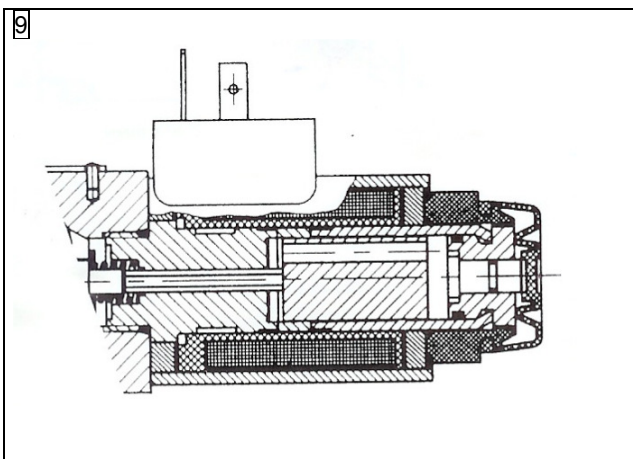

9

### VERSION "K": EXTENDED EMERGENCY PIN

Solenoid valves according to "K" version have extended emergency actuator pins protruding from the solenoid shape, that permit a quick and easy "Hand operation" of the valves, without the need of any tool.

The actuator pin and the end of the solenoid are protected by a flexible rubber cap that makes easy operation and protects from moisture and water splashes.

### VERSION "AK": EXTENDED PIN AND AIR VALVES.

Proportional valves according to "AK" version have extended emergency actuator pins that incorporate air bleeding valves, to purge air from the solenoid tube for a simplified start-up of the system.

The actuator pin and the end of the solenoid are protected by a flexible rubber cap that makes easy operation and protects from moisture and water splashes.

## 10 INSTALLATION DIMENSIONS

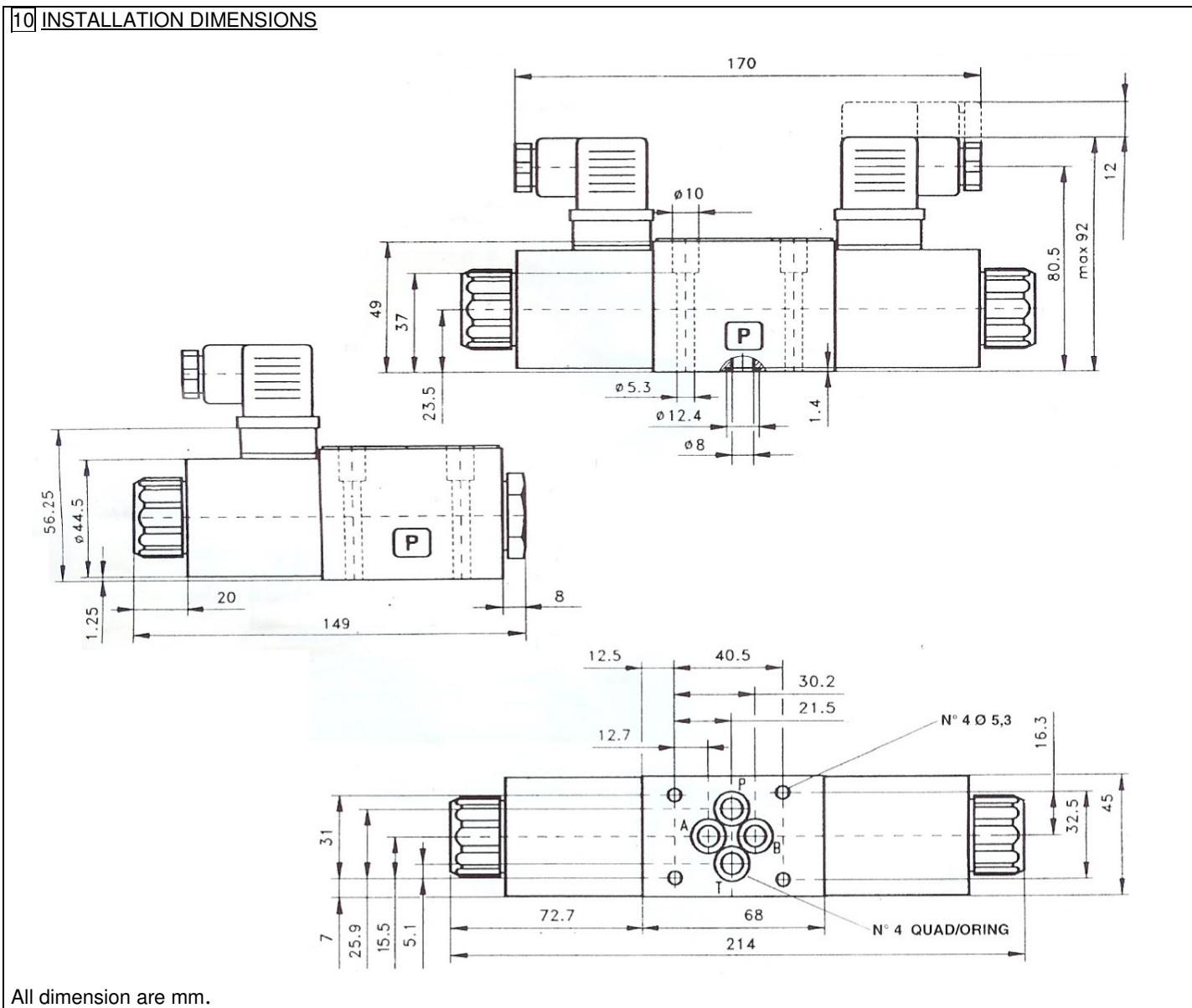

### 11 INSTALLATION

All valves HD3 - \* conform with ISO and CETOP specifications for mounting surface dimensions (see also front page) and for valves height. When assembled to its mounting plate valve HD3 - \* must be fastened with 4 bolts M5 X 45 mm (or M5 x \*\* according to the number of modules) tightened at 8 Nm torque.

Of special interest is the mounting of pressure compensator modules with HD3-P proportional valves – see 15.

Leakage between valve and mounting surface is prevented by the positive compression on their seats of 4 seals of QUAD/O Ring type 9,25x1,68x1,68.

### 12 HYDRAULIC FLUIDS

Seals and materials used on standard valves HD3 - \* are fully compatible with hydraulic fluids of mineral oil base, upgraded with antifoaming and anti-oxidizing agents.

The hydraulic fluid must be kept clean and filtered to ISO 4406 class 19/17/14, or better, and used in a recommended viscosity range from 10 cSt to 60 cSt.

### 13 VERSION "ZC": ZINC PLATED VALVES

Solenoid valves according to "ZC" version have central body zinc plated and protected against every type of corrosion due to saline ambience or other aggressive chemicals. Zinc thickness are on the valve body: 10-15 µm; and 8/12 µm on solenoids.

### 14

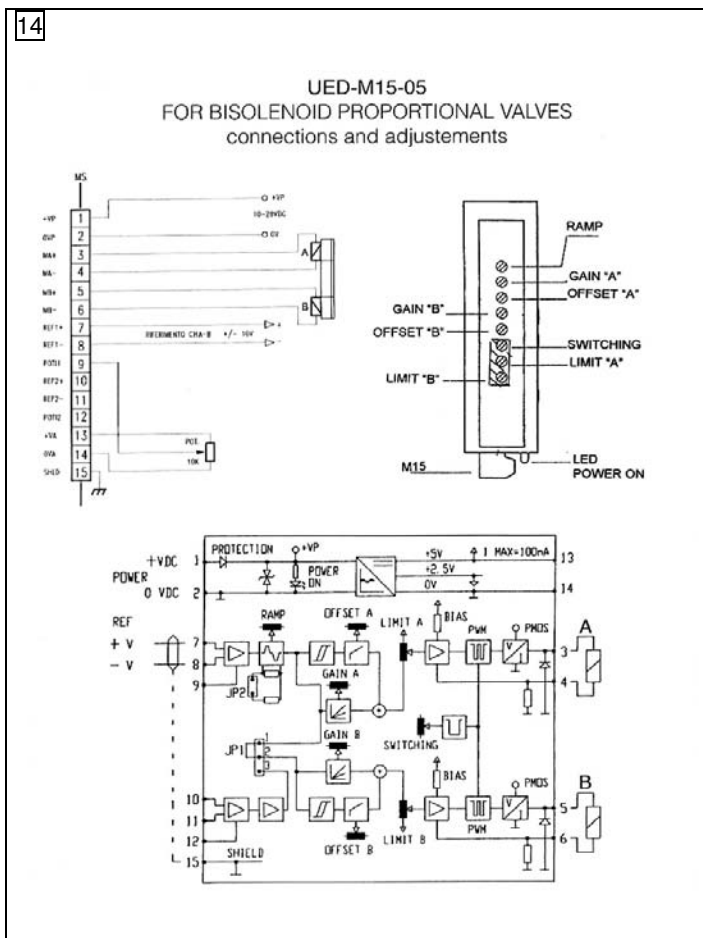

### 14 CHARACTERISTICS OF STANDARD UED-M15-\*\*

See table ED-M15.

Voltage supply: 10 to 28V DC.

Max ripple:  $\pm 10\%$  V supply.

Currents: limit "A" = 2,5 A

limit "B" = 2,5 A

bias = 50 mA

Offset "A": 0 to 50% of limit "A"

Offset "B": 0 to 50% of limit "B"

Switching: dither frequency 110Hz

Auxiliary V: VR=5V  $\pm 1\%$  (max 100 Ma)

Ref. signals:

UED-M15-01 and 11 : 0  $\rightarrow$  +10V (or 2,5V  $\rightarrow$  +5V)

UED-M15-05 : -10V  $\leftarrow$  0  $\rightarrow$  +10V (or 0  $\leftarrow$  2,5  $\rightarrow$  +5V)

Ramp time:

From 0,02 sec to 5 sec

Gain "A":

Scale from 0,25A/V to "0" A/V (or from 1 A/V to "0" A/V)

Gain "B":

Scale from 0,25A/V to "0" A/V (or from 1 A/V to "0" A/V)

Temperature:

Permissible range from 25°C to 75°C

EMC protection:

CE "heavy industrial"

Container:

IP-30 protection.

Technology:

SMD, on one card.

### 15

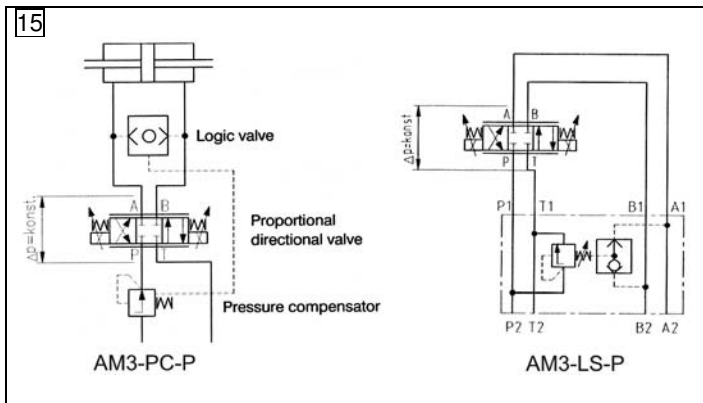

### 15 PRESSURE COMPENSATOR MODULES.

2-way pressure compensator for meter-in application type AM3-PC-P – see table AM-391.

When using the 2-way pressure compensators in meter-in application, shown in the circuit diagram, a constant pressure difference across the metering edge of the proportional direction valve is held. In this case, the pressure variations due to loading changes, as well as pump pressure changes, are compensated. That means that a pressure change cannot result in flow increase.

3-way pressure compensator type AM3-LS-P (See table AM-390) is able to operate as "load sensing" device, by discharging at T port, at the same pressure of the user, the flow that exceeds the flow rates required by the controlled opening of the proportional 4-way valve.



**PROPORTIONAL 4-WAY CONTROL VALVES  
SOLENOID OPERATED – CETOP 05  
TYPE HD5 - PS - \***

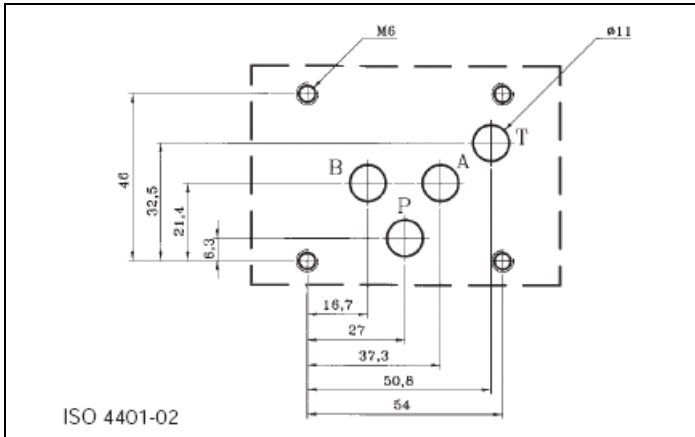

**2 FUNCTIONAL SYMBOLS**

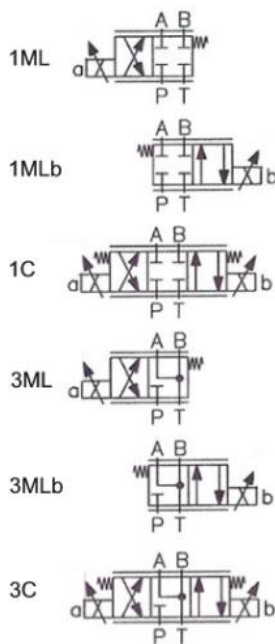

**1 HOW TO READ THE MODEL CODE FOR VALVES HD5 – PS - \***

**HD5 - PS - (1) (P) - (C) - \*\* - (R2) / 10**  
 ① ② ③ ④ ⑤ ⑥ ⑦ ⑧

- ① HD5 : 4-way directional valve Cetop 05 – Pressure 32 Mpa (320 bar)
- ② PS : Proportional electric control
- ③ (1) : Functional spool type (see 2 7)
  - 1 : closed center (P, A, B, T blocked)
  - 3 : P blocked, A, B, T connected
- ④ (P) : Spool nominal flow – see 4
  - P : 63 l/min with  $\Delta P = 1$  Mpa (10 bar) (PA+BT or PB+AT)
  - R : 32 l/min with  $\Delta P = 1$  Mpa (10 bar) (PA+BT or PB+AT)
  - D : differential  $Q_b = 2Q_a$ : 63/32 l/min with  $\Delta P = 1$  Mpa (10 bar)
- ⑤ (C) : Solenoid(s) and springs arrangements – see 7
  - C : 2 sol., spool is springs centred
  - ML : 1 sol. (“a”) spool is centred + 1 end position
  - MLb : 1 sol. (“b”) spool is centred + 1 end position
- ⑥ \*\* : Options and variants:
  - K : extended manual overrides – see 9
  - AK : extended manual overrides with air bleeding valves– see 9
  - ZC : zinc plated valves – see 13
- ⑦ (R2) : Type of coil(s) and supply voltages – see 6 14
  - R1 : R= 3,78  $\Omega$
  - R2 : R= 4,7  $\Omega$  standard for V12DC;
  - R4 : R=13,9  $\Omega$  standard for V24DC;
- ⑧ 10 : Design number (progressive) of the valve.

**3 DESCRIPTION**

The spool ⑫ shifts in to the valves body ⑪ subject to the action of springs ⑬ and proportional solenoid ①.  
 Spool ⑫, depending from its shape and its position in the valves body ⑪, opens and/or closes passages between P, A, B, T ports, thus controlling the direction and the rate of the hydraulic flow. Solenoid ① is energized by electric current flowing-in through cables; in case of electric cut-offs, the spool can be manually shifted by acting on the emergency pins ⑤, located at the end of the solenoids and accessible through the retaining nuts ⑩.

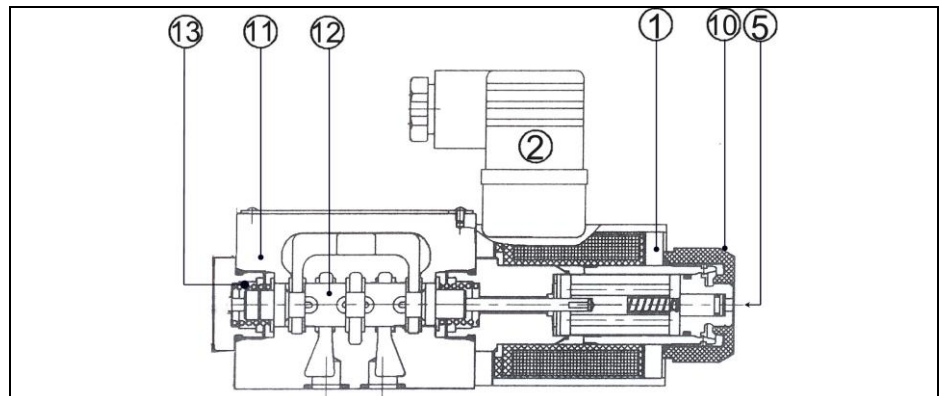

#### 4 TYPICAL DIAGRAMS

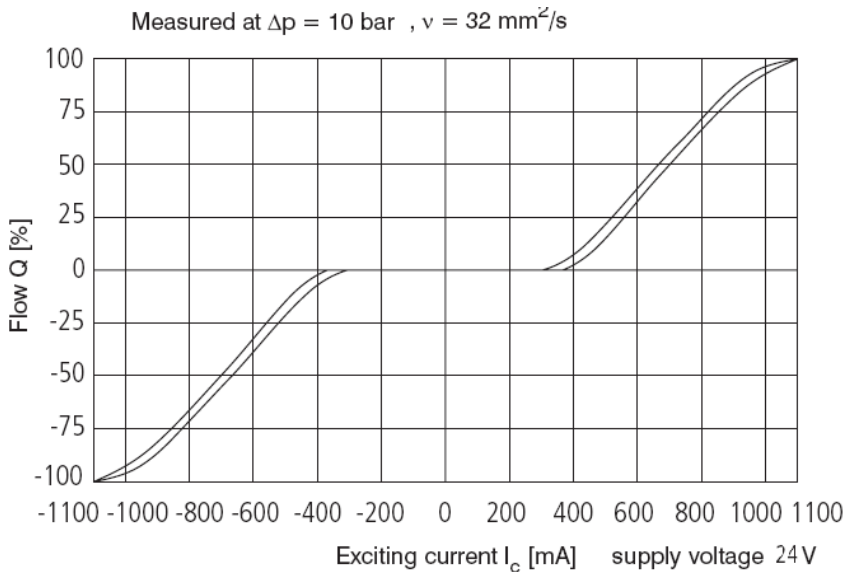

#### 5 TECHNICAL DATA

Nominal flow rates	32, 63 l/min – see 11
Maximum nominal pressure (P,A,B)	32 Mpa (320 bar)
Maximum pressure at T port	21 Mpa (210 bar)
Maximum rec. Pressure drops	10 Mpa (100 bar) see 8
Electric characteristics	See 6
Protection	DIN 40050 IP 67
Duty cycle	100%
Service life	$\geq 10^7$ cycles
Dimensions	See 10
Installation	See 11 14
Mass	Approx 4,3 / 5,8 kg.

#### 6 ELECTRIC CHARACTERISTICS

Valves type HD5-PS-\* are operated by proportional solenoids that are rated for an average max power of 13,5 W.

The values of nominal max. current are:  
 for coils type R1 ( 3,78  $\Omega$ ):  $I_{\text{max}} = 2,4 \text{ A}$   
 R2 ( 4,7  $\Omega$ ):  $I_{\text{max}} = 1,9 \text{ A}$   
 R4 (13,9  $\Omega$ ):  $I_{\text{max}} = 1,1 \text{ A}$

Currents to hydraulic proportional valves are normally supplied by an electronic driver based on PWM mode of operation, capable of full control of min and max values of current for drivers type UED-M15 – see 14.

#### 8 FLOW RATES AND PRESSURE DIFFERENTIAL.

For a given  $\Delta P$  on a given valve the flow rates are proportional to the driving current (see 4); for a given driving current on a given valve, the flow rates increase with the increasing of the  $\Delta P$  up to certain limits. Typical limit curves are:

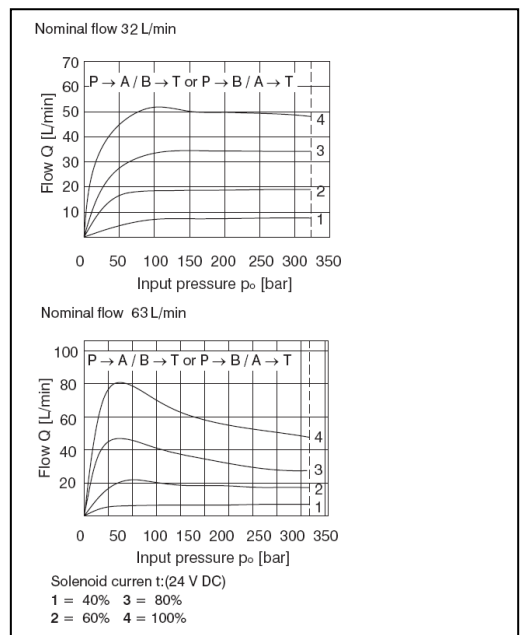

#### 7 SPOOL IDENTIFICATION AND NOMINAL FLOW RATES

Nominal Flow rate 32 l/min	
	HD5-PS-1RML-R*
	HD5-PS-3RML-R*
	HD5-PS-1RMLb-R*
	HD5-PS-3RMLb-R*
	HD5-PS-1RC-R*
	HD5-PS-3RC-R*
Nominal Flow rate 63 l/min	
	HD5-PS-1PML-R*
	HD5-PS-3PML-R*
	HD5-PS-1PMLb-R*
	HD5-PS-3PMLb-R*
	HD5-PS-1PC-R*
	HD5-PS-3PC-R*
Differential flow: $Q_b=2Q_a$ (example $P \rightarrow B=63 \text{ l/min}$ and $A \rightarrow T= 32 \text{ l/min}$ )	
	HD5-PS-1DC-R*
	HD5-PS-3DC-R*

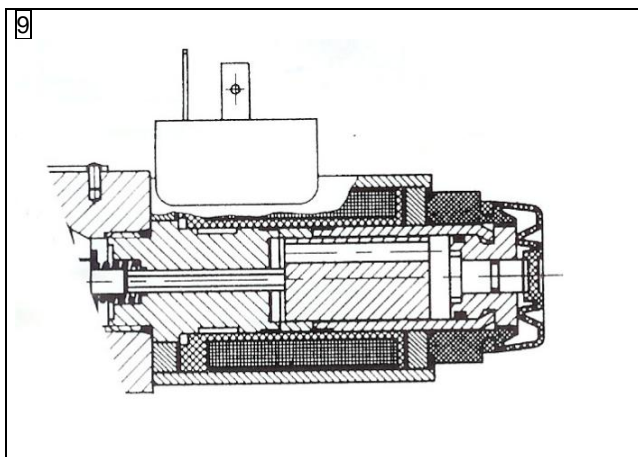

9

### VERSION "K": EXTENDED EMERGENCY PIN

Solenoid valves according to "K" version have extended emergency actuator pins protruding from the solenoid shape, that permit a quick and easy "Hand operation" of the valves, without the need of any tool.

The actuator pin and the end of the solenoid are protected by a flexible rubber cap that makes easy operation and protects from moisture and water splashes.

### VERSION "AK": EXTENDED PIN AND VALVE AIR BLEEDING

Proportional valves according to "AK" version have extended emergency actuator pins that incorporate air bleeding valves, to purge air from the solenoid tube for a simplified start-up of the system.

The actuator pin and the end of the solenoid are protected by a flexible rubber cap that makes easy operation and protects from moisture and water splashes.

## 10 INSTALLATION DIMENSIONS

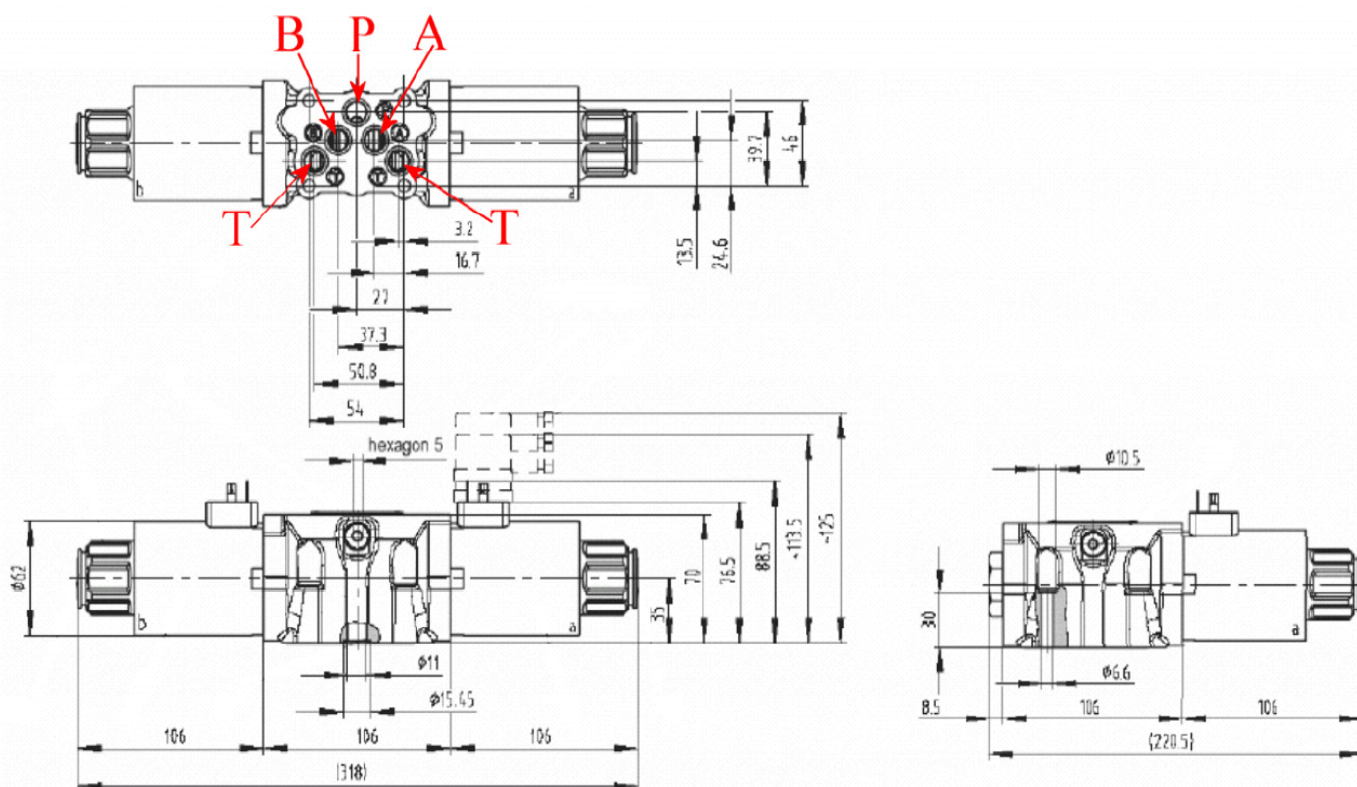

All dimension are mm.

## 11 INSTALLATION

All valves HD5-PS-\* conform with ISO and CETOP specifications for mounting surface dimensions (see also front page) and for valves height.

When assembled to its mounting plate, valve HD5-ES-\* must be fastened with 4 fixing bolts (socket head screws to ISO 4762) M6 x 40 mm (or M6 x \* according to the number of modules) of class 12,9 (ISO898) tightened at 12 Nm torque.

Leakage between valve and mounting surface is prevented by the positive compression on their seats of 5 seals of Quad-Ring type 12,42 x 1,68 x 1,68 mm.

## 12 HYDRAULIC FLUIDS

Seals and materials used on standard valves HD5 - \* are fully compatible with hydraulic fluids of mineral oil base, upgraded with antifoaming and anti-oxidizing agents.

The hydraulic fluid must be kept clean and filtered to ISO 4406 class 19/17/14, or better, and used in a recommended viscosity range from 10 cSt to 60 cSt.

## 13 VERSION "ZC": ZINC PLATED VALVES

Solenoid valves according to "ZC" version have central body zinc plated and protected against every type of corrosion due to saline ambience or other aggressive chemicals. Zinc thickness are on the valve body: 10-15 µm; and 8/12 µm on solenoids.

## 14

UED-M15-05  
FOR BISOLENOID PROPORTIONAL VALVES  
connections and adjustments

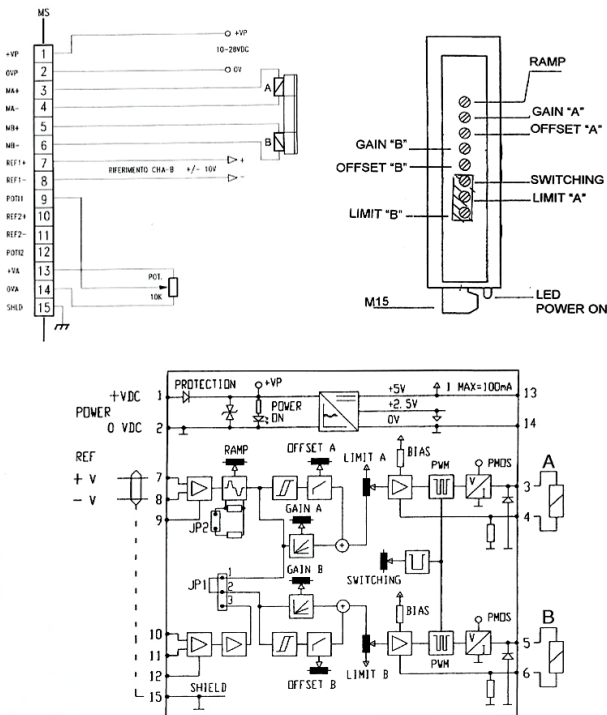

## 14 CHARACTERISTICS OF STANDARD UED-M15-\*\*

See table ED-M15.

Voltage supply: 10 to 28V DC.

Max ripple:  $\pm 10\%$  V supply.

Currents: limit "A" = 2,5 A  
 limit "B" = 2,5 A  
 bias = 50 mA

Offset "A": 0 to 50% of limit "A"

Offset "B": 0 to 50% of limit "B"

Switching: dither frequency 110Hz

Auxiliary V: VR=5V  $\pm 1\%$  (max 100 Ma)

Ref. signals:  
 UED-M15-01 and 11 : 0  $\rightarrow$  +10V (or 2,5V  $\rightarrow$  +5V)  
 UED-M15-05 : -10V  $\leftarrow$  0  $\rightarrow$  +10V (or 0  $\leftarrow$  2,5  $\rightarrow$  +5V)

Ramp time:  
 From 0,02 sec to 5 sec

Gain "A":  
 Scale from 0,25A/V to "0" A/V (or from 1 A/V to "0" A/V)

Gain "B":  
 Scale from 0,25A/V to "0" A/V (or from 1 A/V to "0" A/V)

Temperature:  
 Permissible range from 25°C to 75°C

EMC protection:  
 CE "heavy industrial"

Container:  
 IP-30 protection.

Technology:  
 SMD, on one card.