

# LUEN

*DIIT* Group



VALVOLE DI BILANCIAMENTO  
E BLOCCO  
COUNTERBALANCE VALVES

Con il fine di migliorare costantemente la qualità dei nostri prodotti, ci riserviamo il diritto di modificarne in qualsiasi momento le caratteristiche senza preavviso.

È responsabilità della spettabile clientela la costante verifica dei dati contenuti nei cataloghi.

Questo catalogo annulla e sostituisce i precedenti.

In order to constantly improve our products quality, we take the right to make changes to the catalogues at any time without notice.

Customers have the responsibility to continuously check all the information in the catalogues.

This catalogue cancels and replaces the previous ones.

Versione - Version 01/092016

## FLUIDO IDRAULICO

Il fluido idraulico deve avere caratteristiche fisiche, lubrificanti e chimiche tali da renderlo idoneo all'impiego in impianti oleodinamici, come ad esempio olio idraulico a base minerale HL DIN 51524 Parte 1 e HLP DIN 51524 Parte 2.

Il grado di viscosità ISO 3448 viene indicato con lettere ISO VG seguite da un numero che rappresenta la viscosità cinematica MEDIA a 40°C in mm<sup>2</sup>/s o centiStokes cSt.

## HYDRAULIC FLUID

Hydraulic fluid must have physical, lubricating and chemical properties suitable for use in hydraulic systems such as, for example, mineral based oil HL DIN 51524 Part 1 and HLP DIN 51524 Part 2.

ISO 3448 viscosity class is expressed by ISO VG followed by one number representing the average kinematic viscosity at 40°C in mm<sup>2</sup>/s or centiStokes cSt.

GRADI DI VISCOSITÀ  VISCOSITY CLASS	VISCOSITÀ CINEMATICA KINEMATIC VISCOSITY		
	max a 0°C max at 0°C	media a 0°C medium at 0°C	max a 100°C max at 100°C
ISO VG 10	90	10	2,4
ISO VG 22	300	22	4,1
ISO VG 32	420	32	5,0
ISO VG 46	780	46	6,1
ISO VG 68	1400	68	7,8
ISO VG 100	2560	100	9,9

## FILTRAZIONE

Premessa: una delle più frequenti cause di avarie negli impianti oleodinamici è l'eccessiva contaminazione dell'olio. Le particelle di impurità, soprattutto quelle dure e abrasive, usurano le superfici dei componenti oleodinamici e danneggiano le sedi di tenuta, provocando trafileamenti interni e malfunzionamenti. Per il corretto funzionamento delle valvole LuEn il livello di contaminazione massimo dell'olio non deve generalmente eccedere i limiti delle classi 19/15 ISO-4406, ovvero 10+11 NAS-1638, salvo eventuali prescrizioni i più restrittive che troverete indicate nelle schede tecniche delle valvole interessate. Rapporto di filtrazione (3x): è un dato che caratterizza ciascun tipo di filtro e rappresenta il rapporto tra il numero di particelle presenti prima e dopo il filtro aventi un diametro maggiore di X micron.

Filtrazione assoluta (ISO 4572): è il diametro X delle particelle più grosse alle quali corrisponde  $3x \geq 75$ .

Classe di contaminazione secondo ISO 4406: viene espressa mediante 2 numeri che indicano rispettivamente la quantità di particelle con diametro superiore a 5 micron e 15 micron presenti in 1mi di olio.

Classe di contaminazione secondo NAS 1638: viene espressa mediante un numero che indica la quantità di particelle di diverse dimensioni presenti in 100 mi di olio.

## CONTAMINATION, FILTRATION

General information: very often the cause of malfunctions in hydraulic systems and components is found to be excessive fluid contamination.

In particular the hard and abrasive particles in the fluid wear the hydraulic components and prevent the poppets from re-seating, with consequent internal leakage and system inefficiency. For the correct operation of LuEn valves it is necessary to ensure that the oil contamination level does not exceed the limits given in class 19/15 ISO-4406, or 10+11 NAS-1638, unless otherwise specified in the relevant technical sheet.

Filtration ratio (3x): it's the ratio between the number of particles before and after the filter with diameter larger than X micron.

Absolute filtration rating (ISO 4572): it's the diameter X of the largest particles with  $13x \geq 75$ .

Contamination class ISO 4406: it's expressed by two scale numbers representing the number of particles larger than 5 micron and larger than 15 micron contained in 1 mi of fluid.

Contamination class NAS 1638: it's expressed by one scale number representing the number of particles of different size ranges contained in 100 mi of fluid.

## CARTUCCE

Di tipo avvitabile, possono venire inserite nell'apposita cavità ricavata direttamente nell'attuatore (cilindro, motore, pompa, ...) o in blocco integrato.

Sono realizzate in Acciaio AV-PB (9SMnPb28 o 32) oppure Ng2Pb (16NiCr4) per i particolari interni di tenuta meccanica. Tutti i particolari interni vengono temprati e sottoposti a rettifica o lappatura in modo da assicurare la massima affidabilità di resistenza. L'involucro esterno viene protetto mediante trattamenti di zincatura bianca o brunitura (nera)

## INSTALLAZIONE DELLE CARTUCCE

Si raccomanda di seguire scrupolosamente la seguente procedura:

- assicurarsi che la cartuccia non sia sporca o in cattive condizioni.
- assicurarsi che gli O-ring e gli anelli antiestrusione siano integri e correttamente montati.
- l'O-ring deve essere montato verso la bocca a pressione più alta se vi è un solo anello antiestrusione, oppure tra due anelli antiestrusione se entrambe le bocche possono ricevere olio ad alta pressione.
- immergere la cartuccia in olio pulito.
- avvitare la cartuccia A MANO finché si incontra l'O-Ring, quindi serrare con chiave dinamometrica alla coppia di serraggio riportata sulle pagine di catalogo relative alla cartuccia.

## TARATURE

Le valvole LuEn sono tarate dalla Casa Costruttrice al valore di pressione standard indicato nel corrispondente foglio catalogo. Qualora sia necessario modificare il valore di taratura standard, assicurarsi di non uscire dal campo di taratura corrispondente alla molla indicata sulla scheda tecnica relativa.

L'olio utilizzato per la taratura è di tipo ISO VG 32, a 30°C di temperatura.

## CARTRIDGES

Screw type, they can be fitted directly into the cavity in the actuator (cylinder, motor, pump, etc.) or in the integrated block. The valves are made of steel AV-PB (9SMhPb28 or 32) or of Ng2Pb (16NCR4) for the internal mechanical blocks. All the internal parts are hardened and ground or lapped to ensure the maximum reliability and resistance. The external face is either zinc-plated (white) or burnished (black).

## CARTRIDGE INSTALLATION

It's recommended to strictly follow these steps:

- inspect the cartridge to ensure that it is in good condition and no external contaminant is present.
- check that O-rings and back-up rings are intact and correctly positioned.
- The O-ring should be towards the higher pressure port, if only one back-up ring is present, or between double back-up rings if both ports receive high pressure.
- dip the cartridge in clean oil.
- screw the cartridge in BY HAND until the O-ring is met, then tighten with a wrench to the torque specified in the cartridge catalogue page.

## PRESSURE SETTING

LuEn valves are supplied pre-set at the standard pressure setting shown by the relevant catalogue sheet. Whenever the application requires a re-adjustment, please ensure that the limits of the given pressure range are never exceeded.

Hydraulic fluid used for pressure setting is ISO VG 32 type, at 30°C temperature.

## COLLETTORI

### VALVOLE CON COLLETTORE IN ACCIAIO

Il collettore viene realizzato in Acciaio AV-PB (11SMnPb37) e viene protetto mediante brunitura (nera) o zincatura bianca.

### VALVOLE CON COLLETTORI IN ALLUMINIO

Sono realizzati con alluminio estruso ad alta resistenza, appositamente studiato per applicazioni oleoidrauliche ad elevate pressioni di esercizio. A richiesta può essere sottoposto a trattamento di anodizzazione indurente (durezza 120-130HRw per una profondità di 2-3 micron) color grigio, consentendo tenute meccaniche ad alta precisione ed miglior resistenza nei filetti dei condotti di collegamento e dei vari tappi di chiusura e regolazione.

Sono idonee per impieghi ove la pressione massima indicata per ciascun tipo di valvola viene raggiunta solo occasionalmente o per impieghi a pressione ridotta continuativa. Per impieghi gravosi o nei casi ove la pressione massima ammissibile venga raggiunta frequentemente LuEn sviluppa una vasta gamma di valvole con collettori in acciaio.

### TIPI DI CAVITÀ

- CE...N Cavità normal izzata per cartucce
- CE...L Cavità per cartucce di disegno specifico LuEn
- CE...LN Cavità compatibile con altri costruttori
- CI...LN Cavità per valvole non a cartuccia. I particolari interni vengono assemblati direttamente sul blocco (in acciaio o alluminio). Tale soluzione consente una maggior compattezza e minori perdite di carico. Vengono utilizzati pattini in teflon per proteggere gli OR dall'usura ed ottenere sempre il massimo delle prestazioni.

Sono disponibili i disegni tecnici relativi alle cavità di tipo CE. Non vengono invece forniti disegni di cavità interne del tipo CI in quanto l'operazione di assemblaggio di valvole direttamente su collettore può essere effettuata unicamente nello stabilimento LuEn da personale specializzato, sotto rigorosi controlli dimensionali.

## BODIES

### STEEL BODIES

The bodies are made of Steel AV-PB (11SMnPb37) and burnished (black) or zinc-plated (white).

### VALVES WITH AN ALUMINIUM BODY

The bodies are made of high resistance extruded aluminium, designed for high pressure hydraulic applications. For a higher hardness degree, they can be gray anodized upon request (hardness 120-130 HRw, 2-3 micron deep). This allows high precision mechanical blocks and a better resistance of the connecting threads and of the plugs and of the adjustment plugs.

These bodies can be used in applications where the maximum pressure (set for each single valve type) is reached only occasionally or for applications with a continuous moderate pressure. LuEn has developed a wide range of steel bodies designed for heavy duties or for the applications in which the maximum pressure allowed is frequently reached.

### CAVITIES

- CE...N Normalized cavity for cartridges
- CE...L LuEn proprietary cartridge cavity
- CE...LN Cavity compatible other manufacturers
- CI...LN Non cartridge valve cavity. The single parts are assembled directly on the body (in aluminium or steel). This allows a good compact design and low pressure drops. Special Teflon rings are used to protect the OR from wearing to always allow best performances.

CE cavity drawings are at the customer's disposal. CI cavities are not published because the valves assembly directly on the bodies can be performed only at LuEn factory by specialized personnel and under strict dimensionai controls.

## ATTACCHI

Gli attacchi filettati sono normalmente del tipo GAS cilindrico (BSPP) nelle dimensioni da 1/4" a 1"1/4. Altri tipi di attacchi filettati sono disponibili a richiesta. A disposizione una vasta gamma standard, METRICO - NPT - SAE-6000 - CETOP e flangiature specifiche per i modelli più diffusi dei motori idraulici.

## GUARNIZIONI E ANELLI DI TENUTA

### O-RING

Gli O-Ring vengono utilizzati per realizzare tenute statiche (quando non sussistono movimenti reciproci tra le parti) e dinamiche (quando ci si trova in presenza di movimento relativo delle parti).

La scelta della dimensione ottimale dell'O-Ring è fondamentale per realizzare la tenuta.

Si raccomanda, in caso di necessità di sostituzione, di utilizzare gli stessi O-Ring specificati nella documentazione LuEn s.r.l..

Gli O-Ring vengono forniti standard con miscela NBR (nitrile-butadiene) (durezza 70· Shore A) secondo DIN ISO 1229 e, sono idonei per temperature da -20°C a +100°C. Per temperature più alte, a richiesta, si raccomandano mescole diverse (es. Viton).

### ANELLI BACK-UP

Ove risulta possibile l'espulsione degli O-Ring dalle loro sedi a causa della pressione vengono utilizzati: anelli anti-estrusione Parbak (durezza 90· Shore A), anelli di scorrimento in teflon (PTFE).

Nel caso sia presente un solo anello antietrusione, va sempre montato sul lato non in pressione della tenuta rispetto all'O-Ring.

## CONSERVAZIONE A MAGAZZINO DELLE VALVOLE NUOVE

Le valvole vanno conservate protette nel loro involucro termoretraibile, lontane dall'irraggiamento solare o da sorgenti di calore e di ozono, che producono un invecchiamento precoce delle guarnizioni (evitare la vicinanza con motori elettrici funzionanti) in un ambiente con temperatura tra -20°C e +50°C.

## PORTS

port are usually GAS type (BSPP) from ;4" to 1"1/4. Different ports sizes are available on request. A range of standard flanges (SAE, CETOP) and hydraulic motor specific flanges is also available.

### O-RING

The O-Rings are used to realize static (when the parts don't move) and dynamic (when there's movement between the parts) seal.

The right dimension of the O-Ring is fundamental to realize the seal. It's highly recommended, in case the O-Ring has to be replaced, to use exactly the some models specified in the LuEn documentation. O-Rings are supplied standard in NBR (hardness SO' Shore A) D1 N ISO 1229.

Where the O-Ring is subject to expulsion from its seat, due to pressure, Parbak rings (hardness 90 Shore A) are used. When a single Parbak ring is used, it should always be mounted on the which is not under pressure with respect to the O-Ring.

## STOCKING OF NEW VALVES

Encapsulated by a protective wrapping, the valves shall not be exposed to direct sun light nor to sources of heat or ozone (like electric motors running), at a temperature between -20°C and +50°C.

1

**VALVOLE DI BILANCIAMENTO E BLOCCO  
OVERCENTER VALVES**

		<p><b>VALVOLE A CARTUCCIA</b> <i>CARTRIDGE VALVES</i></p>	<p>PAG. 1-10</p>
		<p><b>VALVOLE A SEMPLICE EFFETTO IN LINEA</b> <i>SINGLE ACTING VALVES WITH IN-LINE BODY</i></p>	<p>PAG. 11-28</p>
		<p><b>VALVOLE A DOPPIO EFFETTO IN LINEA</b> <i>DOUBLE ACTING VALVES WITH IN-LINE BODY</i></p>	<p>PAG. 29-44</p>
		<p><b>VALVOLE CON COLLETTORE FLANGIABILE</b> <i>VALVES WITH FLANGIABLE BODY</i></p>	<p>PAG. 45-64</p>
		<p><b>VALVOLE CON COLLETTORE CETOP</b> <i>VALVES WITH CETOP INSTALLATION</i></p>	<p>PAG. 65-72</p>
		<p><b>VALVOLE CON FLANGIATURA MOTORE</b> <i>MOTOR FLANGEABLE VALVES</i></p>	<p>PAG. 73-86</p>

# OWC-60-...

VALVOLA BILANCIAMENTO, BLOCCO E CONTROLLO MOVIMENTO A CARTUCCIA

CARTRIDGE COUNTERBALANCE VALVES WITH WITHOUT BODY

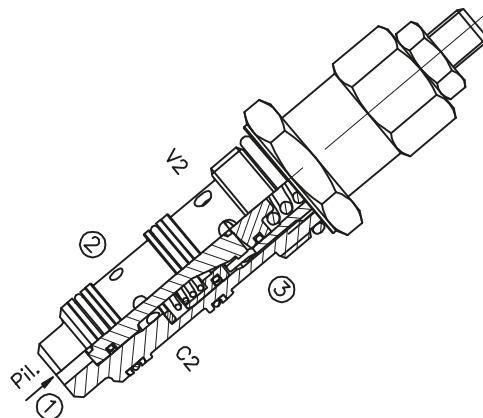
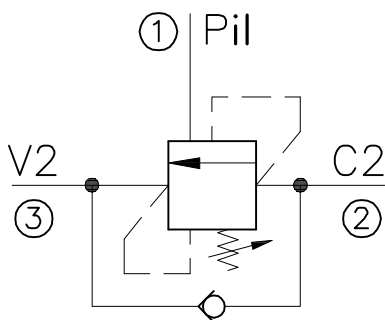

## CARATTERISTICHE

Luce nominale	<b>DN 10</b>
Portata min/max	<b>1/60 l/min - 0.26/15.9 GPM</b>
Pressione max. di picco	<b>450 bar - 6525 PSI</b>
Pressione max. di taratura	<b>350 bar - 5075 PSI</b>
Rapporto di pilotaggio standard	<b>4.25 : 1</b>
Temperatura ambiente	<b>-30°C + 50°C</b>
Temperatura olio	<b>-30°C + 80°C</b>
Filtraggio consigliato	<b>30 micron</b>
Coppia di serraggio	<b>116÷128 Nm</b>
Peso	<b>0.300 Kg</b>

## PERFORMANCE

Rated size
Min/max flow-rate
Max peak pressure
Max setting pressure
Standard pilot ratio
Room temperature
Oil temperature
Recommended filtration
Tightening torque
Weight

### NOTE:

La taratura deve essere **1.3** volte maggiore della pressione indotta dal carico.

Valve should be set at **1.3** times load induced pressure.

### ESEMPIO/EXAMPLE:

Pressione di lavoro max:

Max working pressure:

**350 bar / 1.3 = 270 bar**

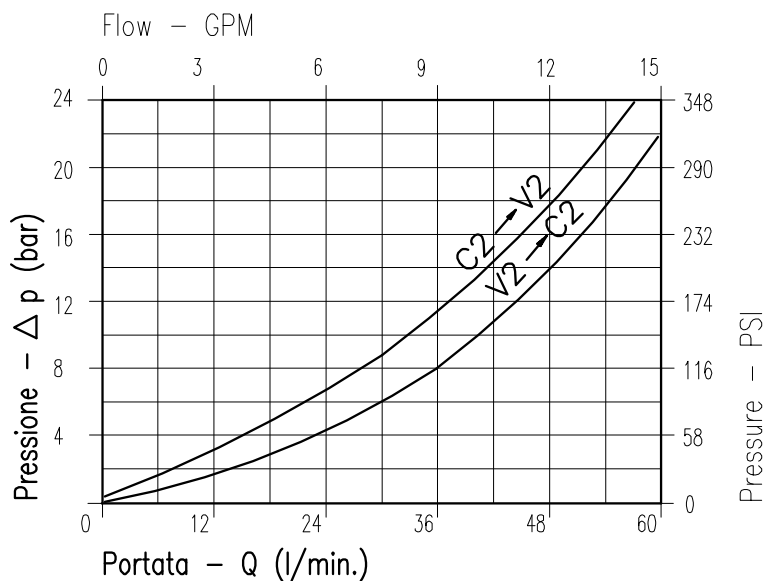

Viscosità olio 46 cSt a 50°C  
Oil viscosity 46 cSt at 50°C



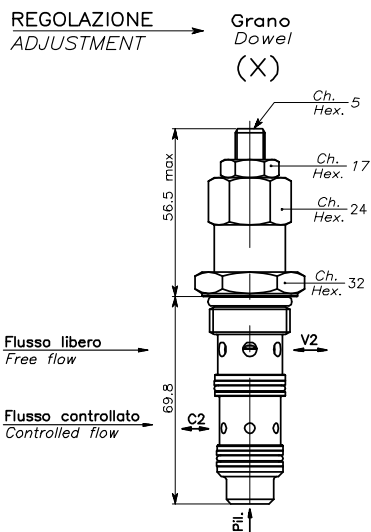

## CAVITÀ / CAVITY

### CE.025.N

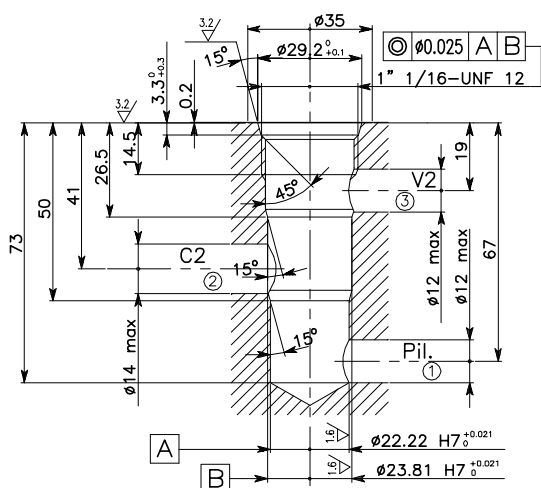

Si raccomanda l'esatta esecuzione della sede  
The valve seat should be perfectly tooled

## ESEMPIO TIPICO DI CIRCUITO / TYPICAL CIRCUIT EXAMPLE

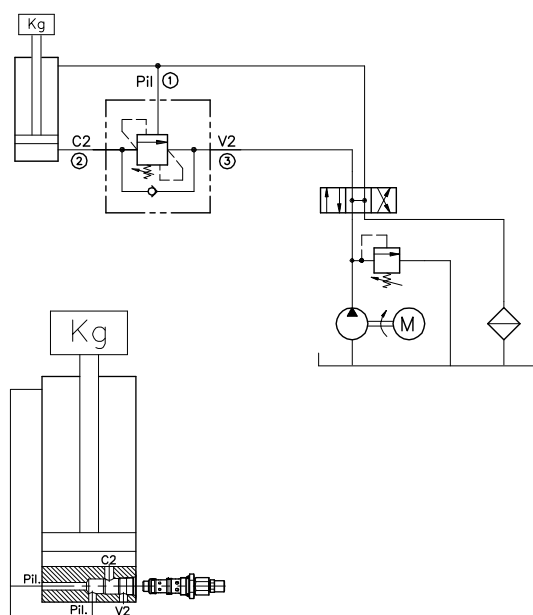

## CODICE DI ORDINAZIONE / HOW TO ORDER

N01.046 . 0 X 0

Campo taratura / Setting range				Rapporto di pilotaggio / Pilot ratios		Regolazione / Adjustment	
046		001		O	4.25 : 1	X	Grano - Dowel
Campo taratura 30÷220 bar (molla colore verde) Setting range 30÷220 bar (green spring)		Campo taratura 60÷350 bar (molla colore giallo) Setting range 60÷350 bar (yellow spring)		D	8 : 1		
Taratura standard (Q=5 l/1')	Incr. press. - bar giro/vite	Taratura standard (Q=5 l/1')	Incr. press. - bar giro/vite				
Std. bar setting (Q=5 l/1')	Pressure rise - turn of screw	Std. bar setting (Q=5 l/1')	Pressure rise - turn of screw				
<b>180 bar</b>	<b>(50)</b>	<b>250 bar</b>	<b>(90)</b>				

# OWC-30-...

VALVOLA BILANCIAMENTO, BLOCCO E CONTROLLO  
MOVIMENTO A CARTUCCIA

CARTRIDGE COUNTERBALANCE VALVES WITH WITHOUT BODY

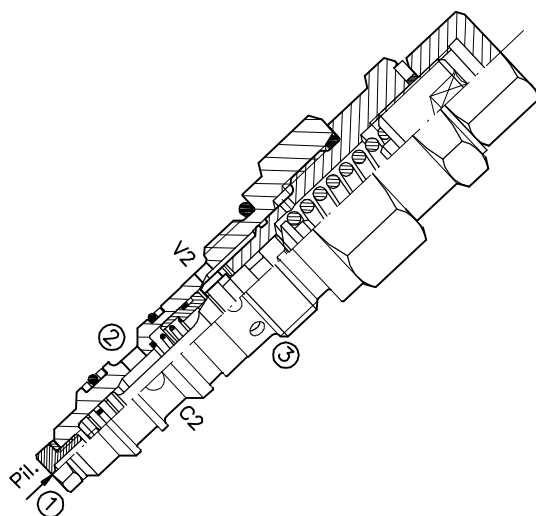
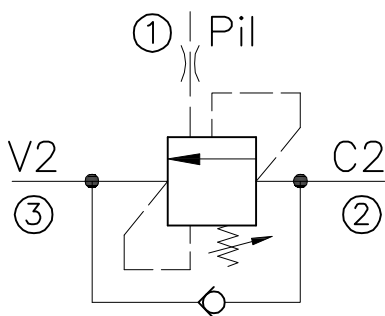

## CARATTERISTICHE

Luce nominale	<b>DN 4</b>
Portata min/max	<b>1/25 l/min - 0.15/6.6 GPM</b>
Pressione max. di picco	<b>450 bar - 6525 PSI</b>
Pressione max. di taratura	<b>350 bar - 5075 PSI</b>
Rapporto di pilotaggio standard	<b>4 : 1</b>
Temperatura ambiente	<b>-30°C + 50°C</b>
Temperatura olio	<b>-30°C + 80°C</b>
Filtraggio consigliato	<b>30 micron</b>
Coppia di serraggio	<b>76÷82 Nm</b>
Peso	<b>0.300 Kg</b>

## PERFORMANCE

Rated size
Min/max flow-rate
Max peak pressure
Max setting pressure
Standard pilot ratio
Room temperature
Oil temperature
Recommended filtration
Tightening torque
Weight

### NOTE:

La taratura deve essere **1.3** volte maggiore della pressione indotta dal carico.

Valve should be set at **1.3** times load induced pressure.

### ESEMPIO/EXAMPLE:

Pressione di lavoro max:

Max working pressure:

**350 bar / 1.3 = 270 bar**

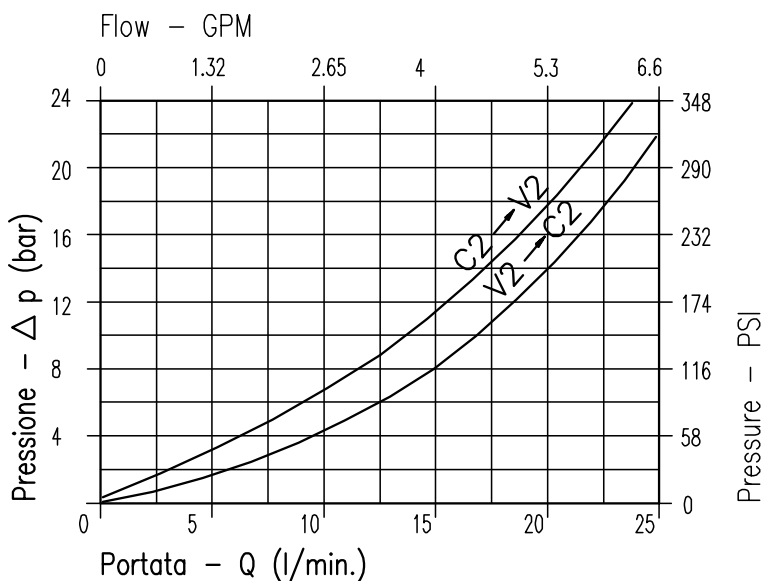

Viscosità olio 46 cSt a 50°C  
Oil viscosity 46 cSt at 50°C

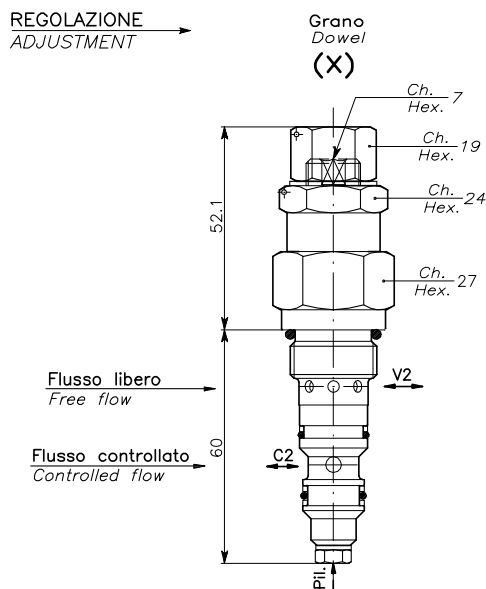

CAVITÀ  
CAVITY

CE.120.N

ESEMPIO TIPICO DI CIRCUITO  
TYPICAL CIRCUIT EXAMPLE

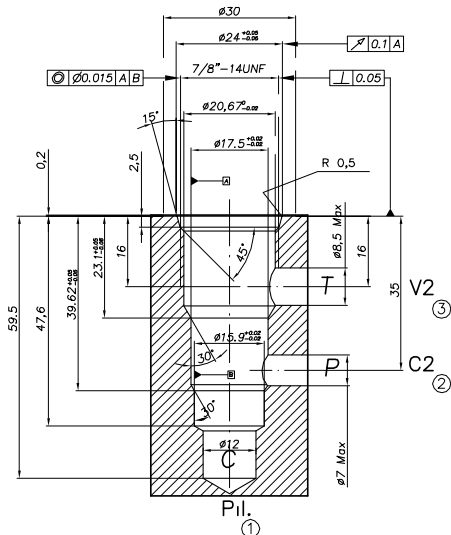

Si raccomanda l'esatta esecuzione della sede  
The valve seat should be perfectly tooled

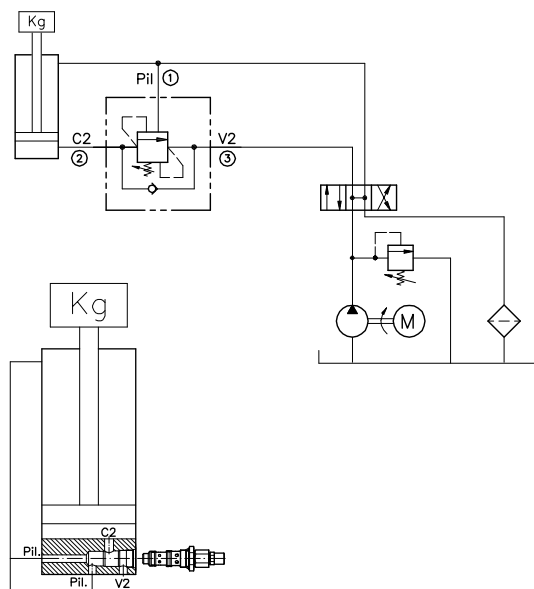

## CODICE DI ORDINAZIONE HOW TO ORDER

001.620 . 0 X 0

Campo taratura / Setting range				Rapporto di pilotaggio Pilot ratios		Regolazione Adjustment	
620		635		O	4 : 1	X	Grano - Dowel
Campo taratura 30÷220 bar (molla colore verde) Setting range 30÷220 bar (green spring)		Campo taratura 60÷350 bar (molla colore giallo) Setting range 60÷350 bar (yellow spring)		F	7 : 1		
Taratura standard (Q=5 l/1')	Incr. press. - bar giro/vite	Taratura standard (Q=5 l/1')	Incr. press. - bar giro/vite				
Std. bar setting (Q=5 l/1')	Pressure rise - turn of screw	Std. bar setting (Q=5 l/1')	Pressure rise - turn of screw				
<b>180 bar</b>	<b>(45)</b>	<b>250 bar</b>	<b>(75)</b>				

# WBC-40-CC-RPV 9-...

VALVOLA BILANCIAMENTO, BLOCCO E CONTROLLO MOVIMENTO PER CENTRO CHIUSO A CARTUCCIA

CARTRIDGE STYLE COUNTERBALANCE VALVE FOR CLOSED CENTRE SPOOL

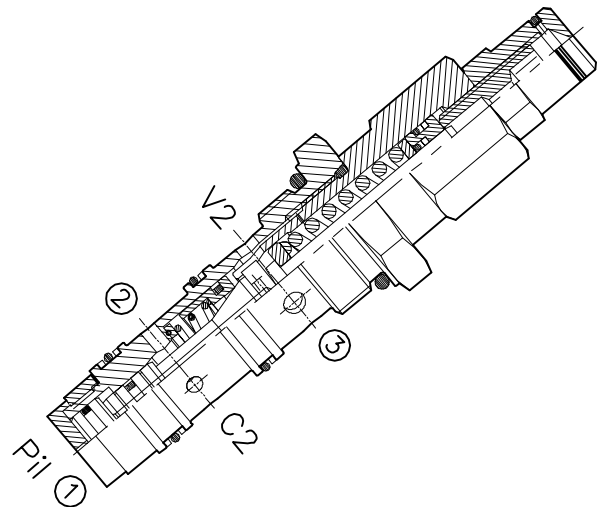
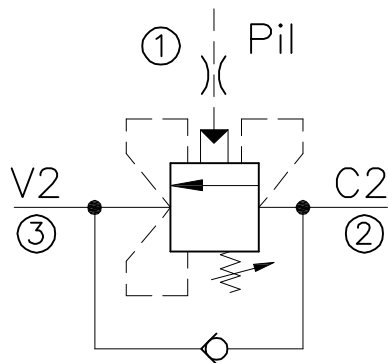

## CARATTERISTICHE

Luce nominale	<b>DN 10</b>
Portata min/max	<b>1/60 l/min - 0.26/15.9 GPM</b>
Pressione max. di picco	<b>450 bar - 6525 PSI</b>
Pressione max. di taratura	<b>350 bar - 5075 PSI</b>
Rapporto di pilotaggio standard	<b>9 : 1</b>
Temperatura ambiente	<b>-30°C + 50°C</b>
Temperatura olio	<b>-30°C + 80°C</b>
Filtraggio consigliato	<b>30 micron</b>
Coppia di serraggio	<b>116÷128 Nm</b>
Peso	<b>0.300 Kg</b>

## PERFORMANCE

Rated size
Min/max flow-rate
Max peak pressure
Max setting pressure
Standard pilot ratio
Room temperature
Oil temperature
Recommended filtration
Tightening torque
Weight

### NOTE:

La taratura deve essere **1.3** volte maggiore della pressione indotta dal carico.

Valve should be set at **1.3** times load induced pressure.

### ESEMPIO/EXAMPLE:

Pressione di lavoro max:  
Max working pressure:  
**350 bar / 1.3 = 270 bar**

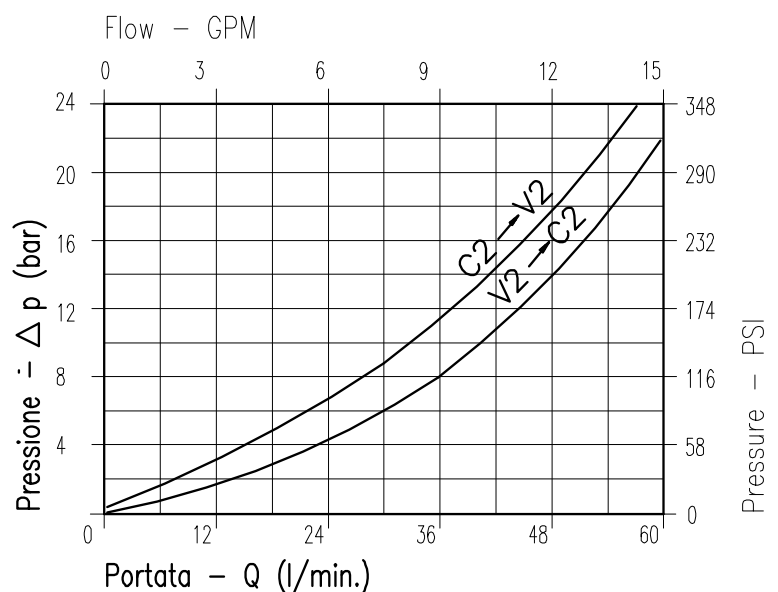

Viscosità olio 46 cSt a 50°C  
Oil viscosity 46 cSt at 50°C

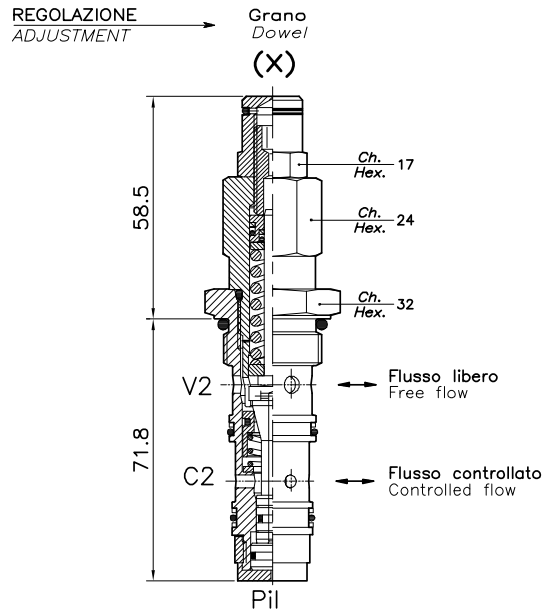

**CAVITÀ  
CAVITY**

**CE.025.N**

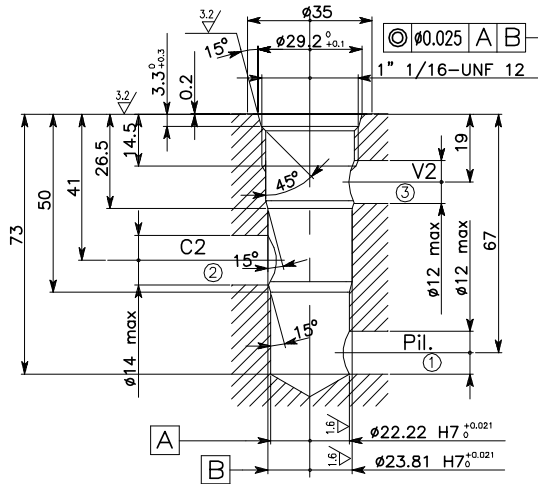

Si raccomanda l'esatta esecuzione della sede  
The valve seat should be perfectly tooled

**ESEMPIO TIPICO DI CIRCUITO  
TYPICAL CIRCUIT EXAMPLE**

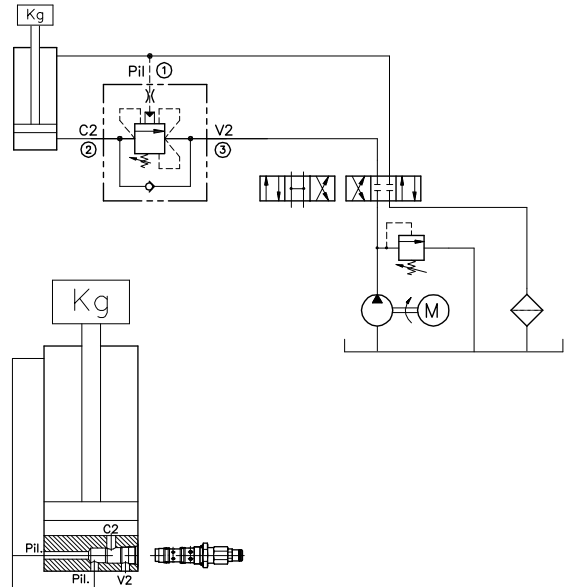

**CODICE DI ORDINAZIONE  
HOW TO ORDER**

001.011 . 0 X 0

Campo taratura / Setting range  
**011**

Campo taratura 60÷350 bar (molla colore rosso)  
Setting range 60÷350 bar (red spring)

Taratura standard (Q=5 l/1')  
Std. bar setting (Q=5 l/1')  
**250 bar**

Incr. press. - bar giro/vite  
Pressure rise - turn of screw  
**(140)**

Rapporto di pilotaggio  
Pilot ratios  
0 | 9 : 1

Regolazione  
Adjustment  
X | Grano - Dowel

# OWC-30-CC-...

VALVOLA BILANCIAMENTO, BLOCCO E CONTROLLO MOVIMENTO PER CENTRO CHIUSO A CARTUCCIA

CARTRIDGE STYLE COUNTERBALANCE VALVE FOR CLOSED CENTRE SPOOL

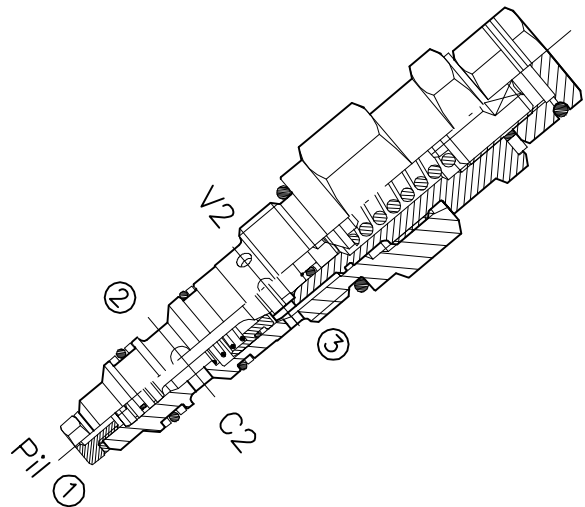
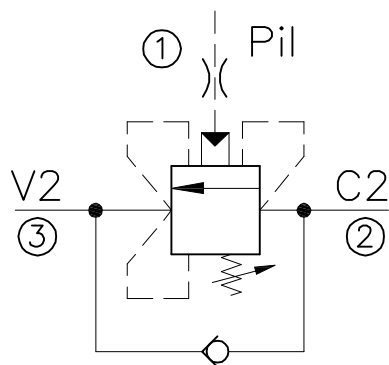

## CARATTERISTICHE

Luce nominale  
 Portata min/max  
 Pressione max. di picco  
 Pressione max. di taratura  
 Rapporto di pilotaggio standard  
 Temperatura ambiente  
 Temperatura olio  
 Filtraggio consigliato  
 Coppia di serraggio  
 Peso

**DN 4**  
**1/25 l/min - 0.26/6.6 GPM**  
**450 bar - 6525 PSI**  
**350 bar - 5075 PSI**  
**4 : 1**  
**-30°C + 50°C**  
**-30°C + 80°C**  
**30 micron**  
**76÷82 Nm**  
**0.300 Kg**

## PERFORMANCE

Rated size  
 Min/max flow-rate  
 Max peak pressure  
 Max setting pressure  
 Standard pilot ratio  
 Room temperature  
 Oil temperature  
 Recommended filtration  
 Tightening torque  
 Weight

### NOTE:

La taratura deve essere **1.3** volte maggiore della pressione indotta dal carico.

Valve should be set at **1.3** times load induced pressure.

### ESEMPIO/EXAMPLE:

Pressione di lavoro max:  
 Max working pressure:  
**350 bar / 1.3 = 270 bar**

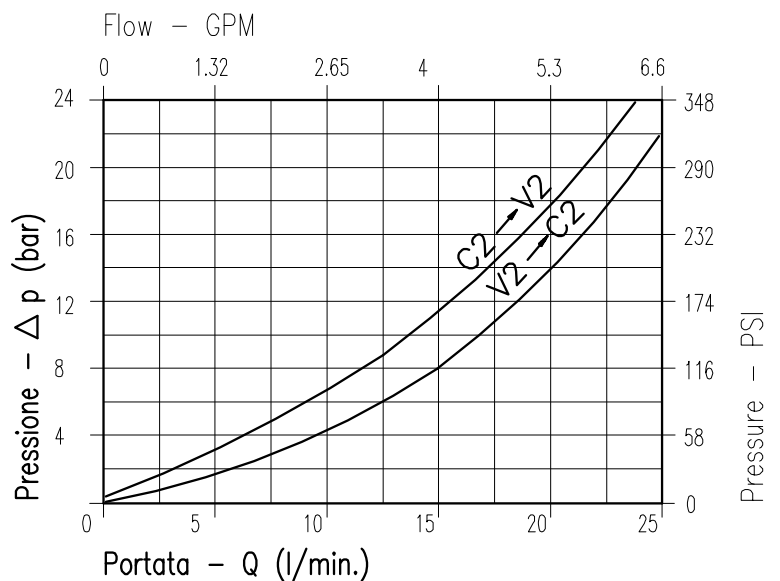

Viscosità olio 46 cSt a 50°C  
 Oil viscosity 46 cSt at 50°C

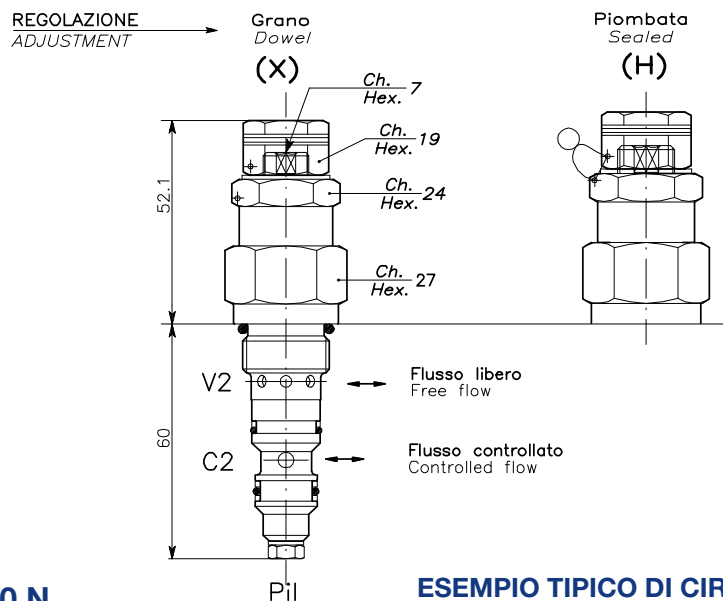

CAVITÀ  
CAVITY

CE.120.N

ESEMPIO TIPICO DI CIRCUITO  
TYPICAL CIRCUIT EXAMPLE

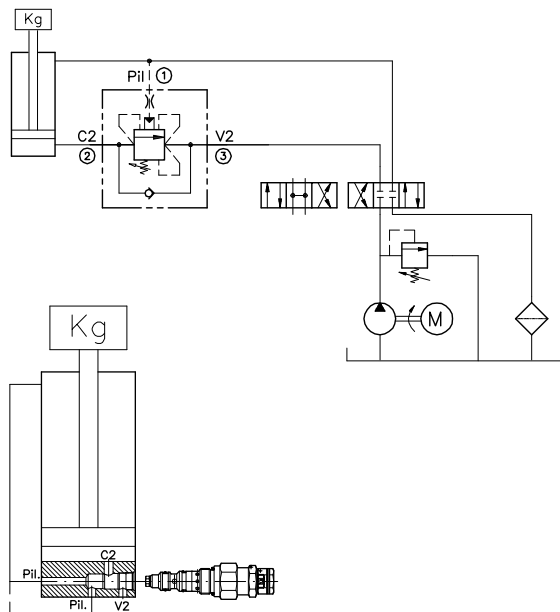
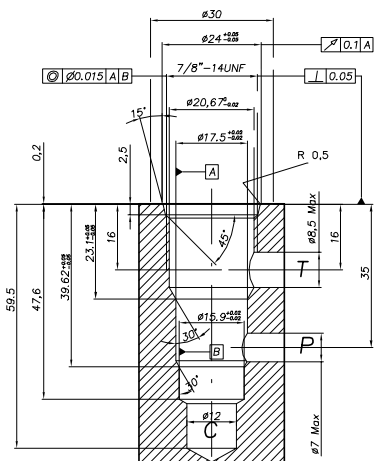

Si raccomanda l'esatta esecuzione della sede  
The valve seat should be perfectly tooled

CODICE DI ORDINAZIONE  
HOW TO ORDER

001.621 . 0 X 0

Campo taratura / Setting range				Rapporto di pilotaggio Pilot ratios		Regolazione Adjustment	
621		636		O	4 : 1	X	Grano - Dowel
Campo taratura 30÷220 bar (molla colore verde) Setting range 30÷220 bar (green spring)		Campo taratura 60÷350 bar (molla colore giallo) Setting range 60÷350 bar (yellow spring)		F	7 : 1	H	Piombata - Sealed
Taratura standard (Q=5 l/1')	Incr. press. - bar giro/vite	Taratura standard (Q=5 l/1')	Incr. press. - bar giro/vite				
Std. bar setting (Q=5 l/1')	Pressure rise - turn of screw	Std. bar setting (Q=5 l/1')	Pressure rise - turn of screw				
<b>180 bar</b>	<b>(45)</b>	<b>250 bar</b>	<b>(75)</b>				

# WBC-40-CC-...

VALVOLA BILANCIAMENTO, BLOCCO E CONTROLLO MOVIMENTO PER CENTRO CHIUSO A CARTUCCIA

CARTRIDGE STYLE COUNTERBALANCE VALVE FOR CLOSED CENTRE SPOOL

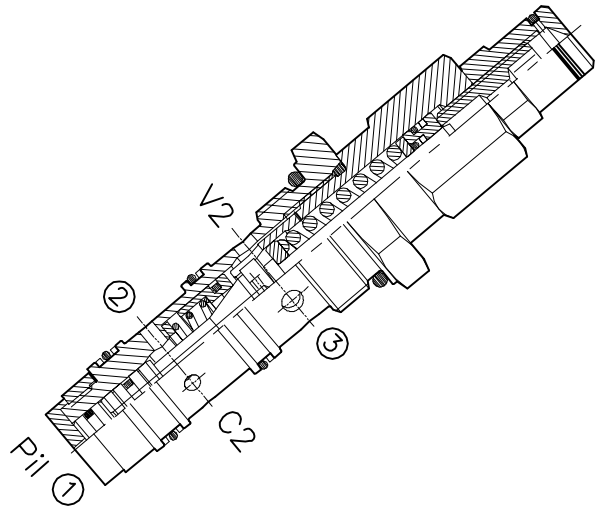
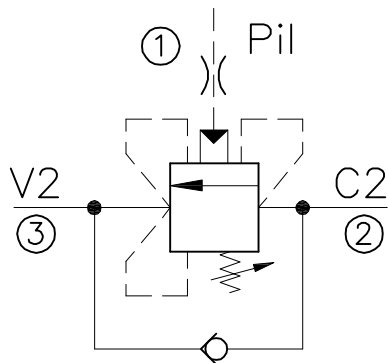

## CARATTERISTICHE

Luce nominale	<b>DN 10</b>
Portata min/max	<b>1/60 l/min - 0.26/15.9 GPM</b>
Pressione max. di picco	<b>450 bar - 6525 PSI</b>
Pressione max. di taratura	<b>350 bar - 5075 PSI</b>
Rapporto di pilotaggio standard	<b>4.25 : 1</b>
Temperatura ambiente	<b>-30°C + 50°C</b>
Temperatura olio	<b>-30°C + 80°C</b>
Filtraggio consigliato	<b>30 micron</b>
Coppia di serraggio	<b>76÷82 Nm</b>
Peso	<b>0.300 Kg</b>

## PERFORMANCE

Rated size
Min/max flow-rate
Max peak pressure
Max setting pressure
Standard pilot ratio
Room temperature
Oil temperature
Recommended filtration
Tightening torque
Weight

### NOTE:

La taratura deve essere **1.3** volte maggiore della pressione indotta dal carico.

Valve should be set at **1.3** times load induced pressure.

### ESEMPIO/EXAMPLE:

Pressione di lavoro max:

Max working pressure:

**350 bar / 1.3 = 270 bar**

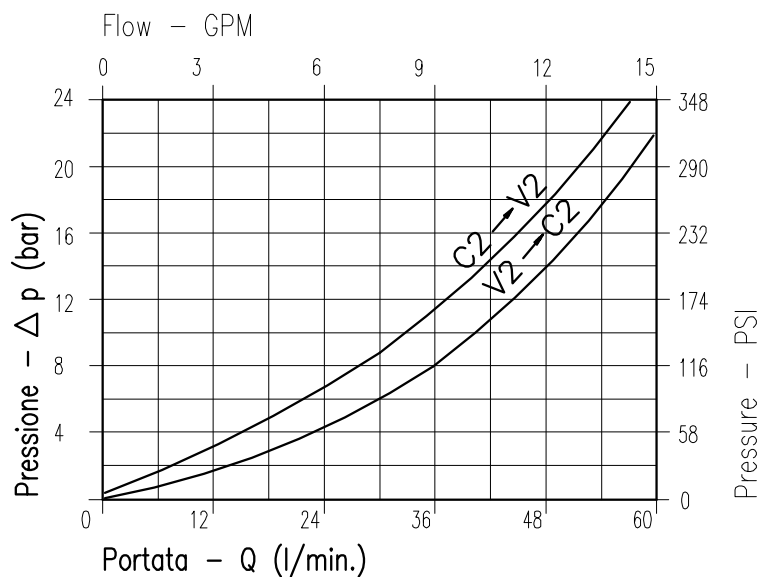

Viscosità olio 46 cSt a 50°C  
Oil viscosity 46 cSt at 50°C



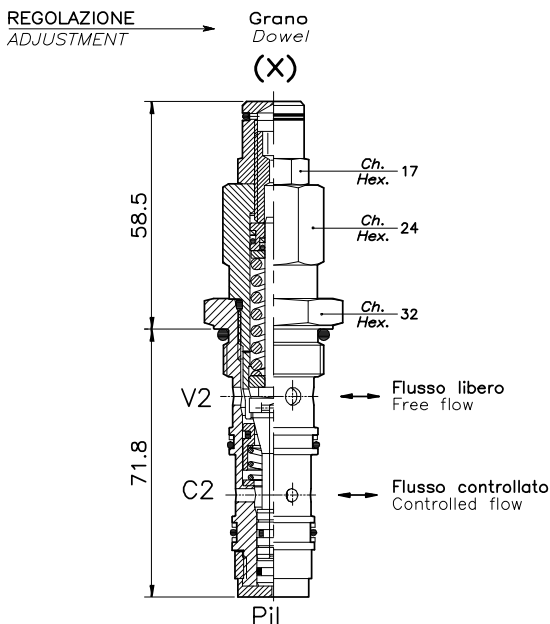

**CAVITÀ  
CAVITY**

**CE.025.N**

**ESEMPIO TIPICO DI CIRCUITO  
TYPICAL CIRCUIT EXAMPLE**

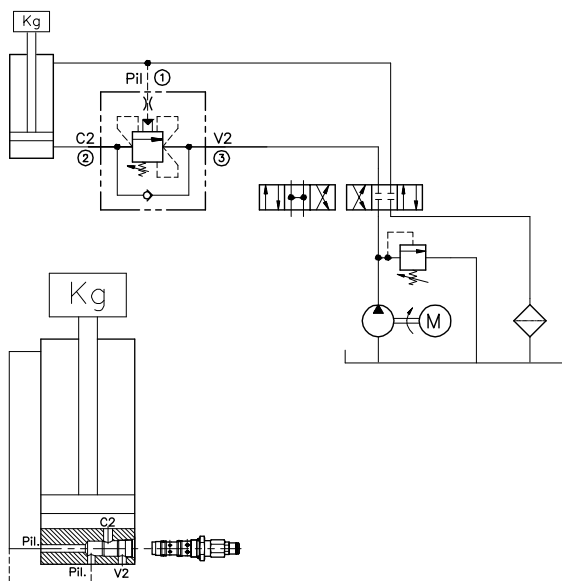
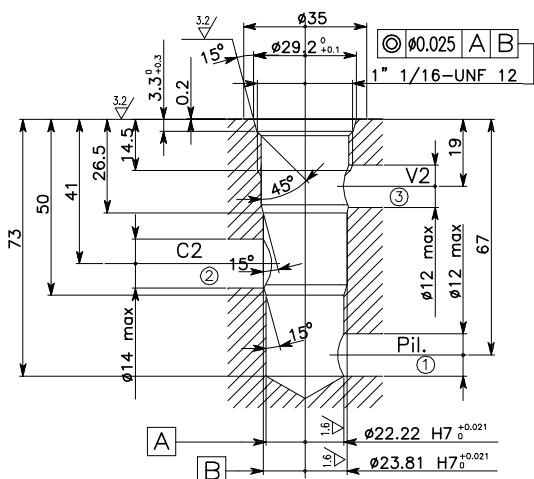

Si raccomanda l'esatta esecuzione della sede  
The valve seat should be perfectly tooled

**CODICE DI ORDINAZIONE  
HOW TO ORDER**

001 . 498 . 0 X 0

Campo taratura / Setting range

498

Campo taratura 60÷350 bar (molla colore rosso)  
Setting range 60÷350 bar (red spring)

Taratura standard (Q=5 l/1')  
Std. bar setting (Q=5 l/1')  
**250 bar**

Incr. press. - bar giro/vite  
Pressure rise - turn of screw  
**(140)**

Rapporto di pilotaggio  
Pilot ratios

O 4.25 : 1  
D 8 : 1

Regolazione  
Adjustment

X Grano - Dowel

# A-OWC-SE-...-L-FR

VALVOLA BILANCIAMENTO, BLOCCO E CONTROLLO MOVIMENTO A SEMPLICE EFFETTO CON COLLETTORE IN LINEA

SINGLE COUNTERBALANCE VALVE WITH IN LINE BODY

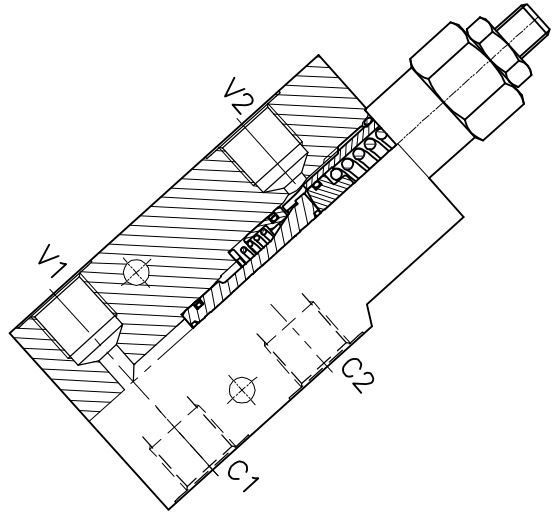
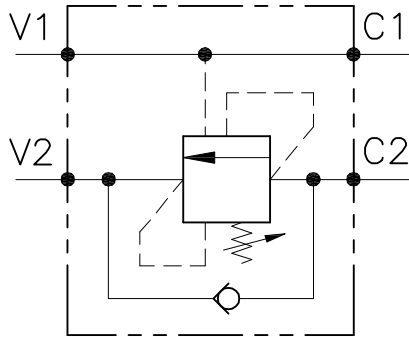

## CARATTERISTICHE

Luce nominale	<b>DN 6/8/10</b>
Portata min/max	<b>1/60 l/min - 0.26/15.9 GPM</b>
Pressione max. di picco	<b>450 bar - 6525 PSI</b>
Pressione max. di taratura	<b>350 bar - 5075 PSI</b>
Rapporto di pilotaggio standard	<b>4.25 : 1</b>
Temperatura ambiente	<b>-30°C + 50°C</b>
Temperatura olio	<b>-30°C + 80°C</b>
Filtraggio consigliato	<b>30 micron</b>
Coppia di serraggio	
Peso	

## PERFORMANCE

Rated size
Min/max flow-rate
Max peak pressure
Max setting pressure
Standard pilot ratio
Room temperature
Oil temperature
Recommended filtration
Tightening torque
Weight

### NOTE:

La taratura deve essere 1.3 volte maggiore della pressione indotta dal carico. Valve should be set at 1.3 times load induced pressure.

### ESEMPIO/EXAMPLE:

Pressione di lavoro max **350 bar / 1.3 = 270 bar** Max working pressure  
 Fornitura standard valvola: corpo in acciaio. A richiesta corpo in alluminio. Steel body valves as standard, aluminium body on request

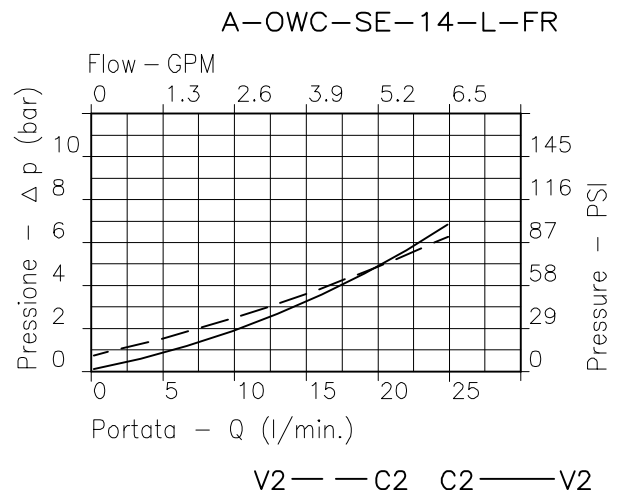
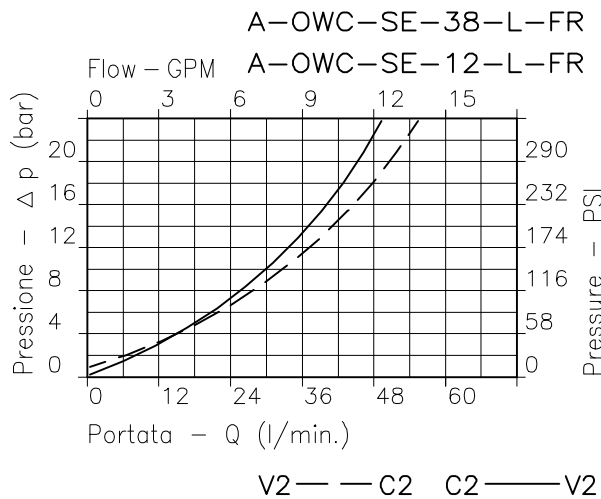

Viscosità olio 46 cSt a 50°C - Oil viscosity 46 cSt at 50°C

REGOLAZIONE  
ADJUSTMENT

Grano  
Dowel  
(X)

Piombata  
Sealed  
(K)

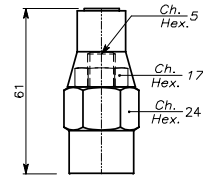
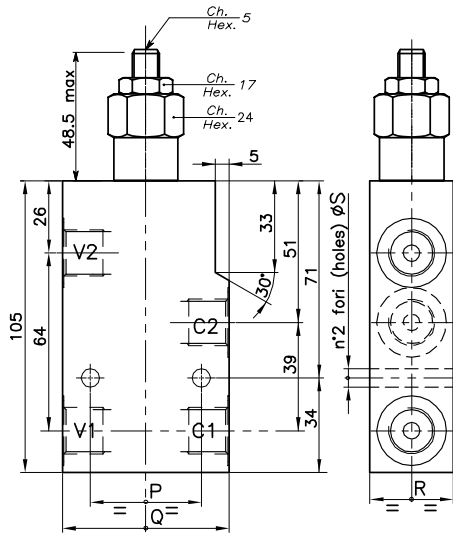

## ESEMPIO TIPICO DI CIRCUITO TYPICAL CIRCUIT EXAMPLE

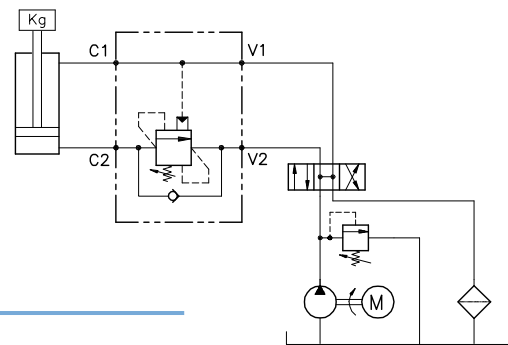

## DIMENSIONI DIMENSIONS

Campo taratura Setting range	P	Q	R	S	Attacchi Port size V2-C2 V1-C1 GAS (BSPP)	Luce nominale Rated size DN	Portata max Max flow-rate l/min - GPM
085   084	40	60	30	6.5	1/4"	6	20-5
087   086	40	60	30	6.5	3/8"	8	40-10
093   088	50	70	35	8.5	1/2"	10	60-15

## CODICE DI ORDINAZIONE HOW TO ORDER

N01 . 085 . 0 X 0 . A

Campo taratura / Setting range	
085	084
087	086
093	088
Campo taratura 30÷220 bar (molla colore verde)	Campo taratura 60÷350 bar (molla colore giallo)
Setting range 30÷220 bar (green spring)	Setting range 60÷350 bar (yellow spring)
Taratura standard (Q=5 l/1')	Taratura standard (Q=5 l/1')
Incr. press. - bar giro/vite	Incr. press. - bar giro/vite
Std. bar setting (Q=5 l/1')	Std. bar setting (Q=5 l/1')
<b>180 bar</b>	<b>250 bar</b>
(50)	(90)

Rapporto di pilotaggio  
Pilot ratios

O	4.25 : 1
D	8 : 1

Regolazione  
Adjustment

X	Grano - Dowel
K	Piombata - Sealed

Collettore  
Body

A	Acciaio zincato Zinc plated steel
---	--------------------------------------

# A-WB-C-SE-...-L-...-...

VALVOLA BILANCIAMENTO, BLOCCO E CONTROLLO MOVIMENTO A SEMPLICE EFFETTO CON COLLETTORE IN LINEA

SINGLE COUNTERBALANCE VALVE WITH IN LINE BODY

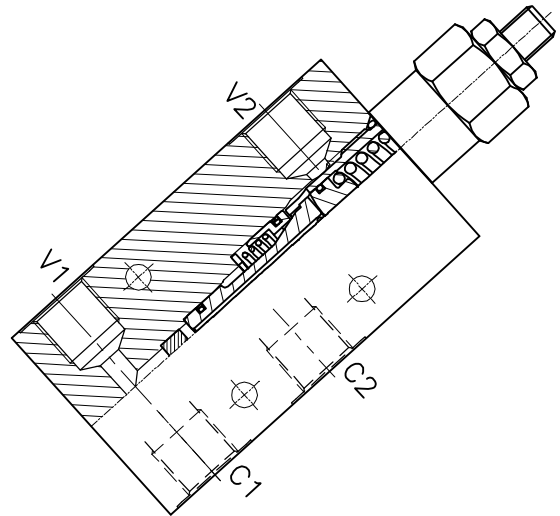
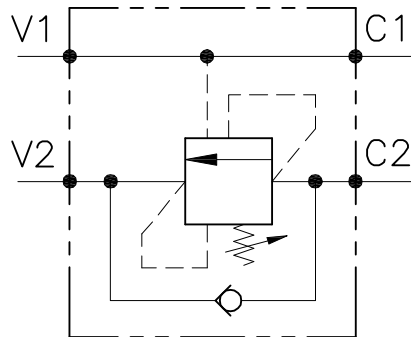

## CARATTERISTICHE

Luce nominale	<b>DN 6/8/10</b>
Portata min/max	<b>1/60 l/min - 0.26/15.9 GPM</b>
Pressione max. di picco	<b>450 bar - 6525 PSI</b>
Pressione max. di taratura	<b>350 bar - 5075 PSI</b>
Rapporto di pilotaggio standard	<b>4.25 : 1</b>
Temperatura ambiente	<b>-30°C + 50°C</b>
Temperatura olio	<b>-30°C + 80°C</b>
Filtraggio consigliato	<b>30 micron</b>
Coppia di serraggio	
Peso	

## PERFORMANCE

Rated size
Min/max flow-rate
Max peak pressure
Max setting pressure
Standard pilot ratio
Room temperature
Oil temperature
Recommended filtration
Tightening torque
Weight

### NOTE:

La taratura deve essere 1.3 volte maggiore della pressione indotta dal carico. Valve should be set at 1.3 times load induced pressure.

### ESEMPIO/EXAMPLE:

Pressione di lavoro max **350 bar / 1.3 = 270 bar** Max working pressure  
 Fornitura standard valvola: corpo in acciaio. A richiesta corpo in alluminio. Steel body valves as standard, aluminium body on request

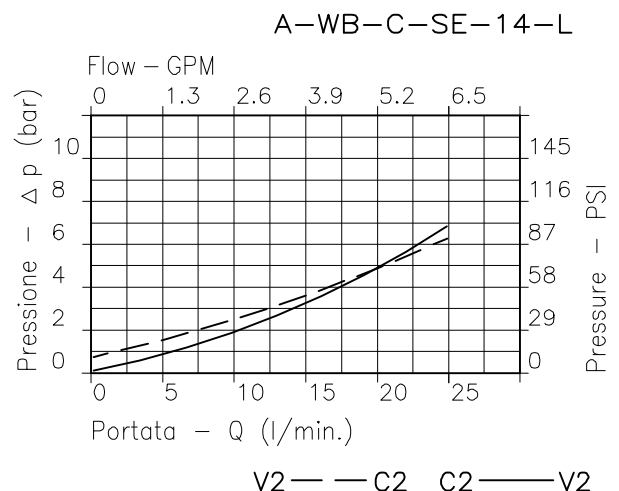
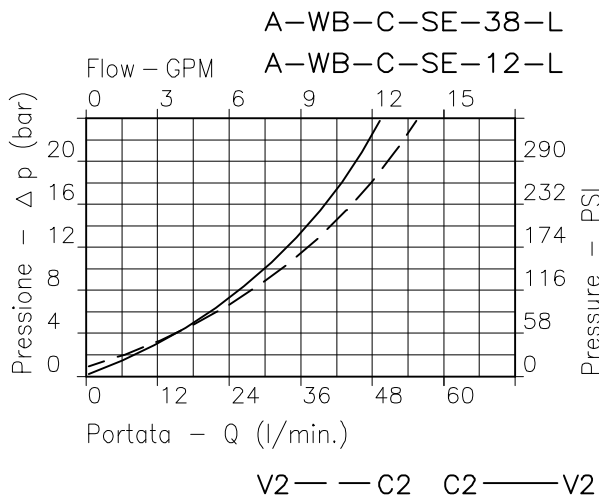

Viscosità olio 46 cSt a 50°C - Oil viscosity 46 cSt at 50°C

REGOLAZIONE  
ADJUSTMENT →

Grano  
Dowel  
(X)

Piombata  
Sealed  
(K)

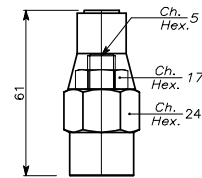
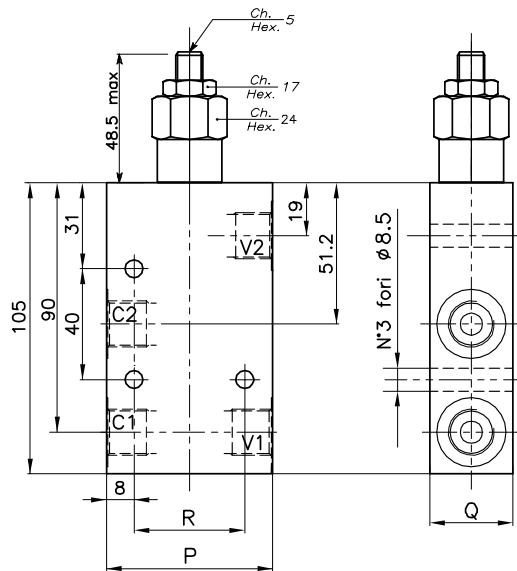

## ESEMPIO TIPICO DI CIRCUITO TYPICAL CIRCUIT EXAMPLE

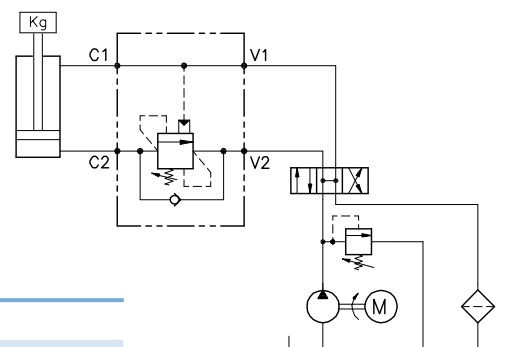

## DIMENSIONI DIMENSIONS

Campo taratura Setting range		P	Q	R	Attacchi Port size V2-C2 V1-C1 GAS (BSPP)	Luce nominale Rated size DN	Portata max Max flow-rate l/min - GPM
328	327	60	30	40	3/8"	8	40-10
330	329	70	35	50	1/2"	10	60-15

## CODICE DI ORDINAZIONE HOW TO ORDER

N01 . 328 . 0 X 0 . A

Campo taratura / Setting range			
328		327	
330		329	
Campo taratura 30÷220 bar (molla colore verde) Setting range 30÷220 bar (green spring)		Campo taratura 60÷350 bar (molla colore giallo) Setting range 60÷350 bar (yellow spring)	
Taratura standard (Q=5 l/1')	Incr. press. - bar giro/vite	Taratura standard (Q=5 l/1')	Incr. press. - bar giro/vite
Std. bar setting (Q=5 l/1')	Pressure rise - turn of screw	Std. bar setting (Q=5 l/1')	Pressure rise - turn of screw
<b>180 bar</b>	<b>(50)</b>	<b>250 bar</b>	<b>(90)</b>

Rapporto di pilotaggio Pilot ratios	
O	4.25 : 1
D	8 : 1

Regolazione Adjustment	
X	Grano - Dowel
K	Piombata - Sealed

Collettore Body	
A	Acciaio zincato Zinc plated steel

327	
328	Collettore possibile in AL togliendo "A"
329	Available aluminium body without "A"
330	

# ...-OWC-SE-...-L-...

VALVOLA BILANCIAMENTO, BLOCCO E CONTROLLO MOVIMENTO A SEMPLICE EFFETTO CON COLLETTORE IN LINEA

SINGLE COUNTERBALANCE VALVE WITH IN LINE BODY

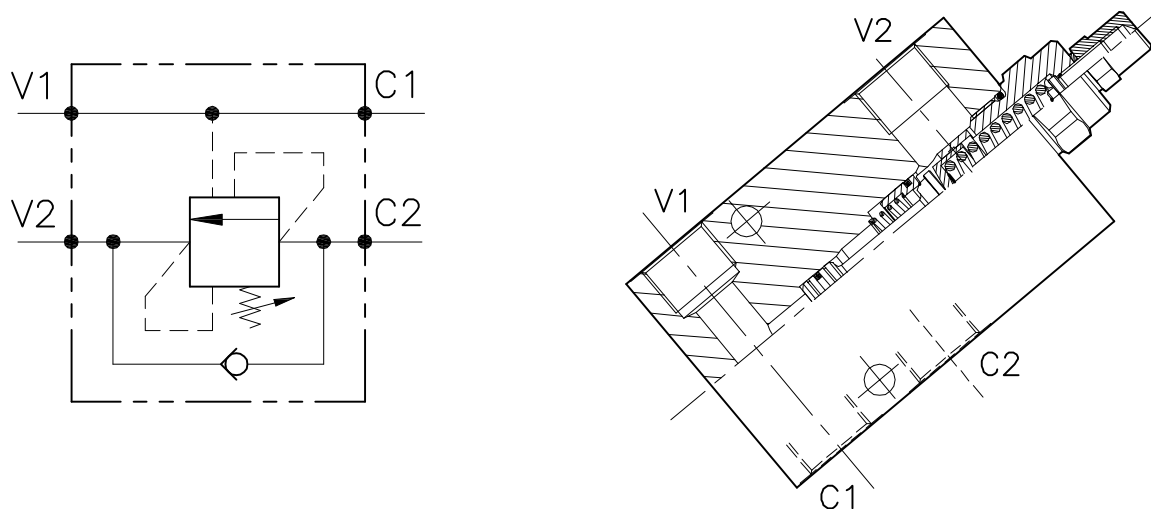

## CARATTERISTICHE

Luce nominale	<b>DN 12/14</b>
Portata min/max	<b>1/160 l/min - 0.26/42.3 GPM</b>
Pressione max. di picco	<b>450 bar - 6525 PSI</b>
Pressione max. di taratura	<b>350 bar - 5075 PSI</b>
Rapporto di pilotaggio standard	<b>6.2 : 1</b>
Temperatura ambiente	<b>-30°C + 50°C</b>
Temperatura olio	<b>-30°C + 80°C</b>
Filtraggio consigliato	<b>30÷50</b>
Coppia di serraggio	
Peso	

## PERFORMANCE

Rated size
Min/max flow-rate
Max peak pressure
Max setting pressure
Standard pilot ratio
Room temperature
Oil temperature
Recommended filtration
Tightening torque
Weight

### NOTE:

La taratura deve essere **1.3** volte maggiore della pressione indotta dal carico.

Valve should be set at **1.3** times load induced pressure.

### ESEMPIO/EXAMPLE:

Pressione di lavoro max:

Max working pressure:

**350 bar / 1.3 = 270 bar**

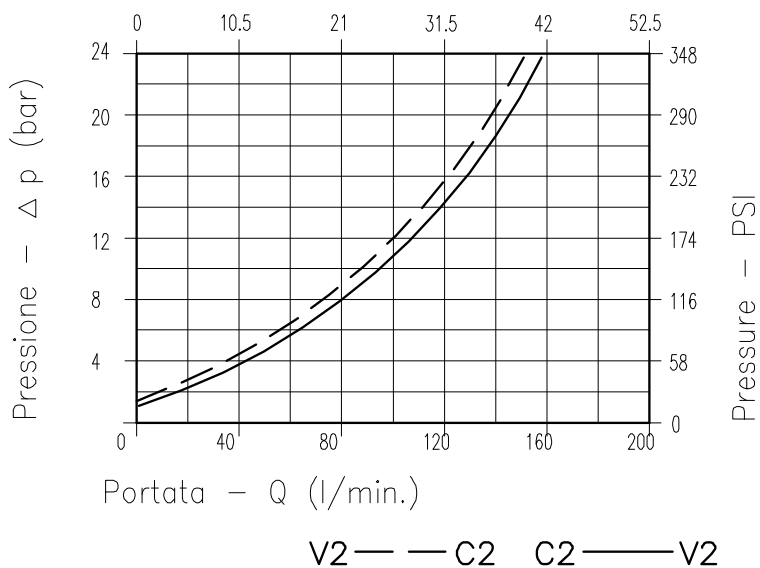

**Viscosità olio 46 cSt a 50°C**  
**Oil viscosity 46 cSt at 50°C**

REGOLAZIONE  
ADJUSTMENT →

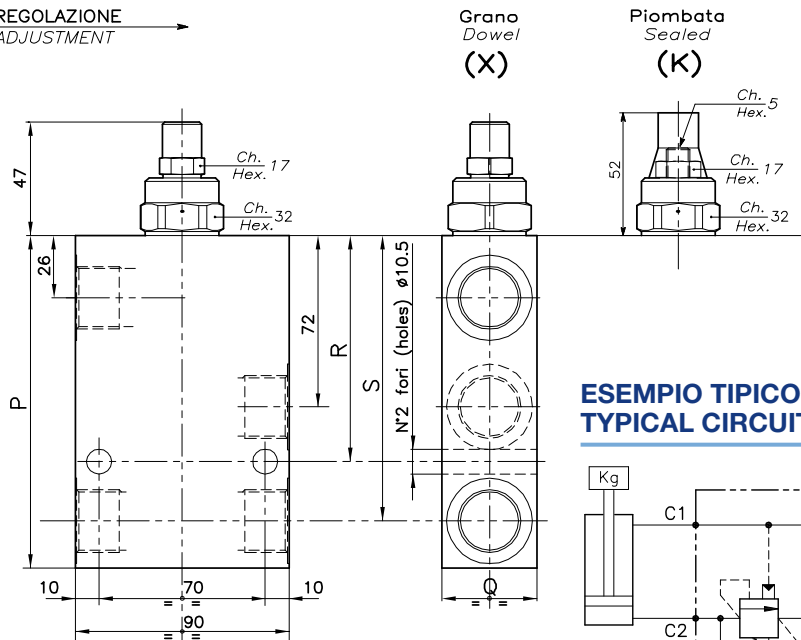

## ESEMPIO TIPICO DI CIRCUITO TYPICAL CIRCUIT EXAMPLE

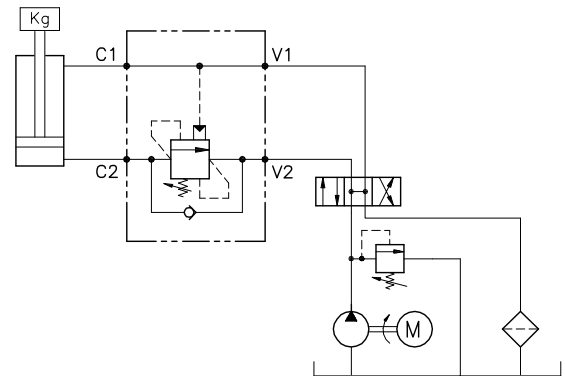

## DIMENSIONI DIMENSIONS

Campo taratura Setting range	P	Q	R	S	Attacchi Port size V2-C2 V1-C1 GAS (BSPP)	Luce nominale Rated size	Portata max Max flow-rate	Corpo Body
265	140	40	95	120	3/4"	DN 12	120-31 l/min - GPM	Acciaio Steel
266	165	50	107	142	1"	DN 14	160-42 l/min - GPM	Acciaio Steel

## CODICE DI ORDINAZIONE HOW TO ORDER

001 . 265 . 0 X 0 . A

Campo taratura / Setting range	Rapporto di pilotaggio Pilot ratios	Regolazione Adjustment	Collettore Body
265	O 6.2 : 1	X Grano - Dowel	A Acciaio zincato Zinc plated steel
266	G 4.1 : 1	K Piombata - Sealed	
Campo taratura 60÷350 bar (molla colore giallo) Setting range 60÷350 bar (yellow spring)			
Taratura standard (Q=5 l/1') Std. bar setting Q=5 l/1')			
<b>250 bar</b>			
Incr. press. - bar giro/vite Pressure rise - turn of screw			
<b>(125)</b>			

# OWC-30-SE-14-L

VALVOLA BILANCIAMENTO, BLOCCO E CONTROLLO MOVIMENTO A SEMPLICE EFFETTO CON COLLETTORE IN LINEA

SINGLE COUNTERBALANCE VALVE WITH IN LINE BODY

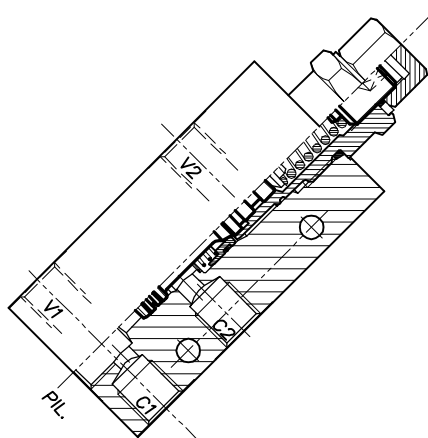
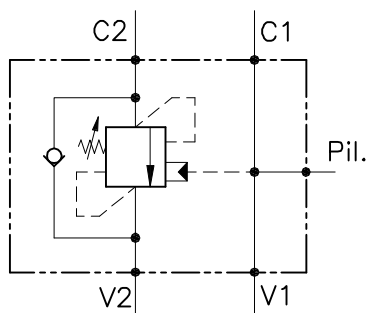

## CARATTERISTICHE

Luce nominale	<b>DN 6</b>
Portata min/max	<b>1/25 l/min - 0.26/6.6 GPM</b>
Pressione max. di picco	<b>450 bar - 6525 PSI</b>
Pressione max. di taratura	<b>350 bar - 5075 PSI</b>
Rapporto di pilotaggio standard	<b>4 : 1</b>
Temperatura ambiente	<b>-30°C + 50°C</b>
Temperatura olio	<b>-30°C + 80°C</b>
Filtraggio consigliato	<b>30 micron</b>
Coppia di serraggio	
Peso	<b>0.300 Kg</b>

## PERFORMANCE

Rated size
Min/max flow-rate
Max peak pressure
Max setting pressure
Standard pilot ratio
Room temperature
Oil temperature
Recommended filtration
Tightening torque
Weight

### NOTE:

La taratura deve essere **1.3** volte maggiore della pressione indotta dal carico.

Valve should be set at **1.3** times load induced pressure.

### ESEMPIO/EXAMPLE:

Pressione di lavoro max:

Max working pressure:

**350 bar / 1.3 = 270 bar**

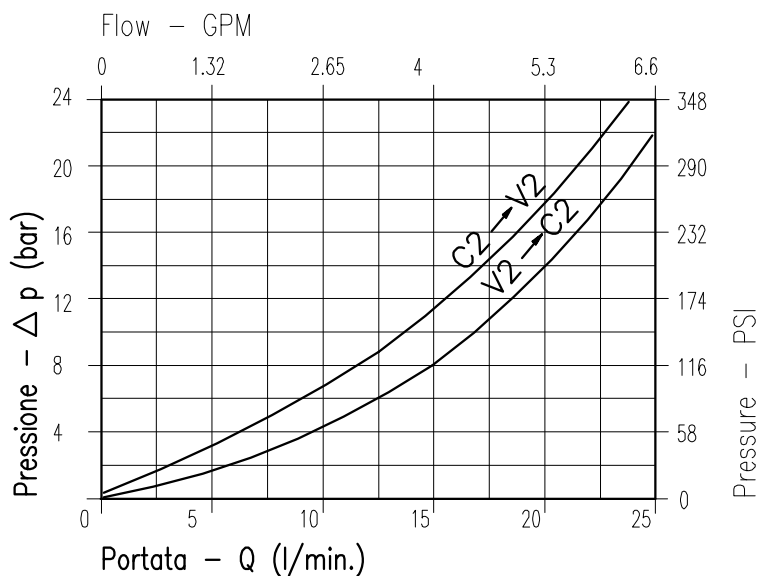

Viscosità olio 46 cSt a 50°C  
Oil viscosity 46 cSt at 50°C



REGOLAZIONE  
ADJUSTMENT →

Grano  
Dowel  
(X)

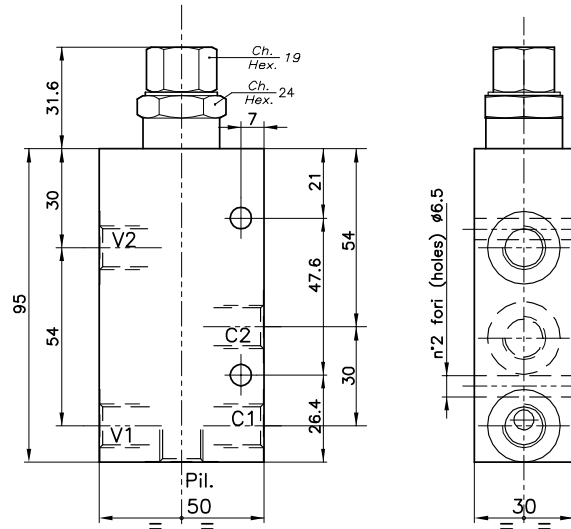

## DIMENSIONI DIMENSIONS

Campo taratura Setting range	Attacchi Port size V2-C2 V1-C1-PIL GAS (BSPP)	Luce nominale Rated size	Portata max Max flow-rate
623	1/4"	DN 6	l/min - GPM 25-6

## ESEMPIO TIPICO DI CIRCUITO TYPICAL CIRCUIT EXAMPLE

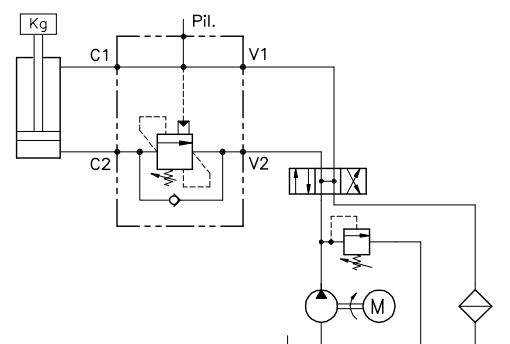

## CODICE DI ORDINAZIONE HOW TO ORDER

001 . 623 . 0 X 0 . A

Campo taratura / Setting range

623

Campo taratura 60÷350 bar (molla colore giallo)  
Setting range 60÷350 bar (yellow spring)

Taratura standard (Q=5 l/1')  
Std. bar setting Q=5 l/1')

250 bar

Incr. press. - bar giro/vite  
Pressure rise - turn of screw  
(75)

Rapporto  
di pilotaggio  
Pilot ratios

O	4 : 1
F	7 : 1

Regolazione  
Adjustment

X	Grano - Dowel
---	---------------

Collettore  
Body

A	Acciaio zincato Zinc plated steel
---	--

# A-WB-C-SE-...-14-...-...

VALVOLA BILANCIAMENTO, BLOCCO E CONTROLLO MOVIMENTO CON PILOTAGGIO ESTERNO

COUNTERBALANCE VALVE WITH EXTERNAL PILOT

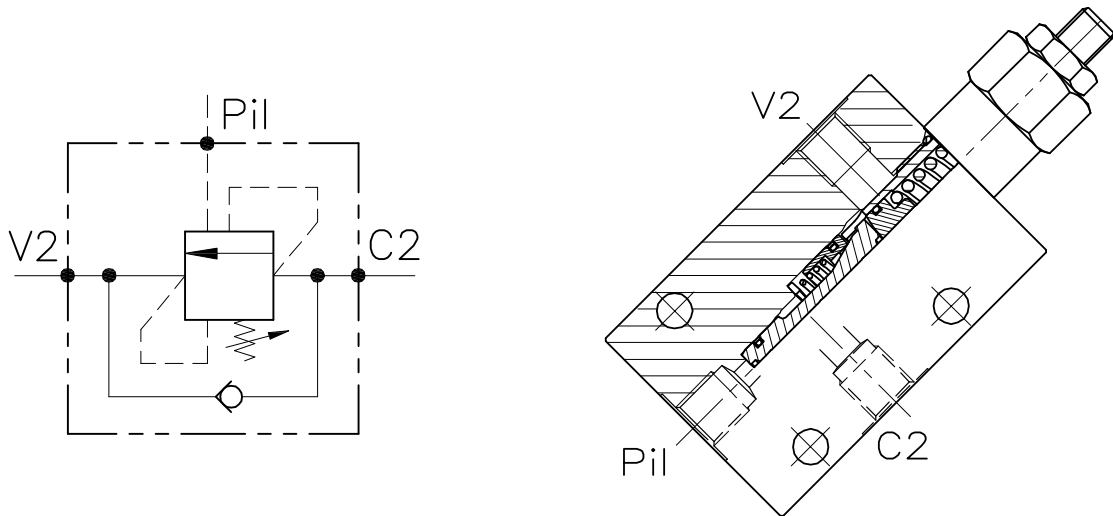

## CARATTERISTICHE

Luce nominale	<b>DN 6/8/10</b>
Portata min/max	<b>1/60 l/min - 0.26/15.9 GPM</b>
Pressione max. di picco	<b>450 bar - 6525 PSI</b>
Pressione max. di taratura	<b>350 bar - 5075 PSI</b>
Rapporto di pilotaggio standard	<b>4.25 : 1</b>
Temperatura ambiente	<b>-30°C + 50°C</b>
Temperatura olio	<b>-30°C + 80°C</b>
Filtraggio consigliato	<b>30 micron</b>
Coppia di serraggio	
Peso	

## PERFORMANCE

Rated size
Min/max flow-rate
Max peak pressure
Max setting pressure
Standard pilot ratio
Room temperature
Oil temperature
Recommended filtration
Tightening torque
Weight

### NOTE:

La taratura deve essere 1.3 volte maggiore della pressione indotta dal carico. Valve should be set at 1.3 times load induced pressure.

### ESEMPIO/EXAMPLE:

Pressione di lavoro max **350 bar / 1.3 = 270 bar** Max working pressure  
 Fornitura standard valvola: corpo in acciaio. A richiesta corpo in alluminio. Steel body valves as standard, aluminium body on request

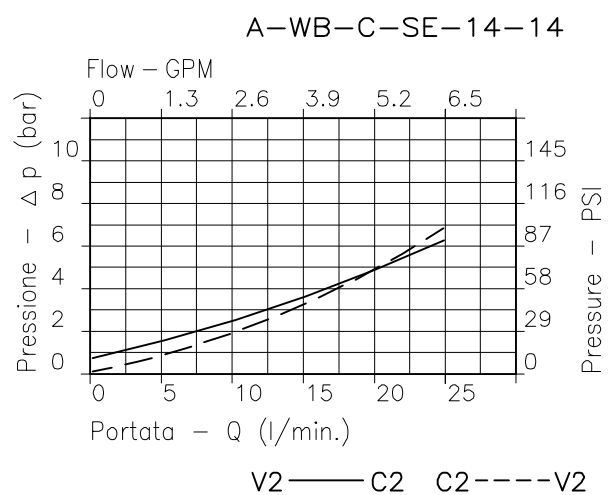
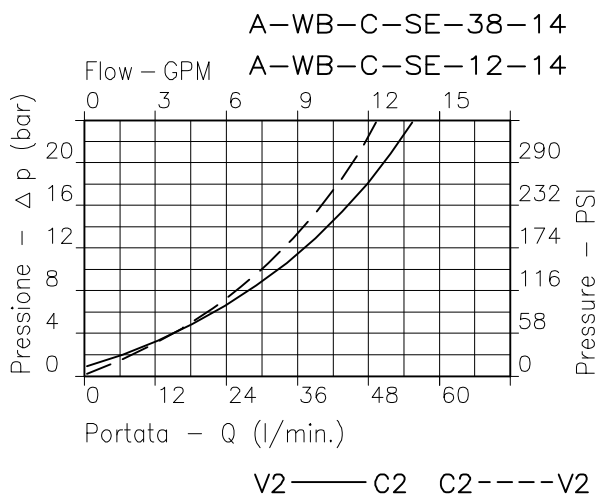

Viscosità olio 46 cSt a 50°C - Oil viscosity 46 cSt at 50°C

REGOLAZIONE  
ADJUSTMENT →

Grano  
Dowel  
(X)

Piombata  
Sealed  
(K)

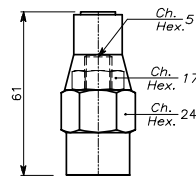
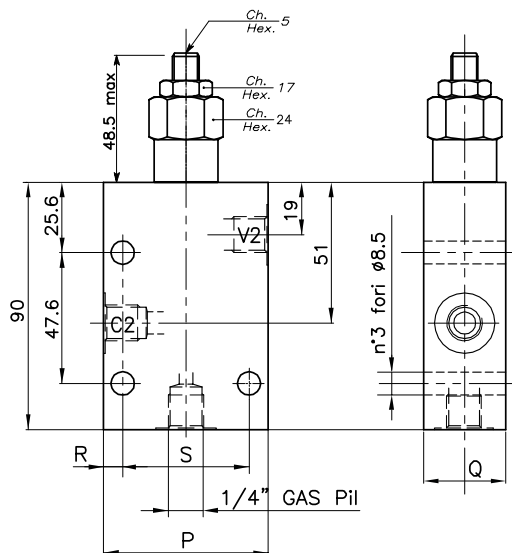

## ESEMPIO TIPICO DI CIRCUITO TYPICAL CIRCUIT EXAMPLE

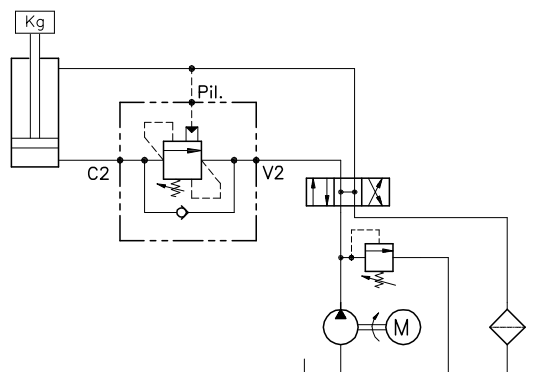

## DIMENSIONI DIMENSIONS

Campo taratura Setting range		P	Q	R	S	Attacchi Port size V2-C2 GAS (BSPP)	Luce nominale Rated size DN	Portata max Max flow-rate l/min - GPM
239	238	60	30	10	40	3/8"	8	40-10
241	240	70	35	10	50	1/2"	10	60-15

## CODICE DI ORDINAZIONE HOW TO ORDER

N01 . 239 . 0 X 0 . A

Campo taratura / Setting range				Rapporto di pilotaggio Pilot ratios	Regolazione Adjustment	Collettore Body
239	238	0	X	0	A	
241	240					
Campo taratura 30÷220 bar (molla colore verde) Setting range 30÷220 bar (green spring)		Campo taratura 60÷350 bar (molla colore giallo) Setting range 60÷350 bar (yellow spring)		O 4.25 : 1 D 8 : 1	X Grano - Dowel K Piombata - Sealed	A Acciaio zincato Zinc plated steel
Taratura standard (Q=5 l/1')	Incr. press. - bar giro/vite	Taratura standard (Q=5 l/1')	Incr. press. - bar giro/vite			
Std. bar setting (Q=5 l/1')	Pressure rise - turn of screw	Std. bar setting (Q=5 l/1')	Pressure rise - turn of screw			
<b>180 bar</b>	<b>(50)</b>	<b>250 bar</b>	<b>(90)</b>			

# ...-OWC-SE-...-14

VALVOLA BILANCIAMENTO, BLOCCO E CONTROLLO MOVIMENTO CON PILOTAGGIO ESTERNO

COUNTERBALANCE VALVE WITH EXTERNAL PILOT

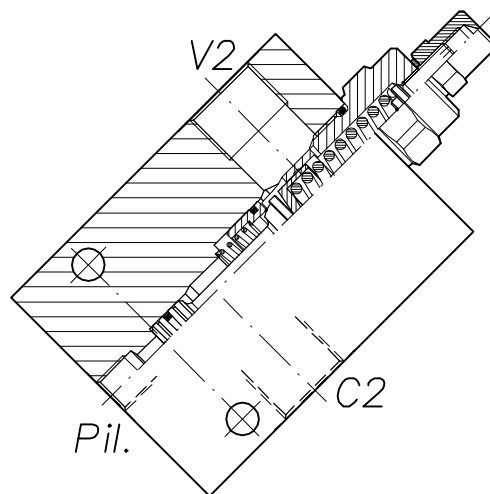
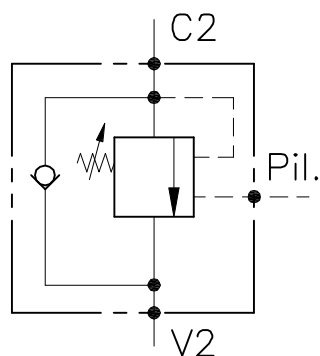

## CARATTERISTICHE

Luce nominale  
 Portata min/max  
 Pressione max. di picco  
 Pressione max. di taratura  
 Rapporto di pilotaggio standard  
 Temperatura ambiente  
 Temperatura olio  
 Filtraggio consigliato  
 Coppia di serraggio  
 Peso

**DN 12/14**  
**1/160 l/min - 0.26/42.3 GPM**  
**450 bar - 6525 PSI**  
**350 bar - 5075 PSI**  
**6.2 : 1**  
**-30°C + 50°C**  
**-30°C + 80°C**  
**30÷50 micron**

## PERFORMANCE

Rated size  
 Min/max flow-rate  
 Max peak pressure  
 Max setting pressure  
 Standard pilot ratio  
 Room temperature  
 Oil temperature  
 Recommended filtration  
 Tightening torque  
 Weight

### NOTE:

La taratura deve essere **1.3** volte maggiore della pressione indotta dal carico.

Valve should be set at **1.3** times load induced pressure.

### ESEMPIO/EXAMPLE:

Pressione di lavoro max:

Max working pressure:

**350 bar / 1.3 = 270 bar**

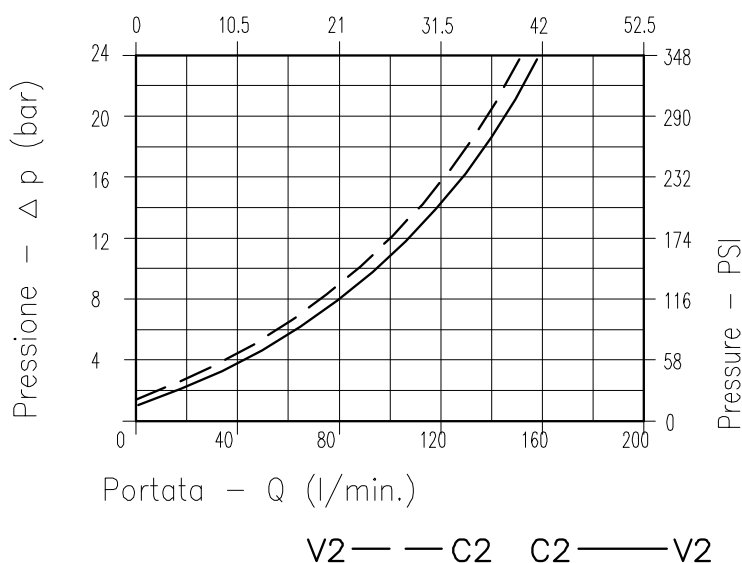

Viscosità olio 46 cSt a 50°C  
 Oil viscosity 46 cSt at 50°C

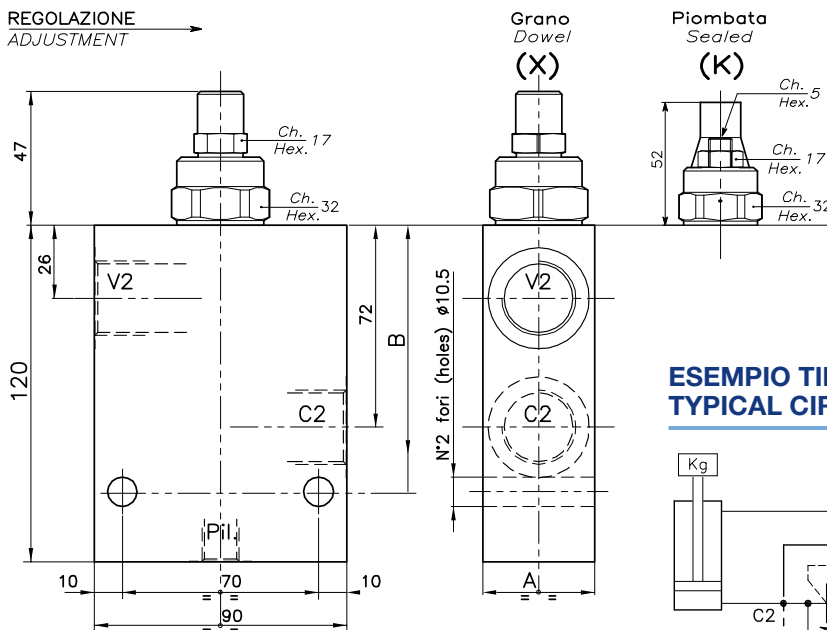

## ESEMPIO TIPICO DI CIRCUITO TYPICAL CIRCUIT EXAMPLE

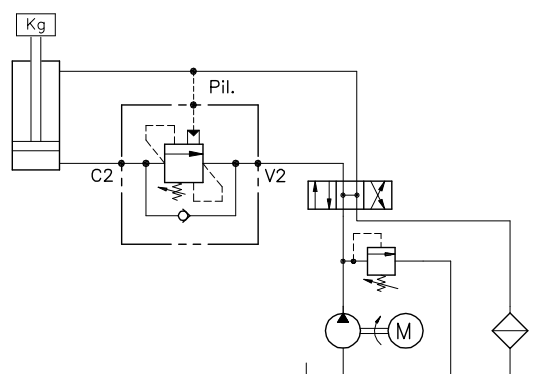

## DIMENSIONI DIMENSIONS

Campo taratura Setting range	Corpo Body	A	B	Attacchi Port size V2-C2 GAS (BSP)	Luce nominale Rated size DN	Portata max Max flow-rate l/min - GPM	Attacchi Port size PIL
448	Acciaio Steel	95	120	3/4"	12	120-31	1/4"
450	Acciaio Steel	107	142	1"	14	160-42	1/4"

## CODICE DI ORDINAZIONE HOW TO ORDER

001 . 448 . 0 X 0 . A

Campo taratura / Setting range

448

450

Campo taratura 60÷350 bar (molla colore verde)  
Setting range 60÷350 bar (greenspring)

Taratura standard (Q=5 l/1')  
Std. bar setting Q=5 l/1')

250 bar

Incr. press. - bar giro/vite  
Pressure rise - turn of screw  
(125)

Rapporto di pilotaggio  
Pilot ratios

O 6.2 : 1  
G 4 : 1

Regolazione  
Adjustment

X Grano - Dowel  
K Piombata - Sealed

Collettore  
Body

A Acciaio  
zincato  
Zinc plated  
steel

448

Collettore possibile in AL togliendo "A"  
Available aluminium body without "A"

# A-WB-CC-SE-...-L-...

VALVOLA BILANCIAMENTO, BLOCCO E CONTROLLO MOVIMENTO PER CENTRO CHIUSO CON COLLETTORE IN LINEA  
COUNTERBALANCE VALVE FOR CLOSED CENTRE SPOOL WITH IN LINE BODY

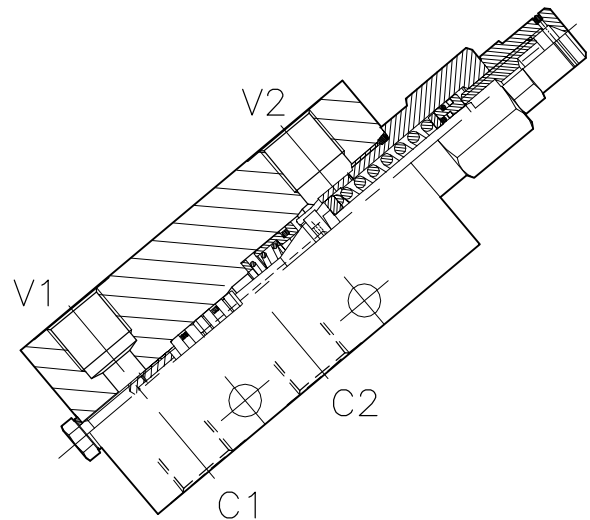
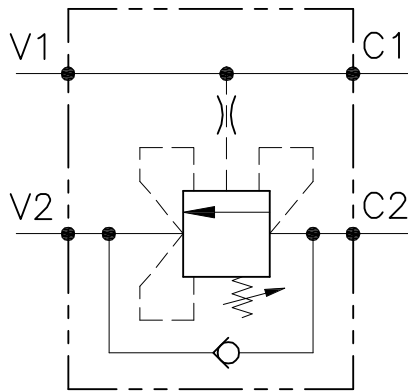

## CARATTERISTICHE

Luce nominale	<b>DN 6/8/10</b>
Portata min/max	<b>1/60 l/min - 0.26/15.9 GPM</b>
Pressione max. di picco	<b>450 bar - 6525 PSI</b>
Pressione max. di taratura	<b>350 bar - 5075 PSI</b>
Rapporto di pilotaggio standard	<b>4.25 : 1</b>
Temperatura ambiente	<b>-30°C + 50°C</b>
Temperatura olio	<b>-30°C + 80°C</b>
Filtraggio consigliato	<b>30 micron</b>
Coppia di serraggio	
Peso	

## PERFORMANCE

Rated size
Min/max flow-rate
Max peak pressure
Max setting pressure
Standard pilot ratio
Room temperature
Oil temperature
Recommended filtration
Tightening torque
Weight

### NOTE:

La taratura deve essere 1.3 volte maggiore della pressione indotta dal carico. Valve should be set at 1.3 times load induced pressure.

### ESEMPIO/EXAMPLE:

Pressione di lavoro max **350 bar / 1.3 = 270 bar** Max working pressure  
Fornitura standard valvola: corpo in acciaio. A richiesta corpo in alluminio. Steel body valves as standard, aluminium body on request

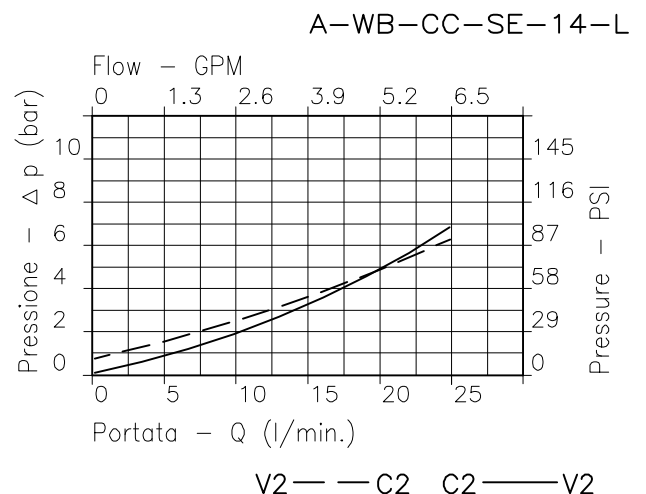
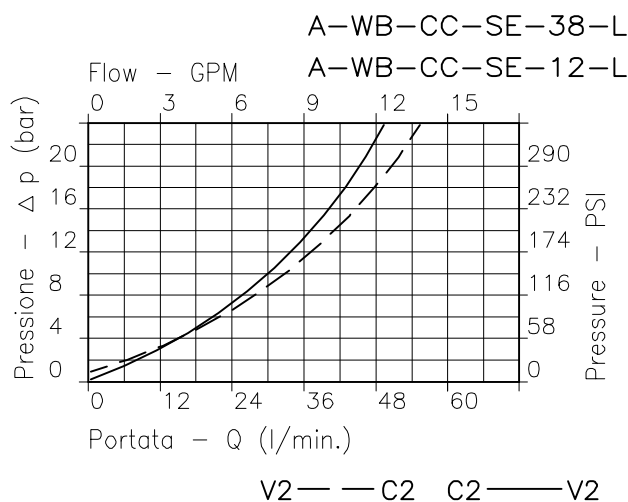

Viscosità olio 46 cSt a 50°C - Oil viscosity 46 cSt at 50°C

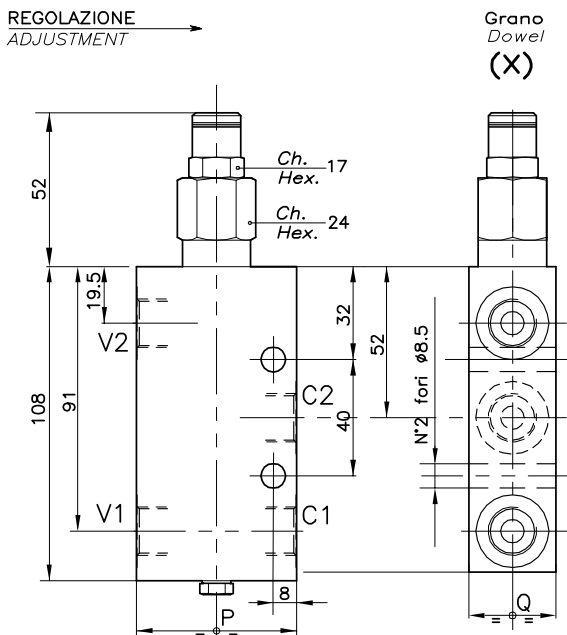

### ESEMPIO TIPICO DI CIRCUITO TYPICAL CIRCUIT EXAMPLE

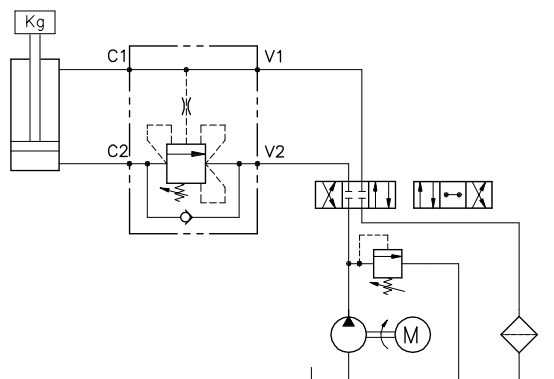

### DIMENSIONI DIMENSIONS

Campo taratura Setting range		P	Q	Attacchi Port size V1-C1 V2-C2 GAS (BSPP)	Luce nominale Rated size DN	Portata max Max flow-rate l/min - GPM
446	477	55	30	3/8"	8	40-10
455	456	65	35	1/2"	10	60-15

### CODICE DI ORDINAZIONE HOW TO ORDER

001 . 446 . 0 X 0 . A

Campo taratura / Setting range			
446		447	
455		456	
Campo taratura 30÷220 bar (molla colore giallo) Setting range 30÷220 bar (green spring)		Campo taratura 60÷350 bar (molla colore rosso) Setting range 60÷350 bar (red spring)	
Taratura standard (Q=5 l/1')	Incr. press. - bar giro/vite Pressure rise - turn of screw	Taratura standard (Q=5 l/1')	Incr. press. - bar giro/vite Pressure rise - turn of screw
Std. bar setting (Q=5 l/1')	(60)	Std. bar setting (Q=5 l/1')	(140)
180 bar		250 bar	

Rapporto di pilotaggio  
Pilot ratios

O 4.25 : 1  
D 8 : 1

Regolazione  
Adjustment

X Grano - Dowel

Collettore  
Body

A Acciaio zincato  
Zinc plated steel

# OWC-SE-...-L-CC-..

VALVOLA BILANCIAMENTO, BLOCCO E CONTROLLO MOVIMENTO PER CENTRO CHIUSO CON COLLETTORE IN LINEA

COUNTERBALANCE VALVE FOR CLOSED CENTRE SPOOL WITH IN LINE BODY

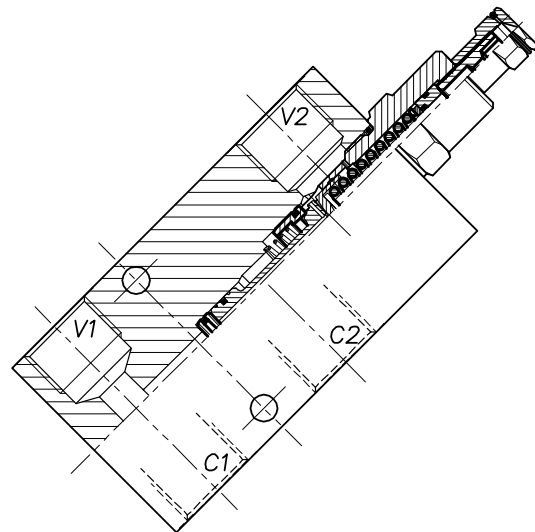
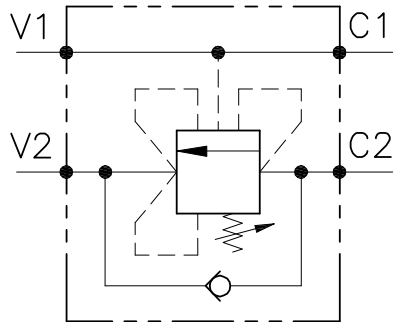

## CARATTERISTICHE

Luce nominale	<b>DN 12/14</b>
Portata min/max	<b>1/160 l/min - 0.26/42.3 GPM</b>
Pressione max. di picco	<b>450 bar - 6525 PSI</b>
Pressione max. di taratura	<b>350 bar - 5075 PSI</b>
Rapporto di pilotaggio standard	<b>6.2 : 1</b>
Temperatura ambiente	<b>-30°C + 50°C</b>
Temperatura olio	<b>-30°C + 80°C</b>
Filtraggio consigliato	<b>30÷50 micron</b>
Coppia di serraggio	
Peso	

## PERFORMANCE

Rated size
Min/max flow-rate
Max peak pressure
Max setting pressure
Standard pilot ratio
Room temperature
Oil temperature
Recommended filtration
Tightening torque
Weight

### NOTE:

La taratura deve essere **1.3** volte maggiore della pressione indotta dal carico.

Valve should be set at **1.3** times load induced pressure.

### ESEMPIO/EXAMPLE:

Pressione di lavoro max:  
Max working pressure:  
**350 bar / 1.3 = 270 bar**

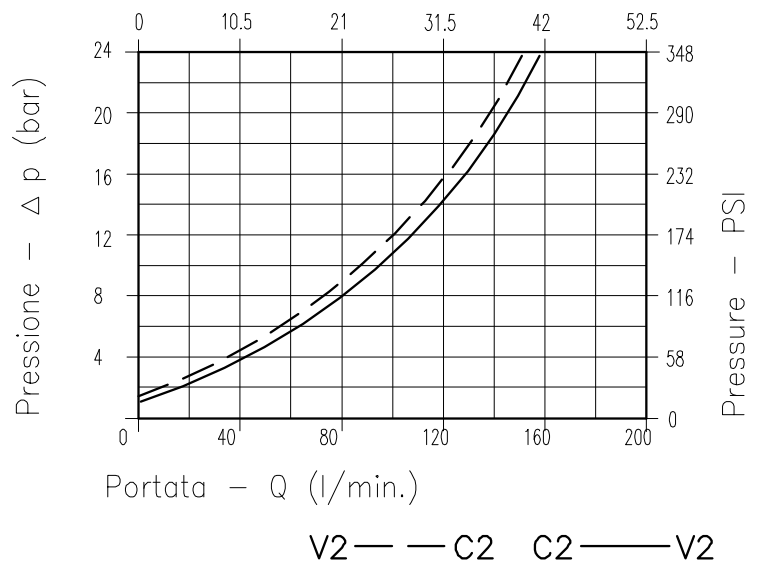

Viscosità olio 46 cSt a 50°C  
Oil viscosity 46 cSt at 50°C



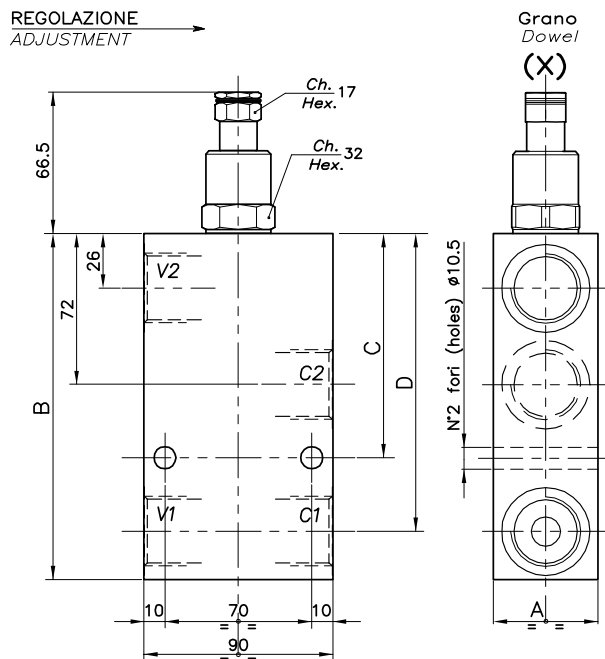

## ESEMPIO TIPICO DI CIRCUITO TYPICAL CIRCUIT EXAMPLE

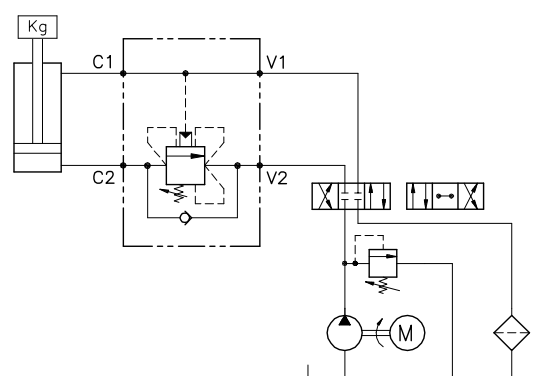

## DIMENSIONI DIMENSIONS

Campo taratura Setting range	A	B	C	D	Attacchi Port size	Luce nominale Rated size	Portata max Max flow-rate
					V2-C2 GAS (BSPP)	DN	l/min - GPM
468	40	140	95	120	3/4"	12	120-31
469	50	165	107	142	1"	14	160-42

## CODICE DI ORDINAZIONE HOW TO ORDER

001 . 468 . 0 X 0 . A

Campo taratura / Setting range

468

469

Campo taratura 60÷350 bar (molla colore giallo)  
Setting range 60÷350 bar (yellow spring)

Taratura standard (Q=5 l/1')  
Std. bar setting Q=5 l/1')

250 bar

Incr. press. - bar giro/vite  
Pressure rise - turn of screw  
(140)

Rapporto  
di pilotaggio  
Pilot ratios

O 6.2 : 1  
G 4.1 : 1

Regolazione  
Adjustment

X Grano - Dowel

Collettore  
Body

A Acciaio  
zincato  
Zinc plated  
steel

# OWC-30-CC-SE-14-L

VALVOLA BILANCIAMENTO, BLOCCO E CONTROLLO MOVIMENTO PER CENTRO CHIUSO CON COLLETTORE IN LINEA

COUNTERBALANCE VALVE FOR CLOSED CENTRE SPOOL WITH IN LINE BODY

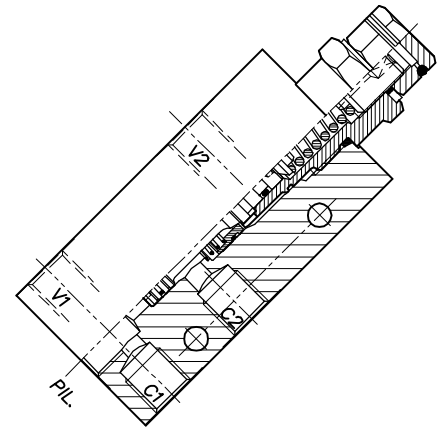
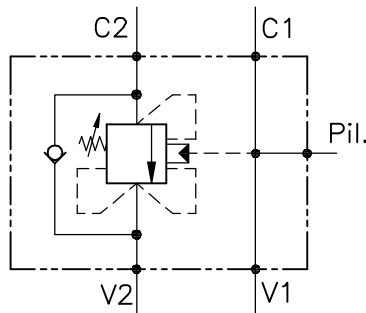

## CARATTERISTICHE

Luce nominale	<b>DN 6</b>
Portata min/max	<b>1/25 l/min - 0.26/6.6 GPM</b>
Pressione max. di picco	<b>450 bar - 6525 PSI</b>
Pressione max. di taratura	<b>350 bar - 5075 PSI</b>
Rapporto di pilotaggio standard	<b>4 : 1</b>
Temperatura ambiente	<b>-30°C + 50°C</b>
Temperatura olio	<b>-30°C + 80°C</b>
Filtraggio consigliato	<b>30 micron</b>
Coppia di serraggio	
Peso	

## PERFORMANCE

Rated size
Min/max flow-rate
Max peak pressure
Max setting pressure
Standard pilot ratio
Room temperature
Oil temperature
Recommended filtration
Tightening torque
Weight

### NOTE:

La taratura deve essere **1.3** volte maggiore della pressione indotta dal carico.

Valve should be set at **1.3** times load induced pressure.

### ESEMPIO/EXAMPLE:

Pressione di lavoro max:

Max working pressure:

**350 bar / 1.3 = 270 bar**

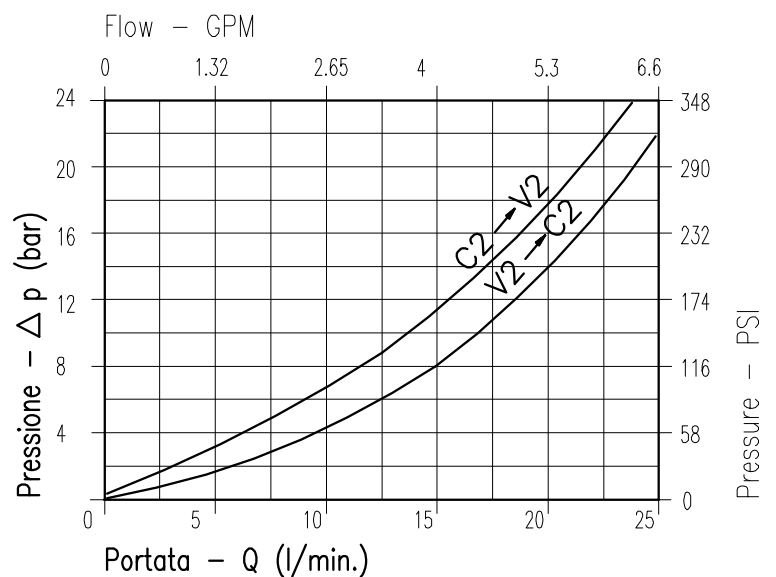

Viscosità olio 46 cSt a 50°C  
Oil viscosity 46 cSt at 50°C

REGOLAZIONE  
ADJUSTMENT →

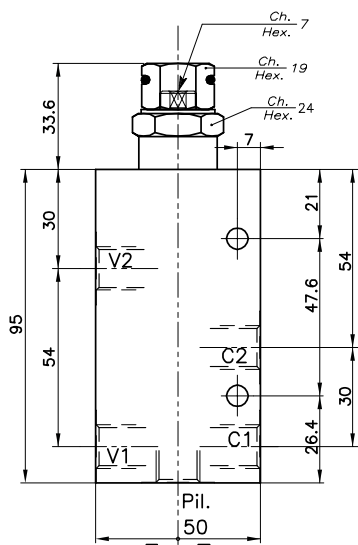

Grano  
Dowel  
(X)

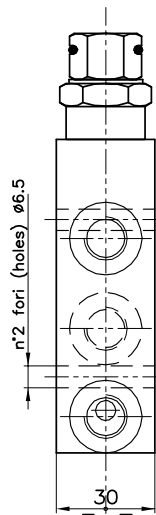

## DIMENSIONI DIMENSIONS

Campo taratura Setting range	Attacchi Port size V2-C2 GAS (BSPP)	Luce nominale Rated size DN	Portata max Max flow-rate l/min - GPM
874	1/4"	6	25-6

## ESEMPIO TIPICO DI CIRCUITO TYPICAL CIRCUIT EXAMPLE

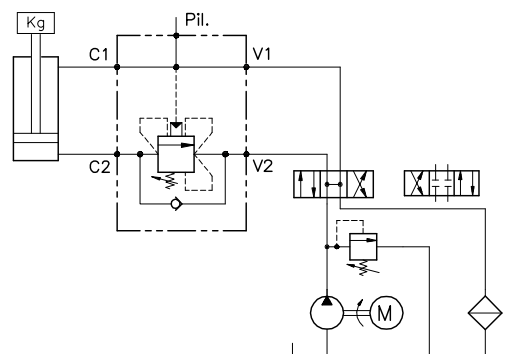

## CODICE DI ORDINAZIONE HOW TO ORDER

001 . 874 . 0 X 0 . A

Campo taratura / Setting range

874

Campo taratura 60÷350 bar (molla colore giallo)  
Setting range 60÷350 bar (yellow spring)

Taratura standard (Q=5 l/1')  
Std. bar setting Q=5 l/1')

250 bar

Incr. press. - bar giro/vite  
Pressure rise - turn of screw  
(75)

Rapporto di pilotaggio  
Pilot ratios

O | 4 : 1

Regolazione  
Adjustment

X | Grano - Dowel

Collettore  
Body

A | Acciaio zincato  
Zinc plated steel

# OWC-DE-...-LU-...

VALVOLA BILANCIAMENTO, BLOCCO E CONTROLLO MOVIMENTO A DOPPIO EFFETTO CON COLLETTORE IN LINEA

DOUBLE COUNTERBALANCE VALVE WITH IN LINE BODY

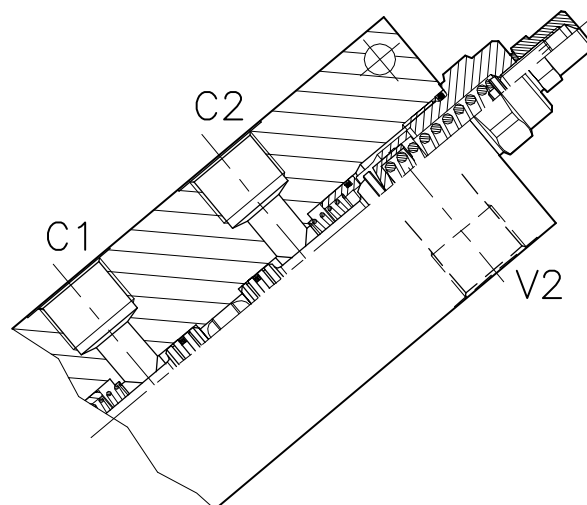
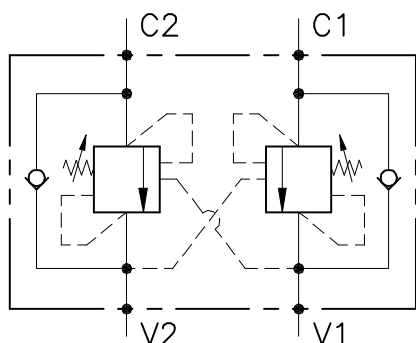

## CARATTERISTICHE

Luce nominale	<b>DN 12/14</b>
Portata min/max	<b>1/160 l/min - 0.26/42.3 GPM</b>
Pressione max. di picco	<b>350 bar - 5075 PSI</b>
Pressione max. di taratura	<b>350 bar - 5075 PSI</b>
Rapporto di pilotaggio standard	<b>6.2 : 1</b>
Temperatura ambiente	<b>-30°C + 50°C</b>
Temperatura olio	<b>-30°C + 80°C</b>
Filtraggio consigliato	<b>30 micron</b>
Coppia di serraggio	
Peso	

## PERFORMANCE

Rated size
Min/max flow-rate
Max peak pressure
Max setting pressure
Standard pilot ratio
Room temperature
Oil temperature
Recommended filtration
Tightening torque
Weight

### NOTE:

La taratura deve essere **1.3** volte maggiore della pressione indotta dal carico.

Valve should be set at **1.3** times load induced pressure.

### ESEMPIO/EXAMPLE:

Pressione di lavoro max:

Max working pressure:

**350 bar / 1.3 = 270 bar**

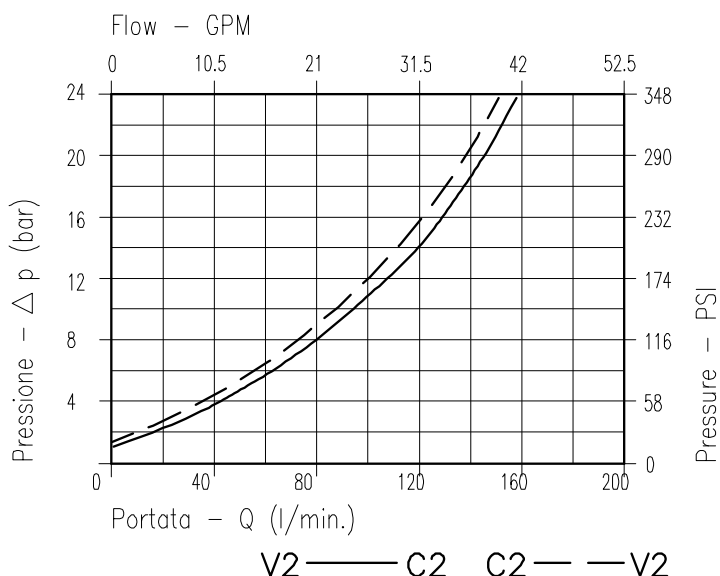

Viscosità olio 46 cSt a 50°C  
Oil viscosity 46 cSt at 50°C

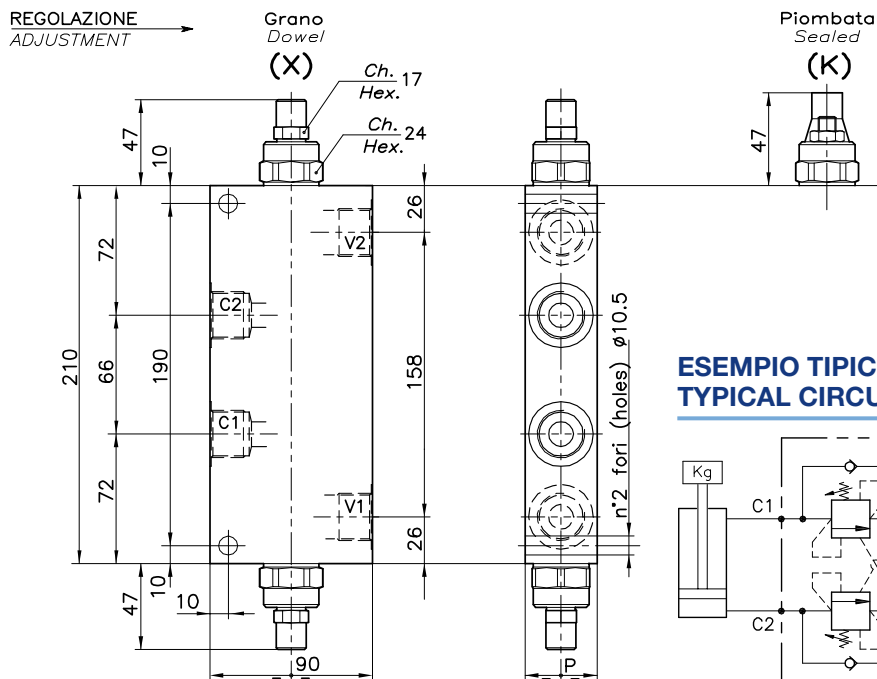

## ESEMPIO TIPICO DI CIRCUITO TYPICAL CIRCUIT EXAMPLE

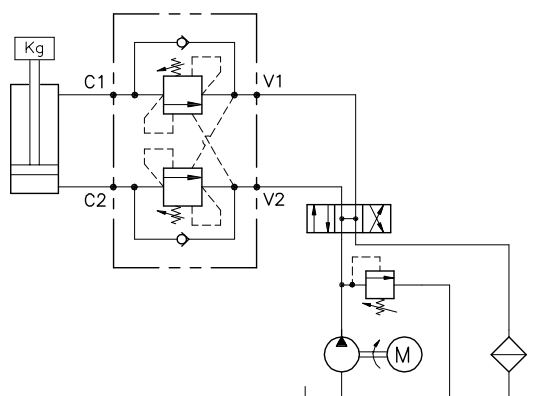

## DIMENSIONI DIMENSIONS

Campo taratura Setting range	P	Attacchi Port size V1-C1 V2-C2 GAS (BSP)	Luce nominale Rated size DN	Portata max Max flow-rate l/min - GPM
453	40	3/4"	12	120-31
454	50	1"	14	160-42

## CODICE DI ORDINAZIONE HOW TO ORDER

001 . 453 . 0 X 0 . A

Campo taratura / Setting range

453

454

Campo taratura 60÷350 bar (molla colore giallo)  
Setting range 60÷350 bar (yellow spring)

Taratura standard (Q=5 l/1')  
Std. bar setting Q=5 l/1')

**250 bar**

Incr. press. - bar giro/vite  
Pressure rise - turn of screw

**(125)**

Rapporto di pilotaggio  
Pilot ratios

O	6.20 : 1
G	4 : 1

Regolazione  
Adjustment

X	Grano - Dowel
K	Piombata - Sealed

Collettore  
Body

A	Acciaio zincato Zinc plated steel
---	--------------------------------------

453

Collettore possibile in AL togliendo "A"  
Available aluminium body without "A"

# WB-C-DE-LU-....-....

VALVOLA BILANCIAMENTO, BLOCCO E CONTROLLO MOVIMENTO A DOPPIO EFFETTO CON COLLETTORE IN LINEA

DOUBLE COUNTERBALANCE VALVE WITH IN LINE BODY

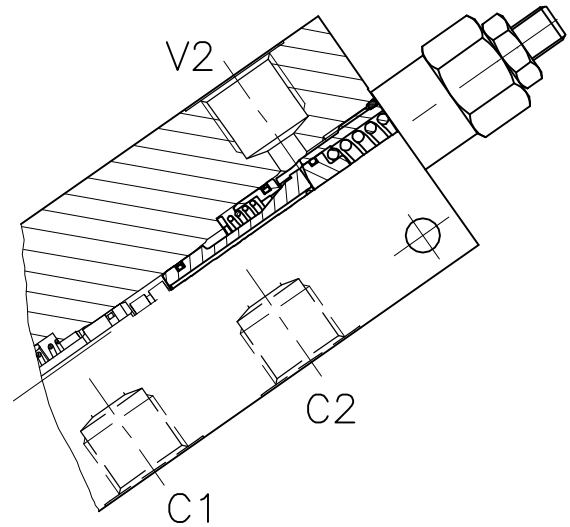
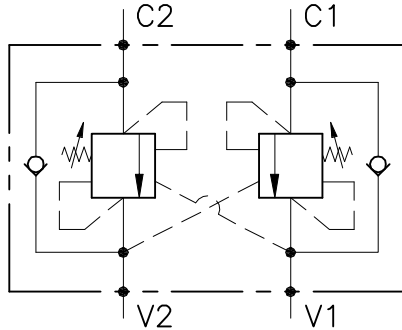

## CARATTERISTICHE

Luce nominale  
Portata min/max  
Pressione max. di picco  
Pressione max. di taratura  
Rapporto di pilotaggio standard  
Temperatura ambiente  
Temperatura olio  
Filtraggio consigliato  
Coppia di serraggio  
Peso

**DN 6/8/10**  
**1/60 l/min - 0.26/15.9 GPM**  
**350 bar - 5075 PSI**  
**350 bar - 5075 PSI**  
**4.25 : 1**  
**-30°C + 50°C**  
**-30°C + 80°C**  
**30 micron**

## PERFORMANCE

Rated size  
Min/max flow-rate  
Max peak pressure  
Max setting pressure  
Standard pilot ratio  
Room temperature  
Oil temperature  
Recommended filtration  
Tightening torque  
Weight

### NOTE:

La taratura deve essere **1.3** volte maggiore della pressione indotta dal carico.

Valve should be set at **1.3** times load induced pressure.

### ESEMPIO/EXAMPLE:

Pressione di lavoro max:  
Max working pressure:  
**350 bar / 1.3 = 270 bar**

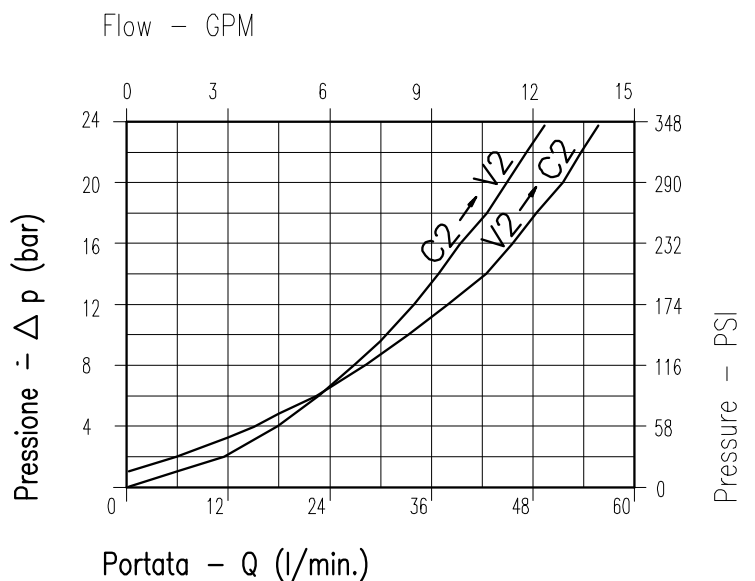

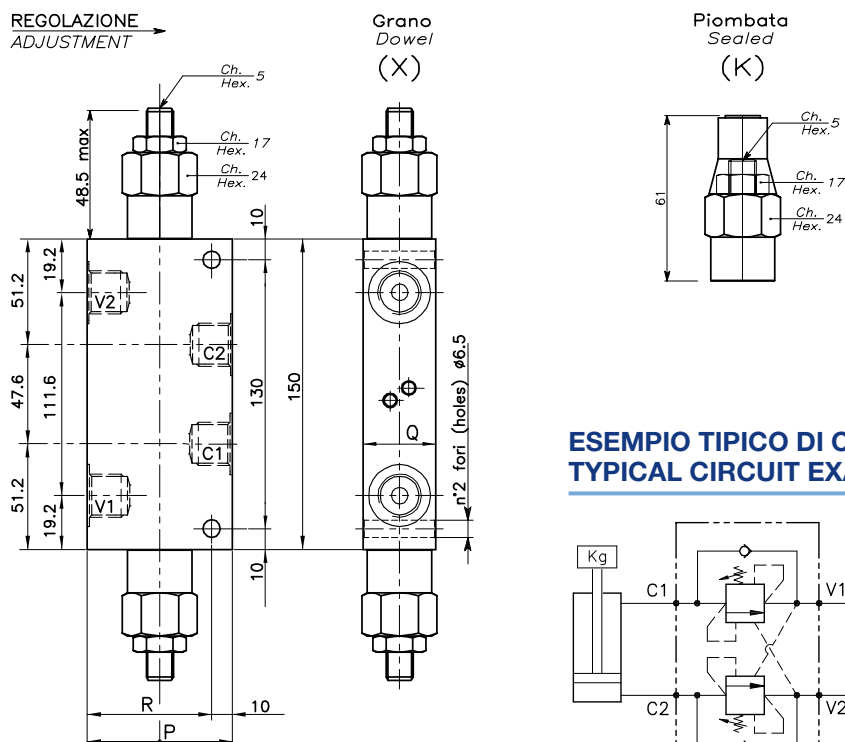

### ESEMPIO TIPICO DI CIRCUITO TYPICAL CIRCUIT EXAMPLE

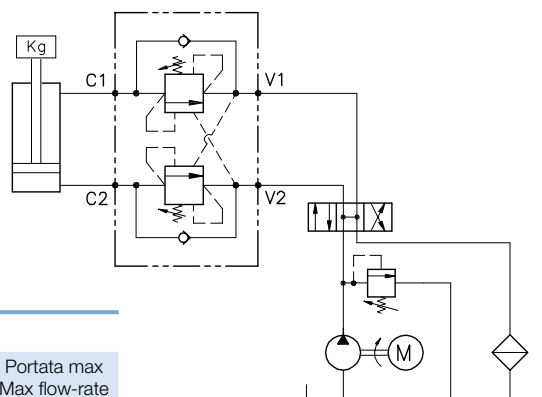

### DIMENSIONI DIMENSIONS

Campo taratura Setting range		P	Q	R	Attacchi Port size V2-C2 V1-C1 GAS (BSPP)	Luce nominale Rated size	Portata max Max flow-rate
						DN	l/min - GPM
256	257	60	30	50	3/8"	8	40-10
258	259	70	35	60	1/2"	10	60 -15

### CODICE DI ORDINAZIONE HOW TO ORDER

N01 . 256 . 0 X 0 . A

Campo taratura / Setting range				Rapporto di pilotaggio Pilot ratios	Regolazione Adjustment	Collettore Body
256		257		O   4.25 : 1	X   Grano - Dowel	A   Acciaio zincato Zinc plated steel
258		259		D   8 : 1	K   Piombata - Sealed	
Campo taratura 30÷220 bar (molla colore verde) Setting range 30÷220 bar (green spring)		Campo taratura 60÷350 bar (molla colore giallo) Setting range 60÷350 bar (yellow spring)				
Taratura standard (Q=5 l/1')	Incr. press. - bar giro/vite	Taratura standard (Q=5 l/1')	Incr. press. - bar giro/vite			
Std. bar setting (Q=5 l/1')	Pressure rise - turn of screw	Std. bar setting (Q=5 l/1')	Pressure rise - turn of screw			
<b>180 bar</b>	<b>(50)</b>	<b>250 bar</b>	<b>(90)</b>			
258	Collettore possibile in AL togliendo "A"					
259	Available aluminium body without "A"					
256						
257						

# OWC-30-DEI-14-L

VALVOLA BILANCIAMENTO, BLOCCO E CONTROLLO MOVIMENTO A DOPPIO EFFETTO CON COLLETTORE IN LINE

DOUBLE COUNTERBALANCE VALVE WITH IN LINE BODY

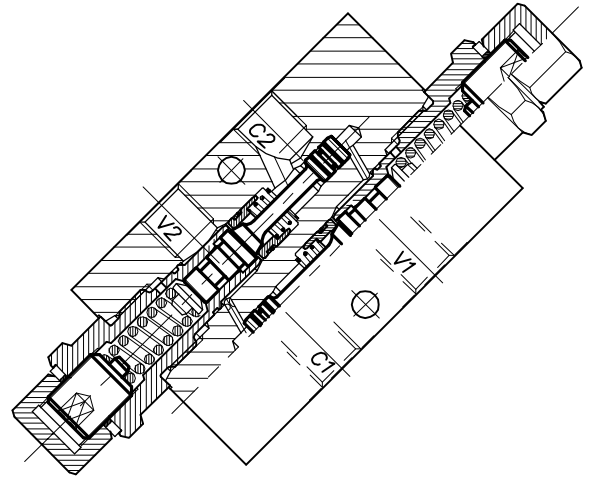
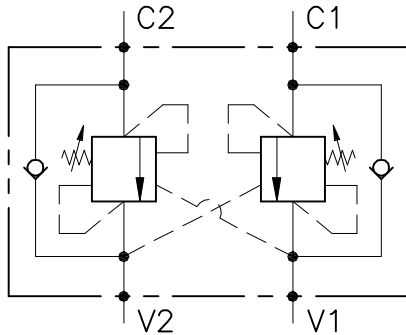

## CARATTERISTICHE

Luce nominale	<b>DN 6</b>
Portata min/max	<b>1/25 l/min - 0.26/6.6 GPM</b>
Pressione max. di picco	<b>350 bar - 5075 PSI</b>
Pressione max. di taratura	<b>350 bar - 5075 PSI</b>
Rapporto di pilotaggio standard	<b>4 : 1</b>
Temperatura ambiente	<b>-30°C + 50°C</b>
Temperatura olio	<b>-30°C + 80°C</b>
Filtraggio consigliato	<b>30 micron</b>
Coppia di serraggio	
Peso	<b>0.300 Kg</b>

## PERFORMANCE

Rated size
Min/max flow-rate
Max peak pressure
Max setting pressure
Standard pilot ratio
Room temperature
Oil temperature
Recommended filtration
Tightening torque
Weight

### NOTE:

La taratura deve essere **1.3** volte maggiore della pressione indotta dal carico.

Valve should be set at **1.3** times load induced pressure.

### ESEMPIO/EXAMPLE:

Pressione di lavoro max:

Max working pressure:

**350 bar / 1.3 = 270 bar**

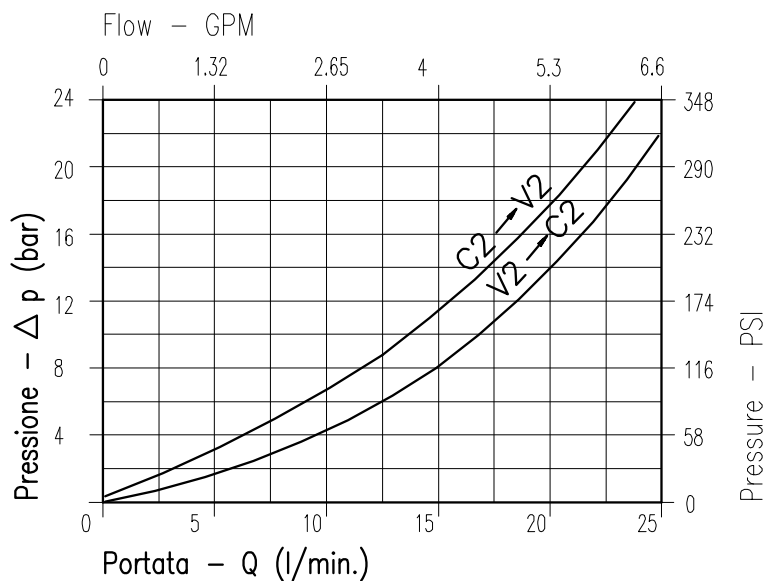

Viscosità olio 46 cSt a 50°C  
Oil viscosity 46 cSt at 50°C



REGOLAZIONE  
ADJUSTMENT

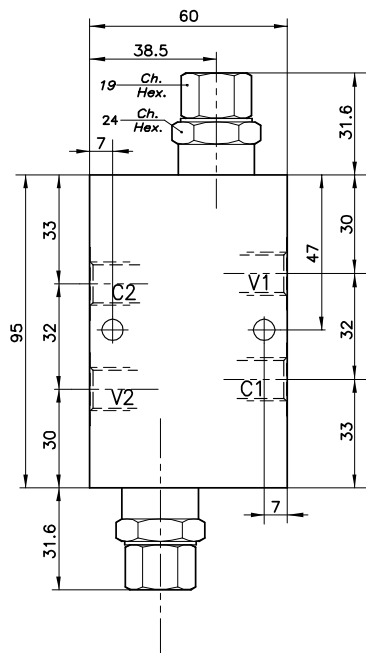

Grano  
Dowel  
(X)

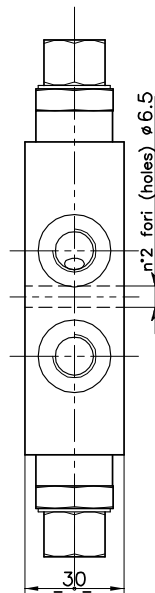

## ESEMPIO TIPICO DI CIRCUITO TYPICAL CIRCUIT EXAMPLE

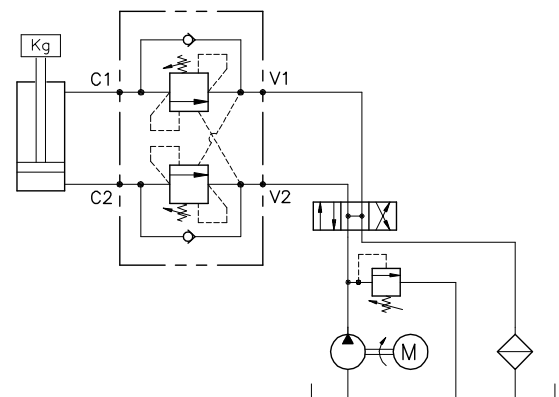

## DIMENSIONI DIMENSIONS

Campo taratura Setting range	Attacchi Port size V1-C1 V2-C2 GAS (BSPF)	Luce nominale Rated size	Portata max Max flow-rate
626	1/4"	DN	l/min - GPM

## CODICE DI ORDINAZIONE HOW TO ORDER

001 . 626 . 0 X 0 . A

Campo taratura / Setting range

626

Campo taratura 60÷350 bar (molla colore verde)

Setting range 60÷350 bar (green spring)

Taratura standard (Q=5 l/1')  
Std. bar setting Q=5 l/1')

250 bar

Incr. press. - bar giro/vite  
Pressure rise - turn of screw

(75)

Rapporto di pilotaggio  
Pilot ratios

O 4 : 1  
F 7 : 1

Regolazione  
Adjustment

X Grano - Dowel

Collettore  
Body

A Acciaio  
zincato  
Zinc plated  
steel

626

Collettore possibile in AL togliendo "A"  
Available aluminium body without "A"

# A-OWF-DE-...-LU-...

VALVOLA BILANCIAMENTO, BLOCCO E CONTROLLO MOVIMENTO A DOPPIO EFFETTO CON COLLETTORE IN LINEA

DOUBLE COUNTERBALANCE VALVE WITH IN LINE BODY

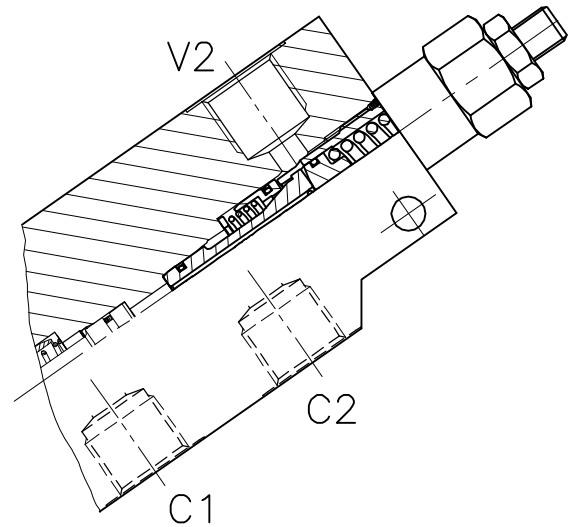
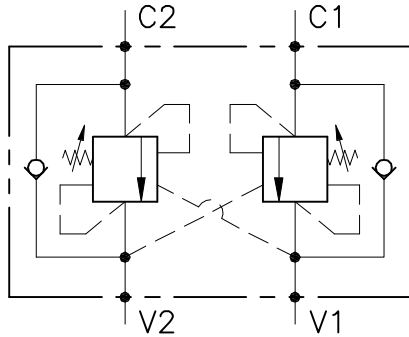

## CARATTERISTICHE

Luce nominale  
Portata min/max  
Pressione max. di picco  
Pressione max. di taratura  
Rapporto di pilotaggio standard  
Temperatura ambiente  
Temperatura olio  
Filtraggio consigliato  
Coppia di serraggio  
Peso

**DN 6/8/10**  
**1/60 l/min - 0.26/15.9 GPM**  
**350 bar - 5075 PSI**  
**350 bar - 5075 PSI**  
**4.25 : 1**  
**-30°C + 50°C**  
**-30°C + 80°C**  
**30 micron**

## PERFORMANCE

Rated size  
Min/max flow-rate  
Max peak pressure  
Max setting pressure  
Standard pilot ratio  
Room temperature  
Oil temperature  
Recommended filtration  
Tightening torque  
Weight

### NOTE:

La taratura deve essere **1.3** volte maggiore della pressione indotta dal carico.

Valve should be set at **1.3** times load induced pressure.

### ESEMPIO/EXAMPLE:

Pressione di lavoro max:

Max working pressure:

**350 bar / 1.3 = 270 bar**

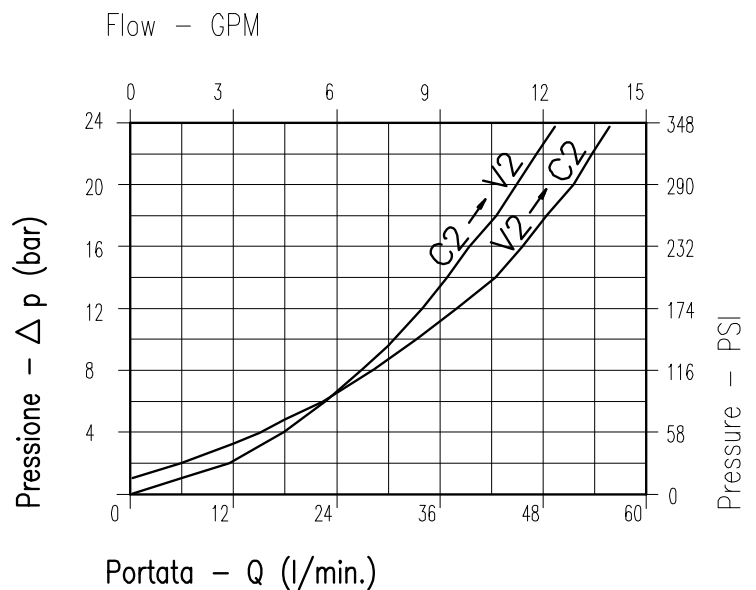

Viscosità olio 46 cSt a 50°C  
Oil viscosity 46 cSt at 50°C

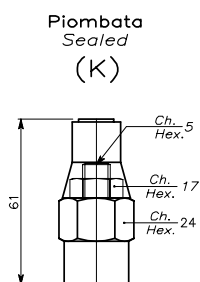
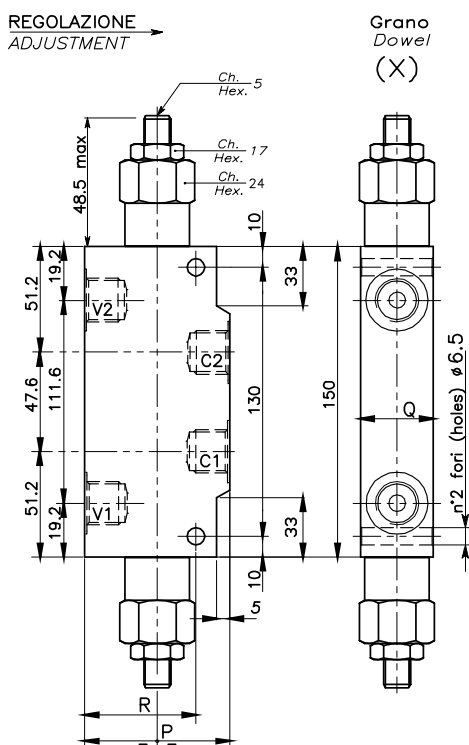

## ESEMPIO TIPO DI CIRCUITO TYPICAL CIRCUIT EXAMPLE

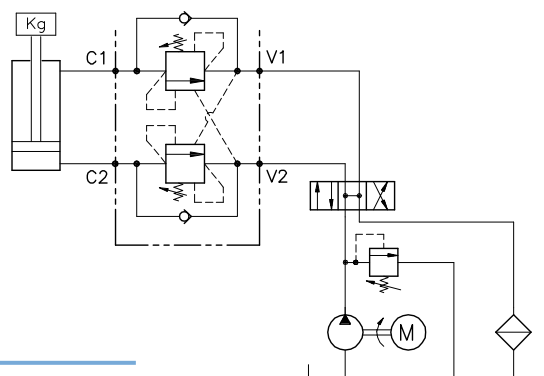

## DIMENSIONI DIMENSIONS

Campo taratura Setting range	P	Q	R	Attacchi Port size V2-C2 V1-C1 GAS (BSPP)	Luce nominale Rated size	Portata max Max flow-rate
				DN		l/min - GPM
079   078	60	30	47,5	1/4"	6	20-5
081   080	60	30	47,5	3/8"	8	40-10
083   082	70	35	55	1/2"	10	60-15

## CODICE DI ORDINAZIONE HOW TO ORDER

N01 . 079 . 0 X 0 . A

Campo taratura / Setting range	
079	078
081	080
083	082
Campo taratura 30÷220 bar (molla colore verde) Setting range 30÷220 bar (green spring)	Campo taratura 60÷350 bar (molla colore giallo) Setting range 60÷350 bar (yellow spring)
Taratura standard (Q=5 l/1') Std. bar setting (Q=5 l/1') <b>180 bar</b>	Incr. press. - bar giro/vite Pressure rise - turn of screw <b>(50)</b>
Taratura standard (Q=5 l/1') Std. bar setting (Q=5 l/1') <b>250 bar</b>	Incr. press. - bar giro/vite Pressure rise - turn of screw <b>(90)</b>

Rapporto di pilotaggio Pilot ratios	
O	4.25 : 1
D	8 : 1

Regolazione Adjustment	
X	Grano - Dowel
K	Piombata - Sealed

Collettore Body	
A	Acciaio zincato Zinc plated steel

# A-OWC-DE-...-OIL-...

VALVOLA BILANCIAMENTO, BLOCCO E CONTROLLO MOVIMENTO A DOPPIO EFFETTO CON COLLETTORE IN LINEA

DOUBLE COUNTERBALANCE VALVE WITH IN LINE BODY

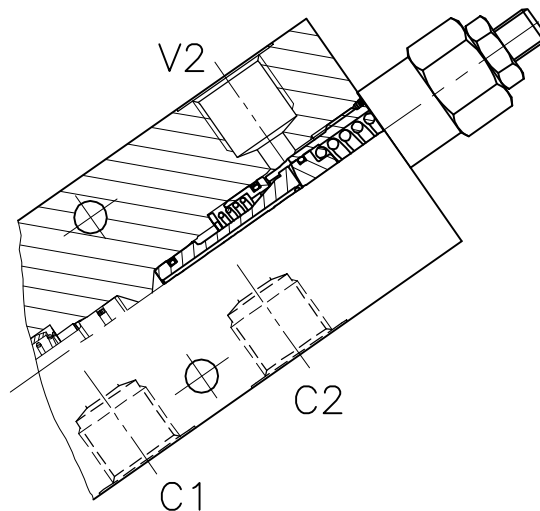
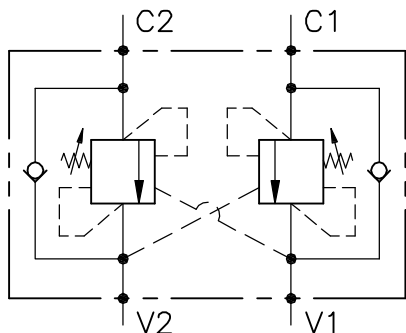

## CARATTERISTICHE

Luce nominale	<b>DN 8/10</b>
Portata min/max	<b>1/60 l/min - 0.26/15.9 GPM</b>
Pressione max. di picco	<b>350 bar - 5075 PSI</b>
Pressione max. di taratura	<b>350 bar - 5075 PSI</b>
Rapporto di pilotaggio standard	<b>4.25 : 1</b>
Temperatura ambiente	<b>-30°C + 50°C</b>
Temperatura olio	<b>-30°C + 80°C</b>
Filtraggio consigliato	<b>30 micron</b>
Peso	<b>2.586 Kg</b>

## PERFORMANCE

Rated size
Min/max flow-rate
Max peak pressure
Max setting pressure
Standard pilot ratio
Room temperature
Oil temperature
Recommended filtration
Weight

### NOTE:

La taratura deve essere **1.3** volte maggiore della pressione indotta dal carico.

Valve should be set at **1.3** times load induced pressure.

### ESEMPIO/EXAMPLE:

Pressione di lavoro max:

Max working pressure:

**350 bar / 1.3 = 270 bar**

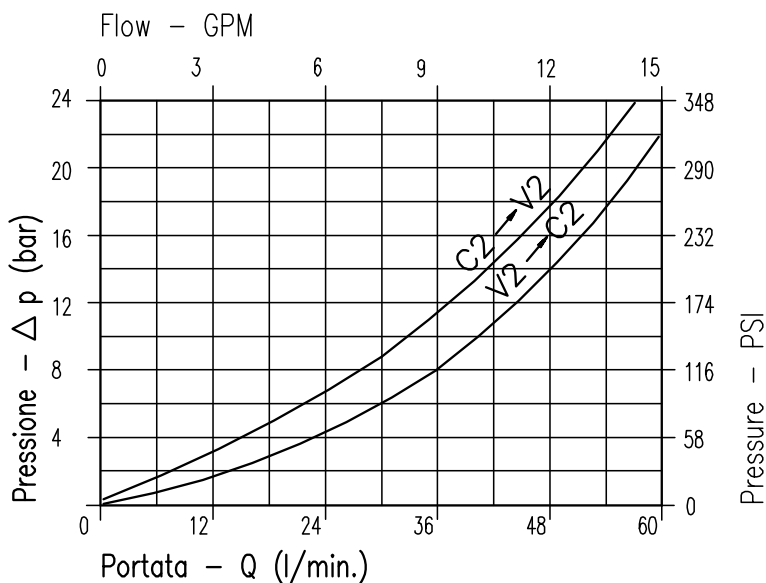

Viscosità olio 46 cSt a 50°C  
Oil viscosity 46 cSt at 50°C

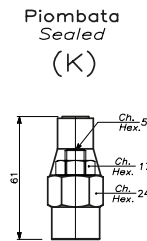
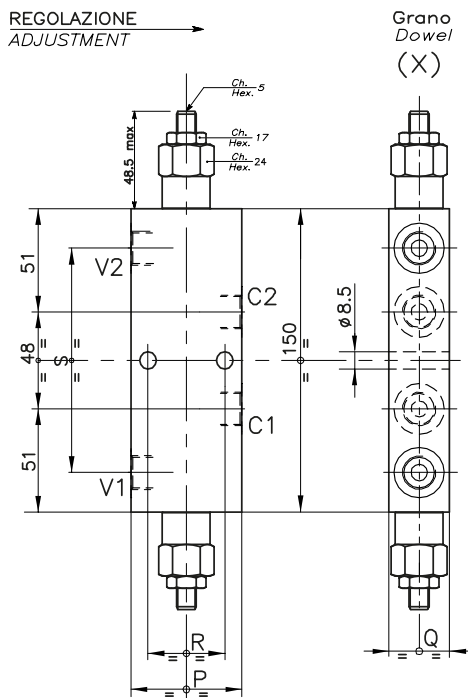

### ESEMPIO TIPICO DI CIRCUITO TYPICAL CIRCUIT EXAMPLE

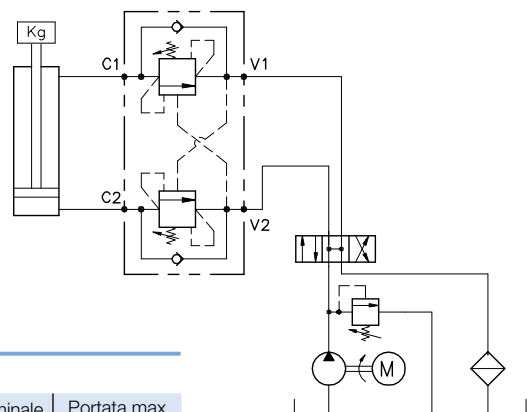

### DIMENSIONI DIMENSIONS

Campo taratura Setting range	P	Q	R	S	Attacchi Port size V2-C2 V1-C1 GAS (BSPP)	Luce nominale Rated size DN	Portata max Max flow-rate l/min - GPM
697   660	55	30	38	109,6	3/8"	8	40-10
696   695	65	35	43	112	1/2"	10	60-15

### CODICE DI ORDINAZIONE HOW TO ORDER

N01 . 697 . 0 X 0 . A

Campo taratura / Setting range			
697		257	
696		695	
Campo taratura 30÷220 bar (molla colore verde)		Campo taratura 60÷350 bar (molla colore giallo)	
Setting range 30÷220 bar (green spring)		Setting range 60÷350 bar (yellow spring)	
Taratura standard (Q=5 l/1')	Incr. press. - bar giro/vite	Taratura standard (Q=5 l/1')	Incr. press. - bar giro/vite
Std. bar setting (Q=5 l/1')	Pressure rise - turn of screw	Std. bar setting (Q=5 l/1')	Pressure rise - turn of screw
<b>180 bar</b>	<b>(50)</b>	<b>250 bar</b>	<b>(90)</b>

Rapporto  
di pilotaggio  
Pilot ratios

O	4.25 : 1
D	8 : 1

Regolazione  
Adjustment

X	Grano - Dowel
K	Piombata - Sealed

Collettore  
Body

A	Acciaio zincato Zinc plated steel
---	--

660	
697	Collettore possibile in AL togliendo "A"
695	Available aluminium body without "A"
696	

# WB-DE-...-OIL-...

VALVOLA BILANCIAMENTO, BLOCCO E CONTROLLO MOVIMENTO A DOPPIO EFFETTO CON COLLETTORE IN LINEA

DOUBLE COUNTERBALANCE VALVE WITH IN LINE BODY

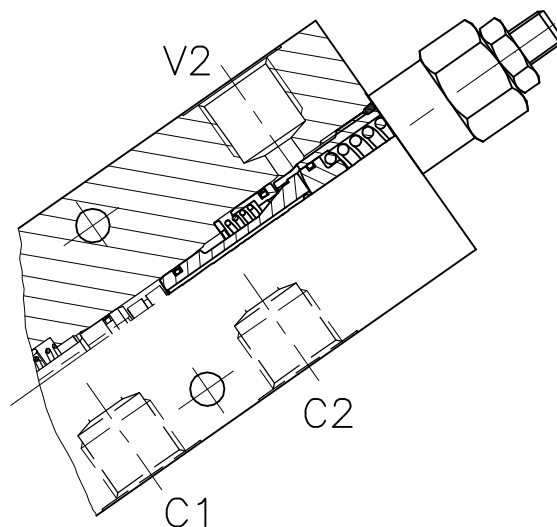
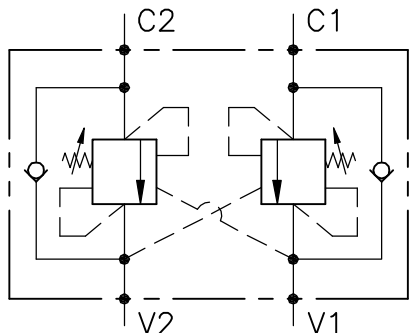

## CARATTERISTICHE

Luce nominale	<b>DN 8/10</b>
Portata min/max	<b>5/60 l/min - 0.26/15.9 GPM</b>
Pressione max. di picco	<b>350 bar - 5075 PSI</b>
Pressione max. di taratura	<b>350 bar - 5075 PSI</b>
Rapporto di pilotaggio standard	<b>4.25 : 1</b>
Temperatura ambiente	<b>-30°C + 50°C</b>
Temperatura olio	<b>-30°C + 80°C</b>
Filtraggio consigliato	<b>30 micron</b>
Peso	<b>3/8" Kg</b>
Peso	<b>1/2" Kg</b>

## PERFORMANCE

Rated size
Min/max flow-rate
Max peak pressure
Max setting pressure
Standard pilot ratio
Room temperature
Oil temperature
Recommended filtration
Weight
Weight

### NOTE:

La taratura deve essere **1.3** volte maggiore della pressione indotta dal carico.

Valve should be set at **1.3** times load induced pressure.

### ESEMPIO/EXAMPLE:

Pressione di lavoro max:

Max working pressure:

**350 bar / 1.3 = 270 bar**

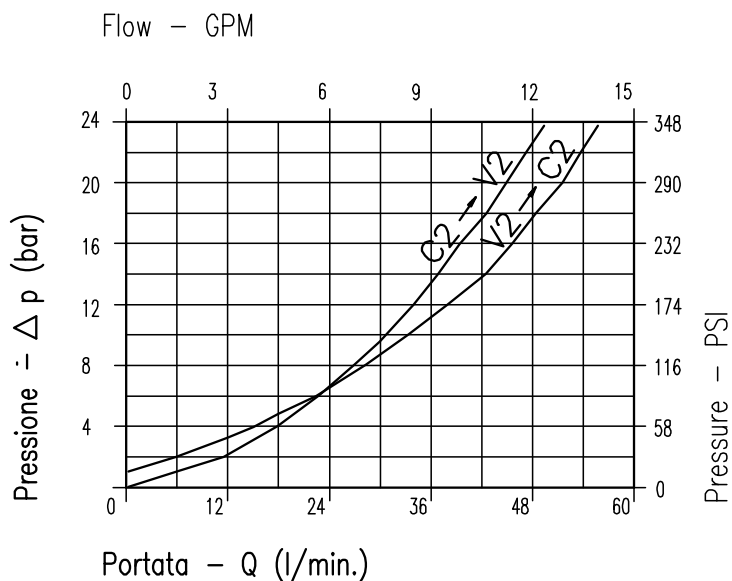

Viscosità olio 46 cSt a 50°C  
Oil viscosity 46 cSt at 50°C

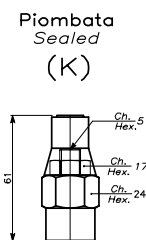
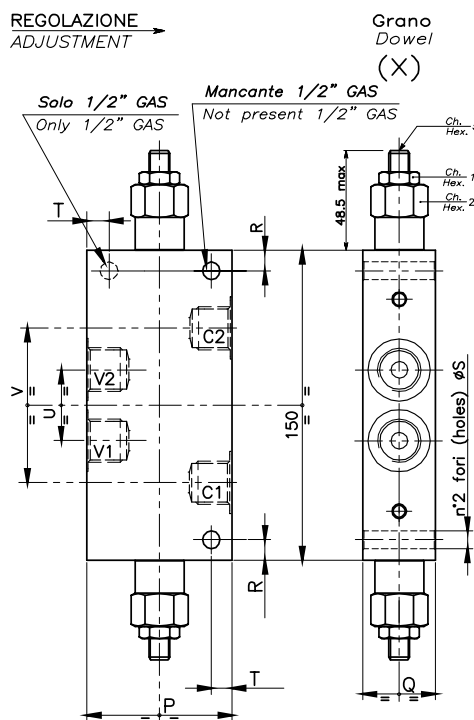

### ESEMPIO TIPICO DI CIRCUITO TYPICAL CIRCUIT EXAMPLE

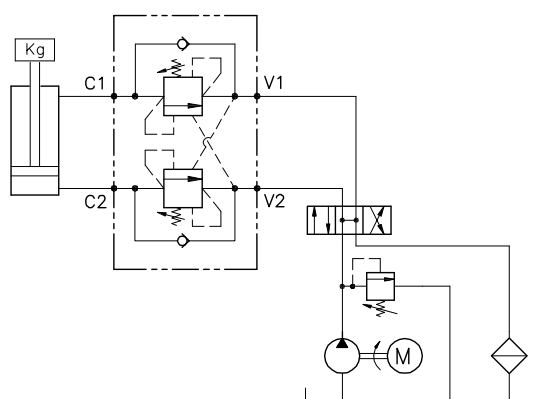

### DIMENSIONI DIMENSIONS

Campo taratura Setting range	P	Q	R	S	T	U	V	Attacchi Port size V2-C2 GAS (BSP)	Portata max Max flow-rate l/min - GPM
651	60	30	23	6.5	14	34	69	3/8"	40-10
115	70	35	12.5	8.5	8	36	80	1/2"	60-15

### CODICE DI ORDINAZIONE HOW TO ORDER

N01 . 651 . 0 X 0 . A

Campo taratura / Setting range  
651  
115

Campo taratura 60÷350 bar (molla colore giallo)  
Setting range 60÷350 bar (yellow spring)

Taratura standard (Q=5 l/1')  
Std. bar setting Q=5 l/1')

250 bar

Incr. press. - bar giro/vite  
Pressure rise - turn of screw  
(90)

Rapporto di pilotaggio  
Pilot ratios

O 4,25 : 1  
D 8 : 1

Regolazione  
Adjustment

X Grano - Dowel  
K Piombata - Sealed

Collettore  
Body

A Acciaio zincato  
Zinc plated steel

115

Collettore possibile in AL togliendo "A"  
Available aluminium body without "A"

# A-WB-CC-DE-LU-...-...

VALVOLA BILANCIAMENTO, BLOCCO E CONTROLLO MOVIMENTO A DOPPIO EFFETTO, CON COLLETTORE IN LINEA

DOUBLE COUNTERBALANCE VALVE FOR CLOSED CENTRE SPOOL WITH IN LINE BODY

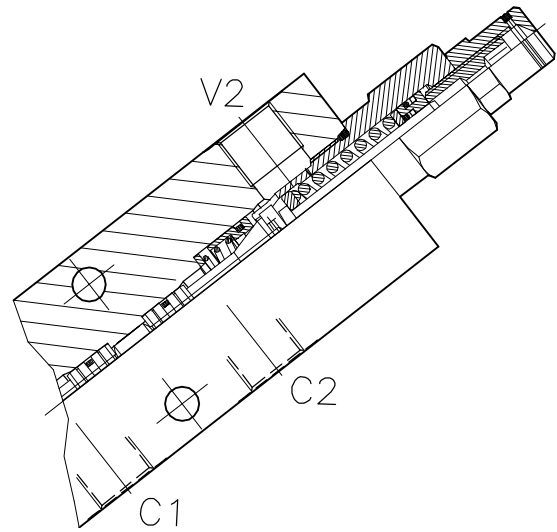
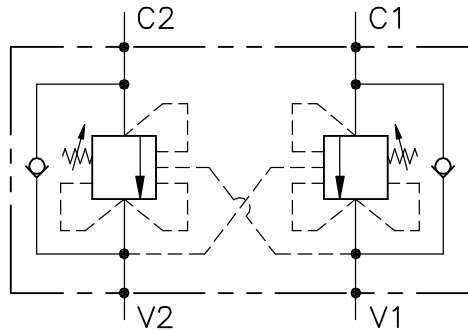

## CARATTERISTICHE

Luce nominale	<b>DN 6/8/10</b>
Portata min/max	<b>1/25 l/min - 0.26/6.6 GPM</b>
Pressione max. di picco	<b>350 bar - 5075 PSI</b>
Pressione max. di taratura	<b>350 bar - 5075 PSI</b>
Rapporto di pilotaggio standard	<b>4.25 : 1</b>
Temperatura ambiente	<b>-30°C + 50°C</b>
Temperatura olio	<b>-30°C + 80°C</b>
Filtraggio consigliato	<b>30 micron</b>
Coppia di serraggio	
Peso	<b>0.300 Kg</b>

## PERFORMANCE

Rated size
Min/max flow-rate
Max peak pressure
Max setting pressure
Standard pilot ratio
Room temperature
Oil temperature
Recommended filtration
Tightening torque
Weight

### NOTE:

La taratura deve essere 1.3 volte maggiore della pressione indotta dal carico. Valve should be set at 1.3 times load induced pressure.

### ESEMPIO/EXAMPLE:

Pressione di lavoro max **350 bar / 1.3 = 270 bar** Max working pressure  
 Fornitura standard valvola: corpo in acciaio. A richiesta corpo in alluminio. Steel body valves as standard, aluminium body on request

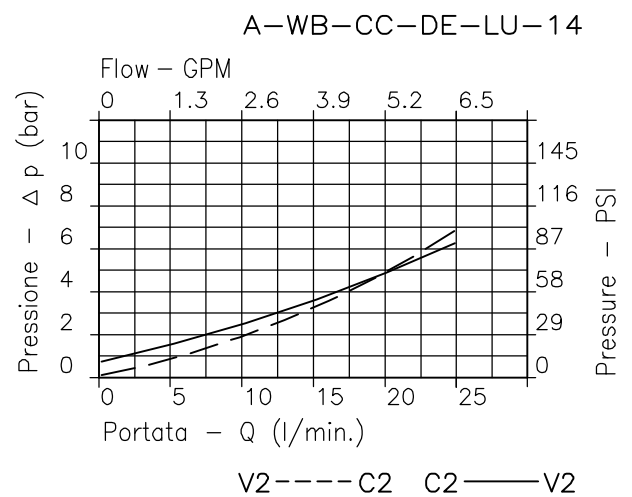
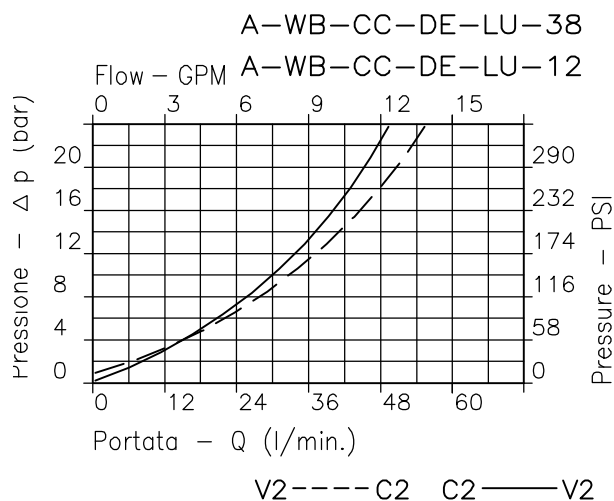

Viscosità olio 46 cSt a 50°C - Oil viscosity 46 cSt at 50°C



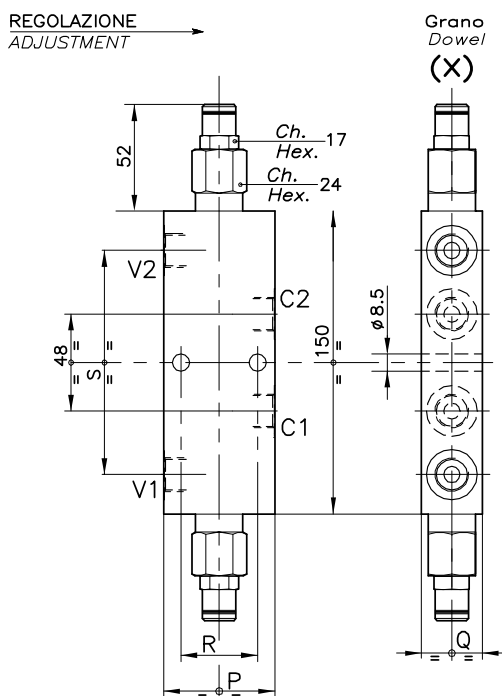

## ESEMPIO TIPICO DI CIRCUITO TYPICAL CIRCUIT EXAMPLE

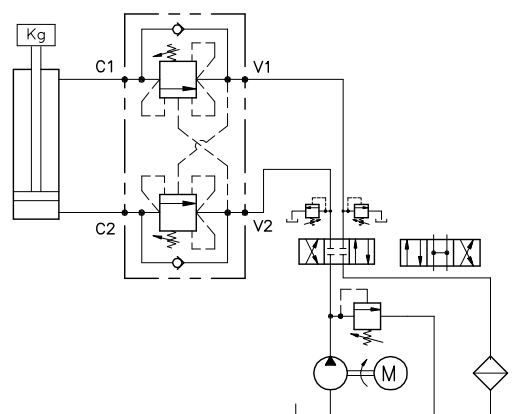

## DIMENSIONI DIMENSIONS

Campo taratura Setting range		P	Q	R	S	Attacchi Port size V2-C2 V1-C1 GAS (BSPP)	Luce nominale Rated size DN	Portata max Max flow-rate l/min - GPM
460	459	55	30	38	109.6	3/8"	8	40-10
462	461	65	35	43	112	1/2"	10	60-15

## CODICE DI ORDINAZIONE HOW TO ORDER

001 . 460 . 0 X 0 . A

Campo taratura / Setting range			
460		459	
462		461	
Campo taratura 30÷220 bar (molla colore verde)		Campo taratura 60÷350 bar (molla colore rosso)	
Setting range 30÷220 bar (green spring)		Setting range 60÷350 bar (red spring)	
Taratura standard (Q=5 l/1')	Incr. press. - bar giro/vite	Taratura standard (Q=5 l/1')	Incr. press. - bar giro/vite
Std. bar setting (Q=5 l/1')	Pressure rise - turn of screw	Std. bar setting (Q=5 l/1')	Pressure rise - turn of screw
<b>180 bar</b>	<b>(60)</b>	<b>250 bar</b>	<b>(140)</b>

Rapporto di pilotaggio Pilot ratios	
O	4.25 : 1
D	8 : 1

Regolazione Adjustment	
X	Grano - Dowel

Collettore Body	
A	Acciaio zincato Zinc plated steel

461	
462	Collettore possibile in AL togliendo "A"
460	Available aluminium body without "A"
459	

# OWC-DE-...-LU-CC-...

VALVOLA BILANCIAMENTO, BLOCCO E CONTROLLO MOVIMENTO A DOPPIO EFFETTO, CON COLLETTORE IN LINEA

DOUBLE COUNTERBALANCE VALVE FOR CLOSED CENTRE SPOOL WITH IN LINE BODY

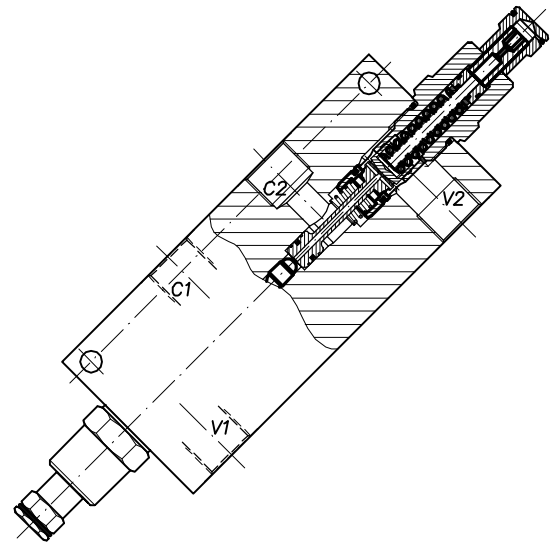
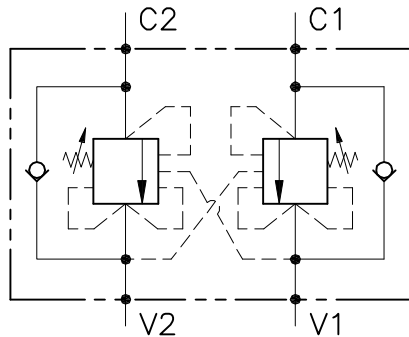

## CARATTERISTICHE

Luce nominale	<b>DN 12/14</b>
Portata min/max	<b>1/160 l/min - 0.26/42.3 GPM</b>
Pressione max. di picco	<b>350 bar - 5075 PSI</b>
Pressione max. di taratura	<b>350 bar - 5075 PSI</b>
Rapporto di pilotaggio standard	<b>6.2 : 1</b>
Temperatura ambiente	<b>-30°C + 50°C</b>
Temperatura olio	<b>-30°C + 80°C</b>
Filtraggio consigliato	<b>30 micron</b>
Peso	

## PERFORMANCE

Rated size
Min/max flow-rate
Max peak pressure
Max setting pressure
Standard pilot ratio
Room temperature
Oil temperature
Recommended filtration
Weight

### NOTE:

La taratura deve essere **1.3** volte maggiore della pressione indotta dal carico.

Valve should be set at **1.3** times load induced pressure.

### ESEMPIO/EXAMPLE:

Pressione di lavoro max:

Max working pressure:

**350 bar / 1.3 = 270 bar**

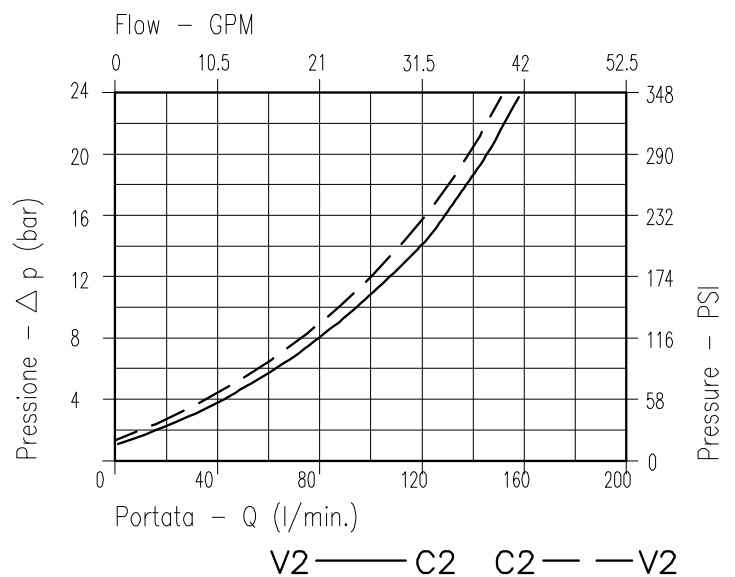

Viscosità olio 46 cSt a 50°C  
Oil viscosity 46 cSt at 50°C

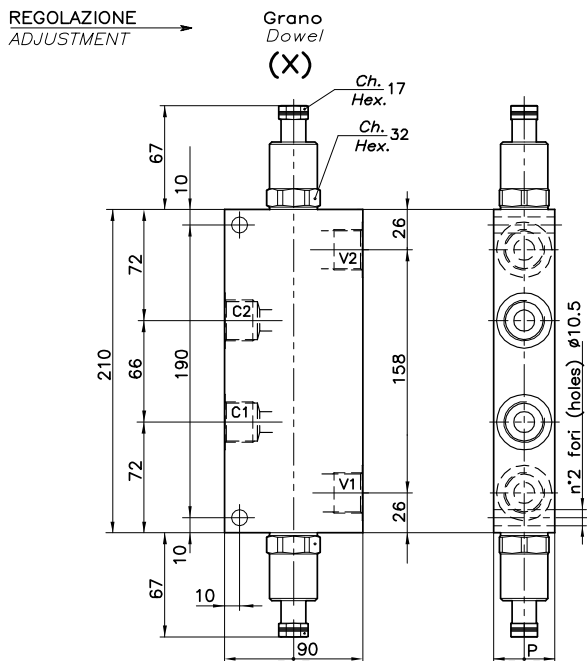

### ESEMPIO TIPICO DI CIRCUITO TYPICAL CIRCUIT EXAMPLE

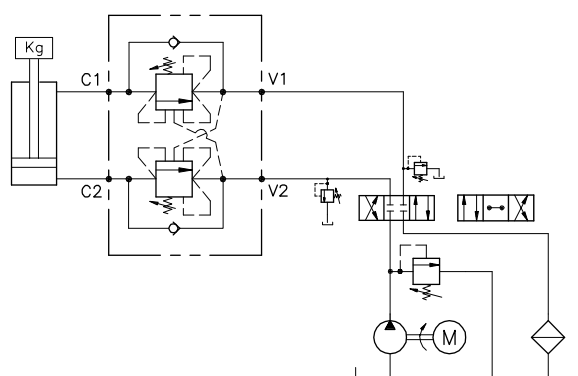

### DIMENSIONI DIMENSIONS

Campo taratura Setting range	P	Attacchi Port size V1-C1 V2-C2 GAS (BSPP)	Luce nominale Rated size DN	Portata max Max flow-rate l/min - GPM
463	40	3/4"	12	120-31
464	50	1"	14	180-47

### CODICE DI ORDINAZIONE HOW TO ORDER

001 . 463 . 0 X 0 . A

Campo taratura / Setting range

463

464

Campo taratura 60÷350 bar (molla colore giallo)  
Setting range 60÷350 bar (yellow spring)

Taratura standard (Q=5 l/1')  
Std. bar setting Q=5 l/1')

**250 bar**

Incr. press. - bar giro/vite  
Pressure rise - turn of screw

**(140)**

Rapporto di pilotaggio  
Pilot ratios

O 6.2 : 1  
G 4 : 1

Regolazione  
Adjustment

X Grano - Dowel

Collettore  
Body

A Acciaio zincato  
Zinc plated steel

463

Collettore possibile in AL togliendo "A"  
Available aluminium body without "A"

# WB-CCN-DE-...-LU-FC2-OIL-...

VALVOLA BILANCIAMENTO, BLOCCO E CONTROLLO MOVIMENTO PER CENTRO CHIUSO, A DOPPIO EFFETTO CON COLLETTORE FLANGIATO

DOUBLE COUNTERBALANCE VALVE FOR CLOSED CENTRE SPOOL WITH FLANGEABLE BODY

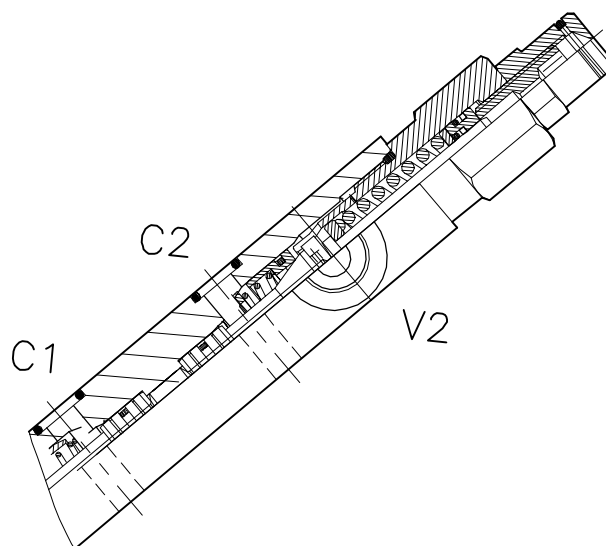
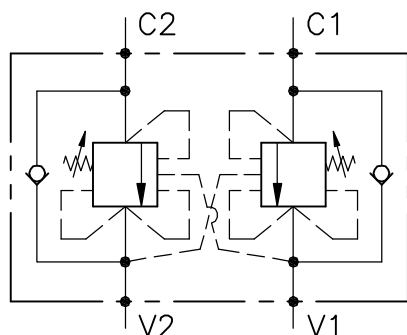

## CARATTERISTICHE

Luce nominale	<b>DN 10</b>
Portata min/max	<b>1/60 l/min - 0.26/15 GPM</b>
Pressione max. di picco	<b>350 bar - 5075 PSI</b>
Pressione max. di taratura	<b>350 bar - 5075 PSI</b>
Rapporto di pilotaggio standard	<b>4.25 : 1</b>
Temperatura ambiente	<b>-30°C + 50°C</b>
Temperatura olio	<b>-30°C + 80°C</b>
Filtraggio consigliato	<b>30 micron</b>
Coppia di serraggio	
Peso	

## PERFORMANCE

Rated size
Min/max flow-rate
Max peak pressure
Max setting pressure
Standard pilot ratio
Room temperature
Oil temperature
Recommended filtration
Tightening torque
Weight

### NOTE:

La taratura deve essere **1.3** volte maggiore della pressione indotta dal carico.

Valve should be set at **1.3** times load induced pressure.

### ESEMPIO/EXAMPLE:

Pressione di lavoro max:

Max working pressure:

**350 bar / 1.3 = 270 bar**

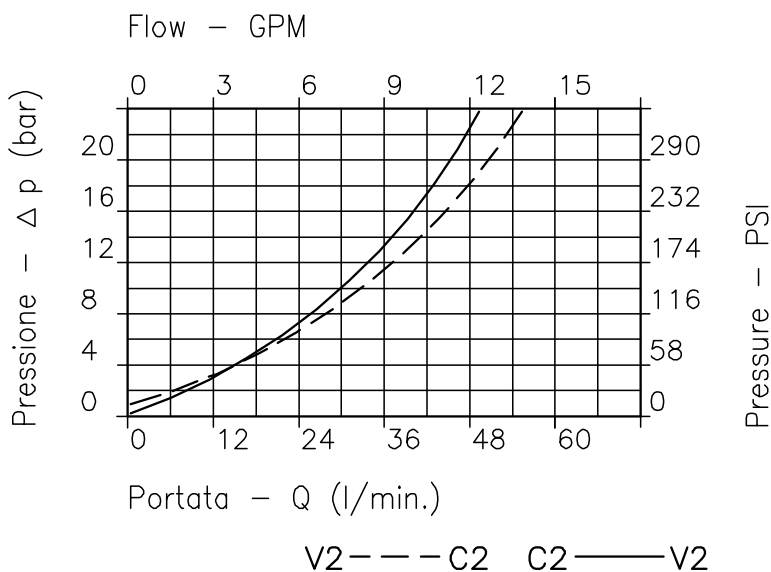

Viscosità olio 46 cSt a 50°C  
Oil viscosity 46 cSt at 50°C

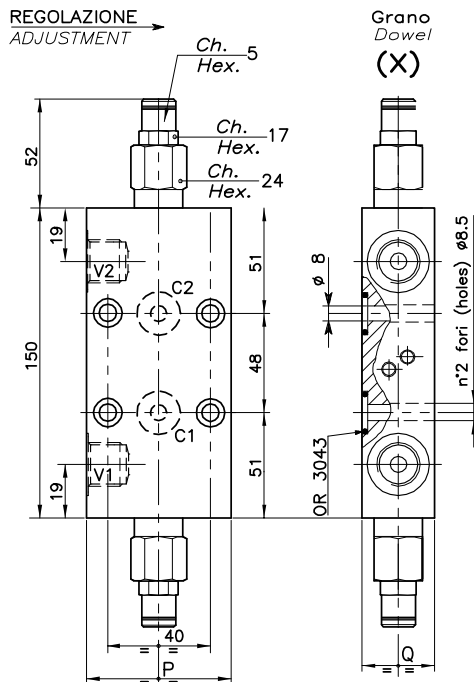

## ESEMPIO TIPICO DI CIRCUITO TYPICAL CIRCUIT EXAMPLE

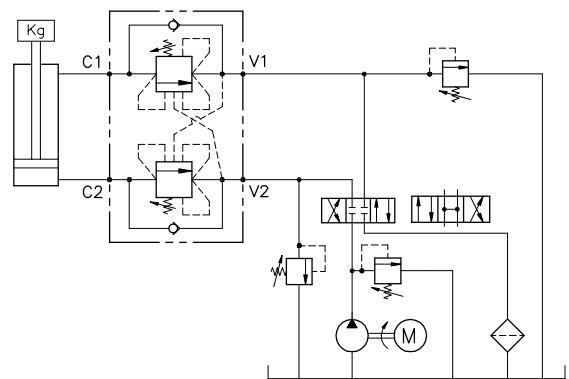

## DIMENSIONI DIMENSIONS

Campo taratura Setting range		P	Q	Attacchi Port size V1-C1 GAS (BSPP)	Luce nominale Rated size DN	Portata max Max flow-rate l/min - GPM
121	120	55	29.5	3/8"	8	40-10
123	122	65	34.5	1/2"	10	60-15

## CODICE DI ORDINAZIONE HOW TO ORDER

001 . 121 . 0 X 0 . A

Campo taratura / Setting range			
121		120	
123		122	
Campo taratura 30÷220 bar (molla colore verde) Setting range 30÷220 bar (green spring)		Campo taratura 60÷350 bar (molla colore rosso) Setting range 60÷350 bar (red spring)	
Taratura standard (Q=5 l/1')	Incr. press. - bar giro/vite	Taratura standard (Q=5 l/1')	Incr. press. - bar giro/vite
Std. bar setting (Q=5 l/1')	Pressure rise - turn of screw	Std. bar setting (Q=5 l/1')	Pressure rise - turn of screw
<b>180 bar</b>	<b>(60)</b>	<b>250 bar</b>	<b>(140)</b>

Rapporto di pilotaggio Pilot ratios	
O	4,25 : 1
D	8 : 1

X  
Regolazione  
Adjustment

Grano - Dowel

A  
Collettore  
Body

Acciaio  
zincato  
Zinc plated  
steel

# OWC-CC-30-DEI-14-L

VALVOLA BILANCIAMENTO, BLOCCO E CONTROLLO MOVIMENTO  
PER CENTRO CHIUSO A DOPPIO EFFETTO  
CON COLLETTORE IN LINEA

DOUBLE COUNTERBALANCE VALVE FOR CLOSED CENTRE  
SPOOL WITH IN LINE BODY

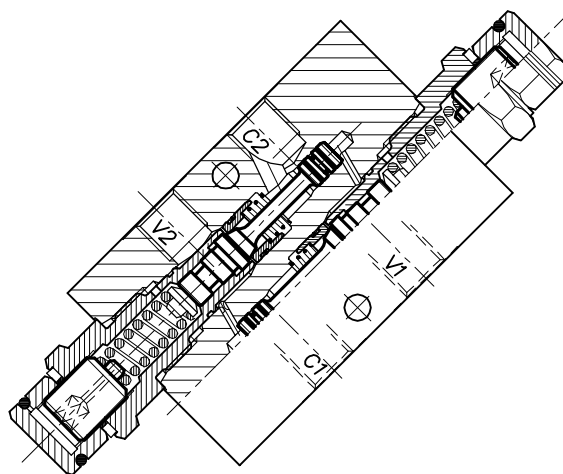
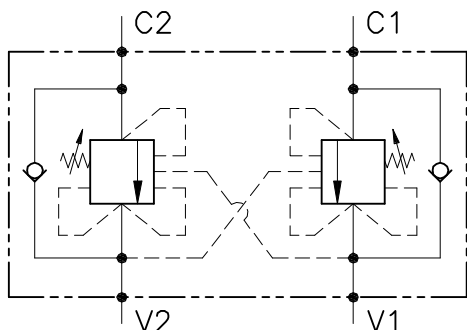

## CARATTERISTICHE

Luce nominale	<b>DN 6</b>
Portata min/max	<b>1/25 l/min - 0.26/6.6 GPM</b>
Pressione max. di picco	<b>350 bar - 5075 PSI</b>
Pressione max. di taratura	<b>350 bar - 5075 PSI</b>
Rapporto di pilotaggio standard	<b>4 : 1</b>
Temperatura ambiente	<b>-30°C + 50°C</b>
Temperatura olio	<b>-30°C + 80°C</b>
Filtraggio consigliato	<b>30 micron</b>
Coppia di serraggio	
Peso	<b>0.300 Kg</b>

## PERFORMANCE

Rated size
Min/max flow-rate
Max peak pressure
Max setting pressure
Standard pilot ratio
Room temperature
Oil temperature
Recommended filtration
Tightening torque
Weight

### NOTE:

La taratura deve essere **1.3** volte maggiore della pressione indotta dal carico.

Valve should be set at **1.3** times load induced pressure.

### ESEMPIO/EXAMPLE:

Pressione di lavoro max:

Max working pressure:

**350 bar / 1.3 = 270 bar**

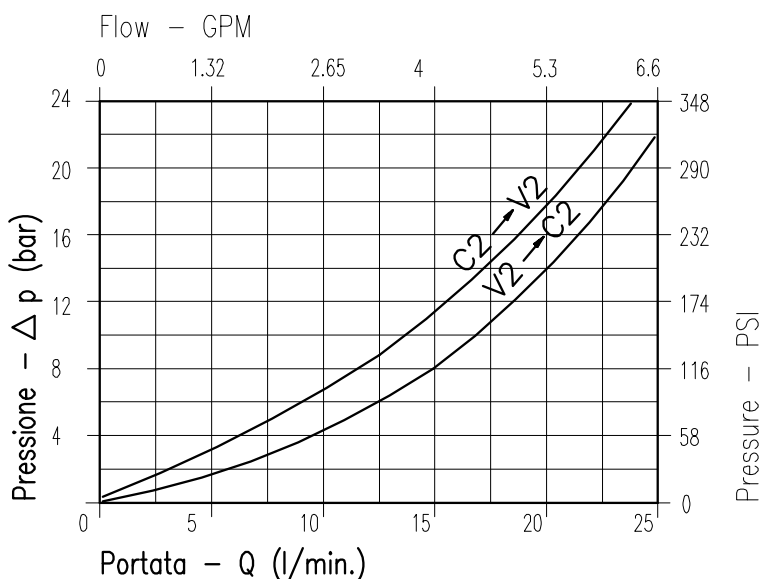

Viscosità olio 46 cSt a 50°C  
Oil viscosity 46 cSt at 50°C

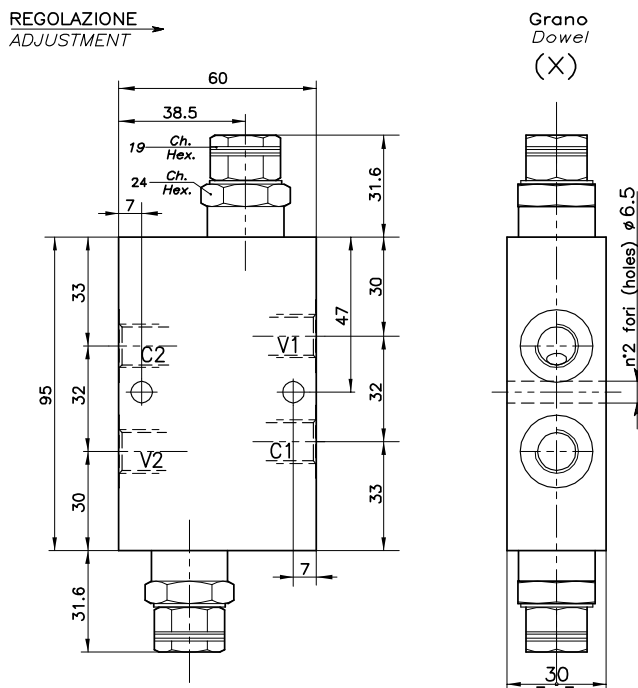

## DIMENSIONI DIMENSIONS

Campo taratura Setting range	Attacchi Port size V1-C1 V2-C2 GAS (BSPP)	Luce nominale Rated size	Portata max Max flow-rate
669	1/4"	DN 6	l/min - GPM 25-6

## ESEMPIO TIPICO DI CIRCUITO TYPICAL CIRCUIT EXAMPLE

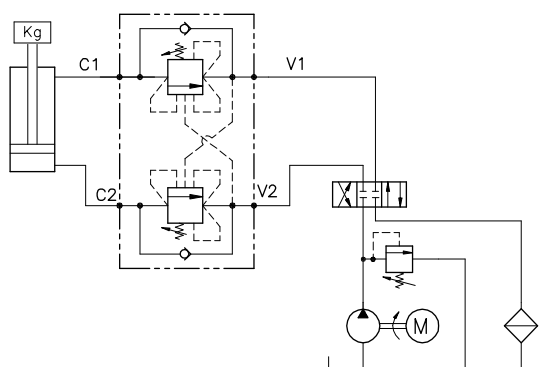

## CODICE DI ORDINAZIONE HOW TO ORDER

001 . 669 . 0 X 0 . A

Campo taratura / Setting range

669

Campo taratura 60÷350 bar (molla colore giallo)  
Setting range 60÷350 bar (yellow spring)

Taratura standard (Q=5 l/1')  
Std. bar setting Q=5 l/1')

250 bar

Incr. press. - bar giro/vite  
Pressure rise - turn of screw  
(75)

Rapporto di pilotaggio  
Pilot ratios

O 4 : 1  
F 7 : 1

Regolazione  
Adjustment

X Grano - Dowel

Collettore  
Body

A Acciaio zincato  
Zinc plated steel

669

Collettore possibile in AL togliendo "A"  
Available aluminium body without "A"

# WB-SE-...-14FCB-...-...

VALVOLA BILANCIAMENTO, BLOCCO E CONTROLLO MOVIMENTO A SEMPLICE EFFETTO CON COLLETTORE FLANGIATO

SINGLE COUNTERBALANCE VALVE WITH FLANGEABLE BODY

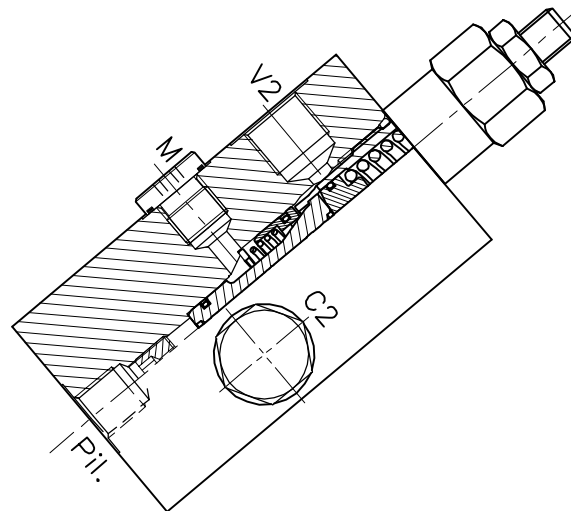
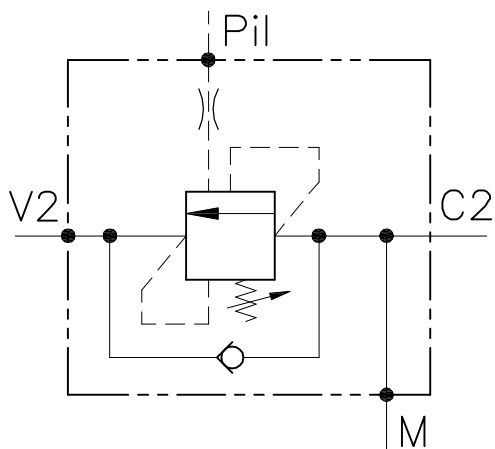

## CARATTERISTICHE

Luce nominale	<b>DN 8/10</b>
Portata min/max	<b>1/60 l/min - 0.26/15.9 GPM</b>
Pressione max. di picco	<b>450 bar - 6525 PSI</b>
Pressione max. di taratura	<b>350 bar - 5075 PSI</b>
Rapporto di pilotaggio standard	<b>4.25 : 1</b>
Temperatura ambiente	<b>-30°C + 50°C</b>
Temperatura olio	<b>-30°C + 80°C</b>
Filtraggio consigliato	<b>30 micron</b>
Peso	

## PERFORMANCE

Rated size
Min/max flow-rate
Max peak pressure
Max setting pressure
Standard pilot ratio
Room temperature
Oil temperature
Recommended filtration
Weight

### NOTE:

La taratura deve essere **1.3** volte maggiore della pressione indotta dal carico.

Valve should be set at **1.3** times load induced pressure.

### ESEMPIO/EXAMPLE:

Pressione di lavoro max:

Max working pressure:

**350 bar / 1.3 = 270 bar**

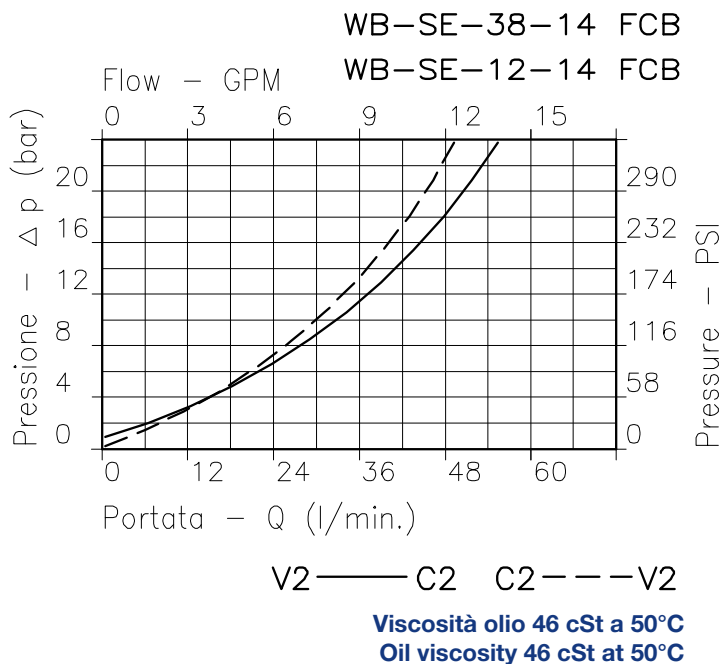



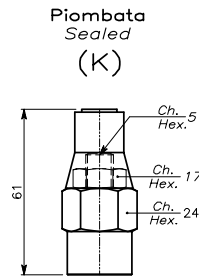
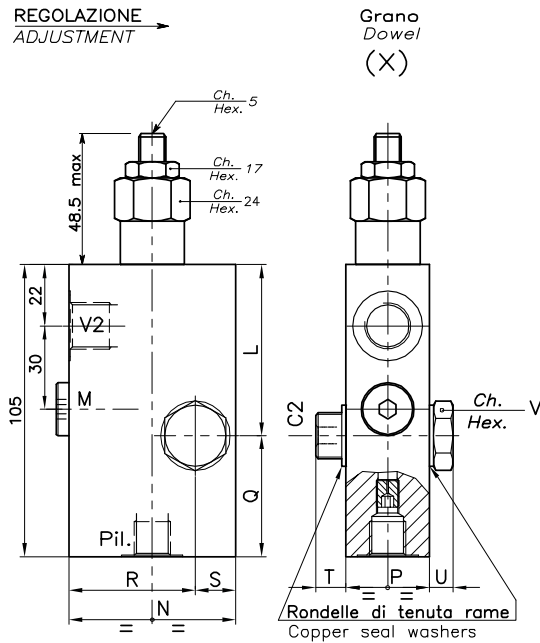

### ESEMPIO TIPICO DI CIRCUITO TYPICAL CIRCUIT EXAMPLE

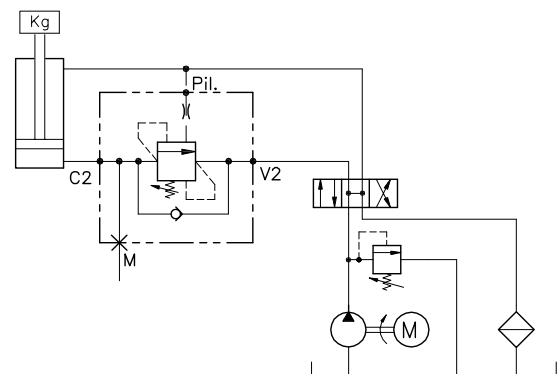

### DIMENSIONI DIMENSIONS

Campo taratura Setting range		L	N	P	Q	R	S	T	U	V	Attacchi Port size V2-C2 GAS (BSPP)	Attacchi Port size M-PIL GAS (BSPP)	Portata max Max flow-rate l/min - GPM
613	614	61.5	60	29.5	43,5	46	14	12	8	22	3/8"	1/4"	40-10
615	616	63	70	34.5	42	55	15	12	8	27	1/2"	1/4"	60-15

### CODICE DI ORDINAZIONE HOW TO ORDER

N01 . 613 . 0 X 0 . A

Campo taratura / Setting range				Rapporto di pilotaggio Pilot ratios		Regolazione Adjustment		Collettore Body	
613		614		A	Ø 0,7 mm	X	Grano - Dowel	A	Acciaio zincato Zinc plated steel
615		616		B	Ø 1 mm	K	Piombata - Sealed		
Campo taratura 30÷220 bar (molla colore verde) Setting range 30÷220 bar (green spring)		Campo taratura 60÷350 bar (molla colore giallo) Setting range 60÷350 bar (yellow spring)		C	Ø 1,2 mm				
Taratura standard (Q=5 l/1')	Incr. press. - bar giro/vite	Taratura standard (Q=5 l/1')	Incr. press. - bar giro/vite	D	Senza grano Without dowel Rapp.pilot Pilot Ratio 8 : 1				
Std. bar setting (Q=5 l/1')	Pressure rise - turn of screw	Std. bar setting (Q=5 l/1')	Pressure rise - turn of screw	O	Senza grano Without dowel				
<b>180 bar</b>	<b>(50)</b>	<b>250 bar</b>	<b>(90)</b>						
613		Collettore possibile in AL togliendo "A"							
614		Available aluminium body without "A"							

# WB-SE-...FBC-...

VALVOLA BILANCIAMENTO, BLOCCO E CONTROLLO MOVIMENTO A SEMPLICE EFFETTO CON COLLETTORE FLANGIATO

SINGLE COUNTERBALANCE VALVE WITH FLANGEABLE BODY

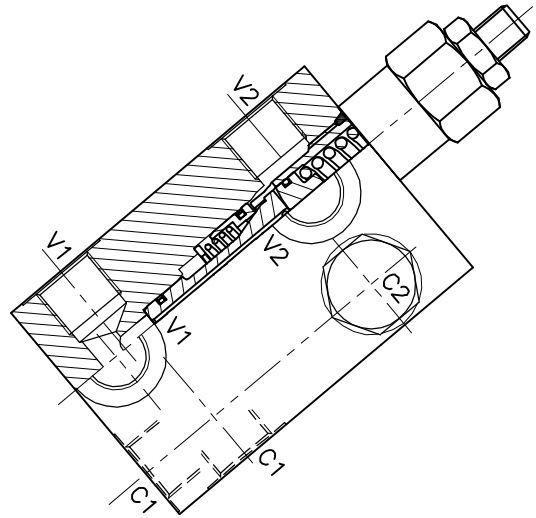
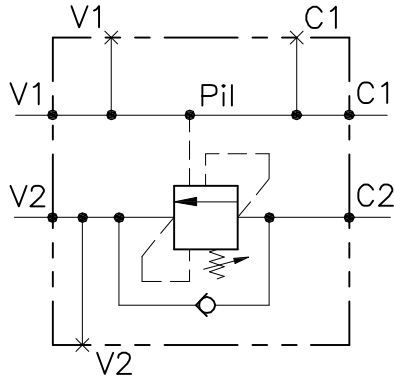

## CARATTERISTICHE

Luce nominale	<b>DN 8/10</b>
Portata min/max	<b>1/60 l/min - 0.26/15.9 GPM</b>
Pressione max. di picco	<b>450 bar - 6525 PSI</b>
Pressione max. di taratura	<b>350 bar - 5075 PSI</b>
Rapporto di pilotaggio standard	<b>4.25 : 1</b>
Temperatura ambiente	<b>-30°C + 50°C</b>
Temperatura olio	<b>-30°C + 80°C</b>
Filtraggio consigliato	<b>30 micron</b>
Peso	

## PERFORMANCE

Rated size
Min/max flow-rate
Max peak pressure
Max setting pressure
Standard pilot ratio
Room temperature
Oil temperature
Recommended filtration
Weight

### NOTE:

La taratura deve essere **1.3** volte maggiore della pressione indotta dal carico.

Valve should be set at **1.3** times load induced pressure.

### ESEMPIO/EXAMPLE:

Pressione di lavoro max:

Max working pressure:

**350 bar / 1.3 = 270 bar**

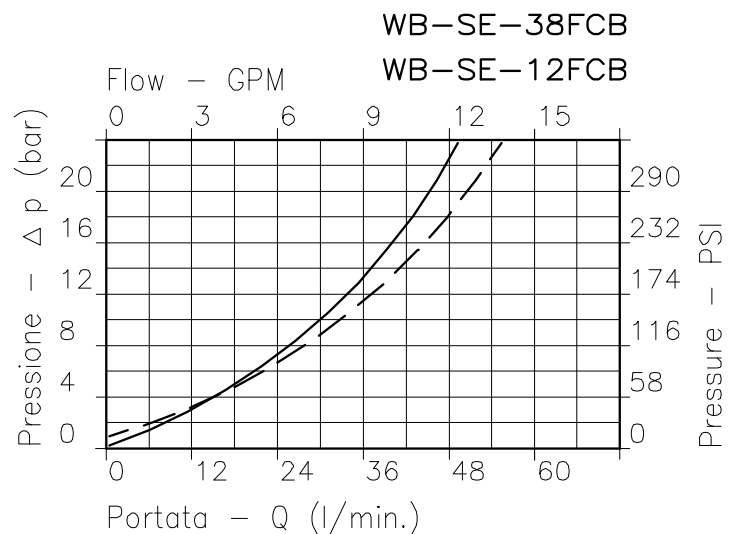

Viscosità olio 46 cSt a 50°C  
Oil viscosity 46 cSt at 50°C

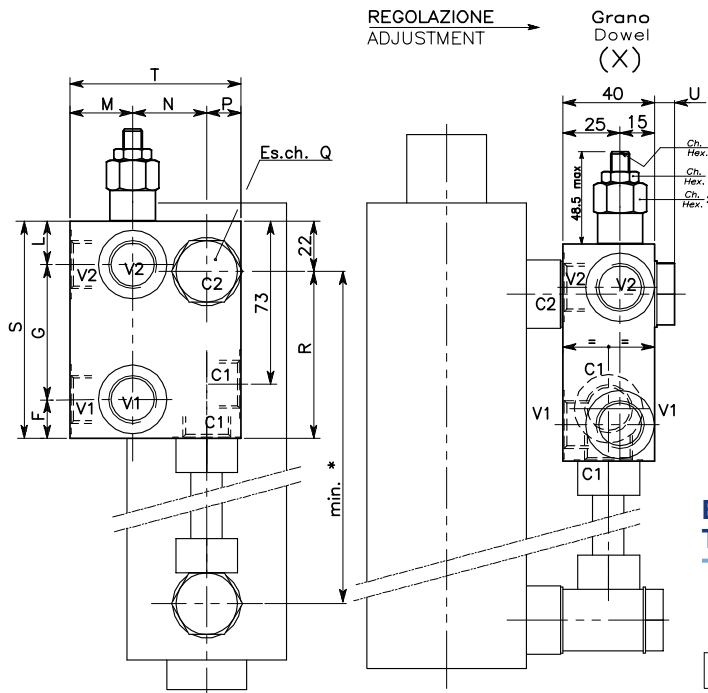

Piombata Sealed (K)

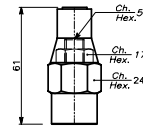

### ESEMPIO TIPICO DI CIRCUITO TYPICAL CIRCUIT EXAMPLE

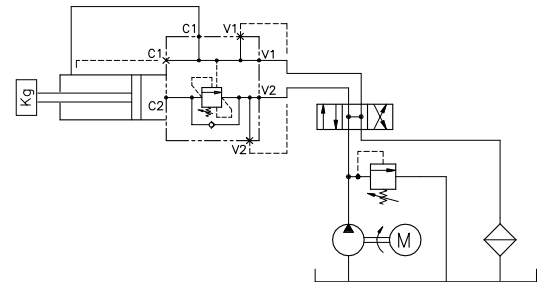

### DIMENSIONI DIMENSIONS

Campo taratura Setting range	F	G	L	M	N	P	Q	R	S	T	U	V	Attacchi Port size V2-C2 GAS (BSPP)	Luce nominale Rated size DN	Portata max Max flow-rate l/min - GPM
284	16	53	21	25	27	13	22	68	90	65	9	11	3/8"	8	40-10
285	16	60	19	27	32	16	27	73	95	75	10	16	1/2"	10	60-15

### CODICE DI ORDINAZIONE HOW TO ORDER

N01 . 284 . 0 X 0 . A

Campo taratura / Setting range

284

285

Campo taratura 60÷350 bar (molla colore giallo)  
Setting range 60÷350 bar (yellow spring)

Taratura standard (Q=5 l/1')  
Std. bar setting Q=5 l/1')

250 bar

Incr. press. - bar giro/vite  
Pressure rise - turn of screw  
(90)

Rapporto di pilotaggio  
Pilot ratios

O 4.25 : 1  
D 8 : 1

Regolazione  
Adjustment

X Grano - Dowel  
K Piombata - Sealed

Collettore  
Body

A Acciaio zincato  
Zinc plated steel

284

Collettore possibile in AL togliendo "A"  
Available aluminium body without "A"

# WB-CC-SE-14-38-L-FCB

VALVOLA BILANCIAMENTO, BLOCCO E CONTROLLO MOVIMENTO  
PER CENTRO CHIUSO CON COLLETTORE FLANGIATO

SINGLE COUNTERBALANCE VALVE FOR CLOSED CENTRE SPOOL  
WITH FLANGEABLE BODY

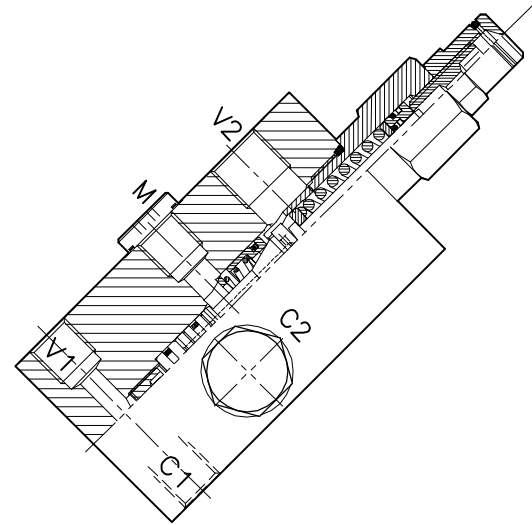
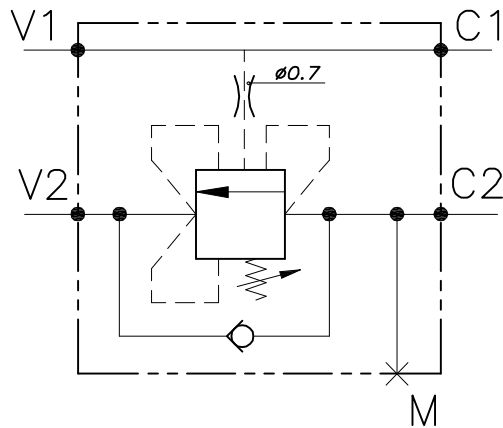

## CARATTERISTICHE

Luce nominale	<b>DN 8</b>
Portata min/max	<b>1/40 l/min - 0.26/10 GPM</b>
Pressione max. di picco	<b>450 bar - 6525 PSI</b>
Pressione max. di taratura	<b>350 bar - 5075 PSI</b>
Rapporto di pilotaggio standard	<b>4.25 : 1</b>
Temperatura ambiente	<b>-30°C + 50°C</b>
Temperatura olio	<b>-30°C + 80°C</b>
Filtraggio consigliato	<b>30 micron</b>
Coppia di serraggio	
Peso	

## PERFORMANCE

Rated size
Min/max flow-rate
Max peak pressure
Max setting pressure
Standard pilot ratio
Room temperature
Oil temperature
Recommended filtration
Tightening torque
Weight

### NOTE:

La taratura deve essere **1.3** volte maggiore della pressione indotta dal carico.

Valve should be set at **1.3** times load induced pressure.

### ESEMPIO/EXAMPLE:

Pressione di lavoro max:  
Max working pressure:  
**350 bar / 1.3 = 270 bar**

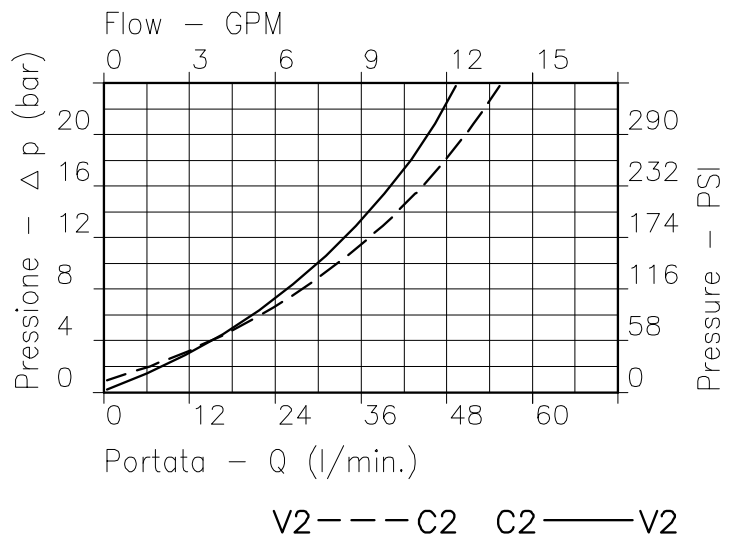

Viscosità olio 46 cSt a 50°C  
Oil viscosity 46 cSt at 50°C

REGOLAZIONE  
ADJUSTMENT →

Piombata  
Sealed

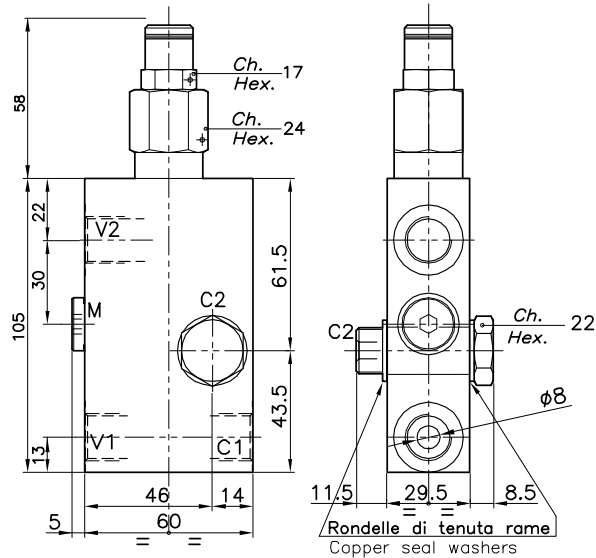

## DIMENSIONI DIMENSIONS

Campo taratura Setting range	Attacchi Port size V1-C1 V2-C2 GAS (BSPP)	Attacchi Port size M	Portata max Max flow-rate l/min - GPM
101	3/8"	1/4"	40-10

## ESEMPIO TIPICO DI CIRCUITO TYPICAL CIRCUIT EXAMPLE

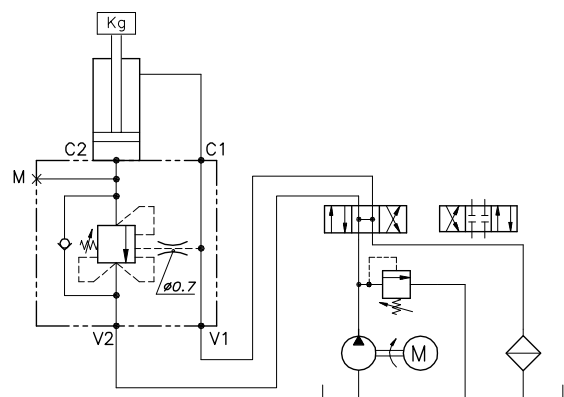

## CODICE DI ORDINAZIONE HOW TO ORDER

013 . 115 . 101 . A

Campo taratura / Setting range

101

Campo taratura 60÷350 bar (molla colore rosso)  
Setting range 60÷350 bar (red spring)

Taratura standard (Q=5 l/1')  
Std. bar setting Q=5 l/1')

250 bar

Incr. press. - bar giro/vite  
Pressure rise - turn of screw

(140)

Collettore  
Body

A Acciaio  
zincato  
Zinc plated  
steel

101

Collettore possibile in AL togliendo "A"  
Available aluminium body without "A"

# ...-OWC-SE-...-FC1-B04-...

VALVOLA BILANCIAMENTO, BLOCCO E CONTROLLO MOVIMENTO  
A SEMPLICE EFFETTO CON COLLETTORE FLANGIATO

SINGLE COUNTERBALANCE VALVE WITH FLANGEABLE BODY

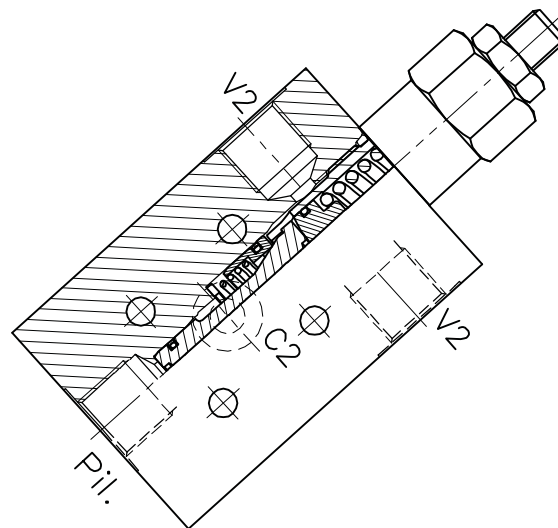
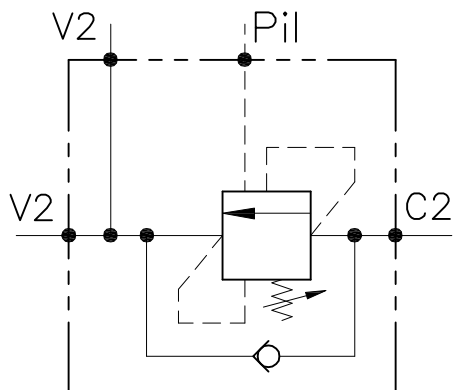

## CARATTERISTICHE

Luce nominale	<b>DN 6/8</b>
Portata min/max	<b>1/40 l/min - 0.26/10.6 GPM</b>
Pressione max. di picco	<b>450 bar - 6525 PSI</b>
Pressione max. di taratura	<b>350 bar - 5075 PSI</b>
Rapporto di pilotaggio standard	<b>4.25 : 1</b>
Temperatura ambiente	<b>-30°C + 50°C</b>
Temperatura olio	<b>-30°C + 80°C</b>
Filtraggio consigliato	<b>30 micron</b>
Coppia di serraggio	
Peso	

## PERFORMANCE

Rated size
Min/max flow-rate
Max peak pressure
Max setting pressure
Standard pilot ratio
Room temperature
Oil temperature
Recommended filtration
Tightening torque
Weight

### NOTE:

La taratura deve essere 1.3 volte maggiore della pressione indotta dal carico. Valve should be set at 1.3 times load induced pressure.

### ESEMPIO/EXAMPLE:

Pressione di lavoro max **350 bar / 1.3 = 270 bar** Max working pressure  
Fornitura standard valvola: corpo in acciaio. A richiesta corpo in alluminio. Steel body valves as standard, aluminium body on request

OWC-SE-38-FC1-B04

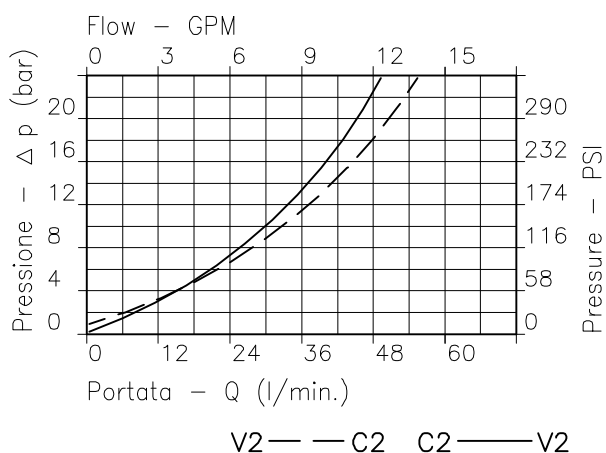

OWC-SE-14-FC1-B04

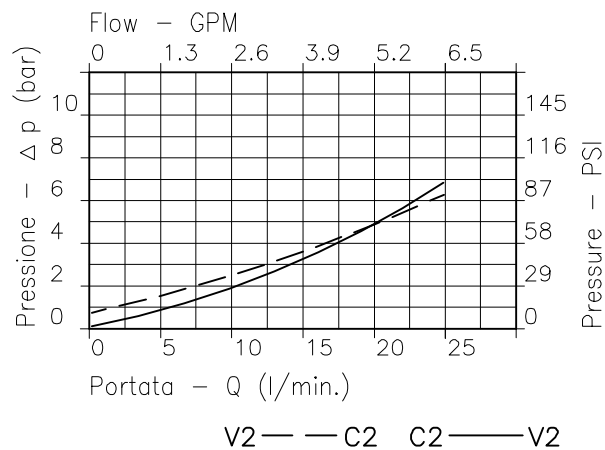

Viscosità olio 46 cSt a 50°C - Oil viscosity 46 cSt at 50°C

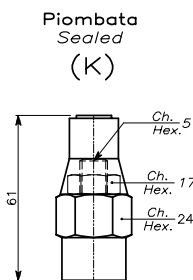
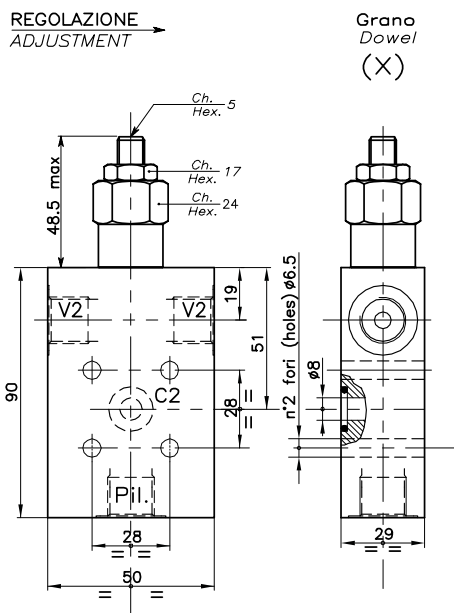

## ESEMPIO TIPICO DI CIRCUITO TYPICAL CIRCUIT EXAMPLE

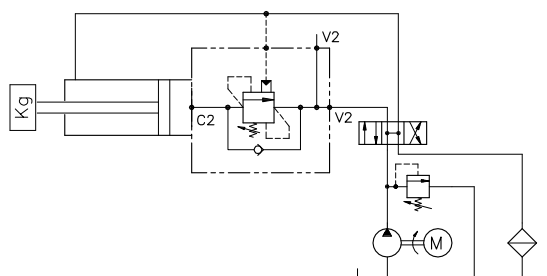

## DIMENSIONI DIMENSIONS

Campo taratura Setting range		Corpo Body	Attacchi Port size V2-C2 V1-C1 GAS (BSPP)	Luce nominale Rated size DN	Portata max Max flow-rate l/min - GPM
321	320	Acciaio Steel	1/4"	6	20-5
210	209	Acciaio Steel	3/8"	8	40-10

## CODICE DI ORDINAZIONE HOW TO ORDER

N01 . 321 . 0 X 0 . A

Campo taratura / Setting range				Rapporto di pilotaggio Pilot ratios	Regolazione Adjustment	Collettore Body
321		320		O   4.25 : 1 D   8 : 1	X   Grano - Dowel K   Piombata - Sealed	A   Acciaio zincato Zinc plated steel
210		209				
Campo taratura 30÷220 bar (molla colore verde) Setting range 30÷220 bar (green spring)		Campo taratura 60÷350 bar (molla colore giallo) Setting range 60÷350 bar (yellow spring)				
Taratura standard (Q=5 l/1')	Incr. press. - bar giro/vite	Taratura standard (Q=5 l/1')	Incr. press. - bar giro/vite			
Std. bar setting (Q=5 l/1')	Pressure rise - turn of screw	Std. bar setting (Q=5 l/1')	Pressure rise - turn of screw			
<b>180 bar</b>	<b>(50)</b>	<b>250 bar</b>	<b>(90)</b>			

# WBN-SE-F28-...

VALVOLA BILANCIAMENTO, BLOCCO E CONTROLLO MOVIMENTO  
A SEMPLICE EFFETTO CON COLLETTORE FLANGIATO

SINGLE COUNTERBALANCE VALVE WITH FLANGEABLE BODY

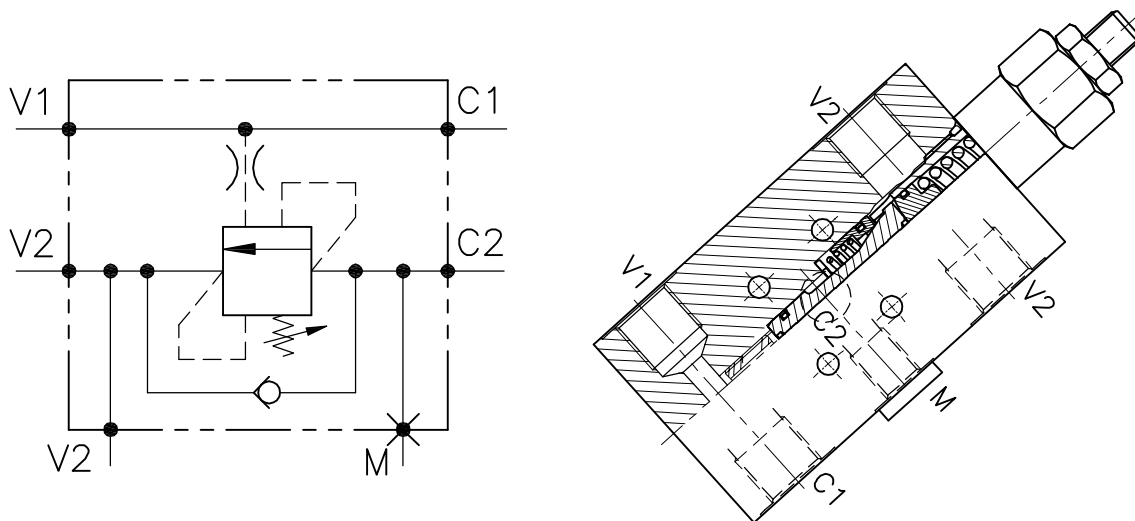

## CARATTERISTICHE

Luce nominale	<b>DN 6/8</b>
Portata min/max	<b>1/60 l/min - 0.26/15.9 GPM</b>
Pressione max. di picco	<b>450 bar - 6525 PSI</b>
Pressione max. di taratura	<b>350 bar - 5075 PSI</b>
Rapporto di pilotaggio standard	<b>4.25 : 1</b>
Temperatura ambiente	<b>-30°C + 50°C</b>
Temperatura olio	<b>-30°C + 80°C</b>
Filtraggio consigliato	<b>30 micron</b>
Coppia di serraggio	
Peso	

## PERFORMANCE

Rated size
Min/max flow-rate
Max peak pressure
Max setting pressure
Standard pilot ratio
Room temperature
Oil temperature
Recommended filtration
Tightening torque
Weight

### NOTE:

La taratura deve essere 1.3 volte maggiore della pressione indotta dal carico. Valve should be set at 1.3 times load induced pressure.

### ESEMPIO/EXAMPLE:

Pressione di lavoro max **350 bar / 1.3 = 270 bar** Max working pressure  
Fornitura standard valvola: corpo in acciaio. A richiesta corpo in alluminio. Steel body valves as standard, aluminium body on request

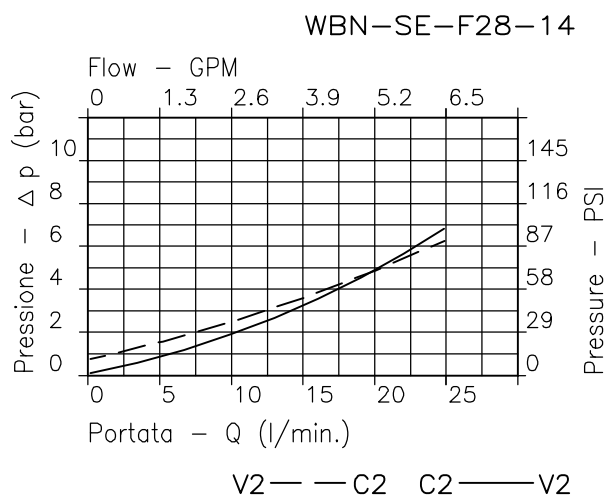
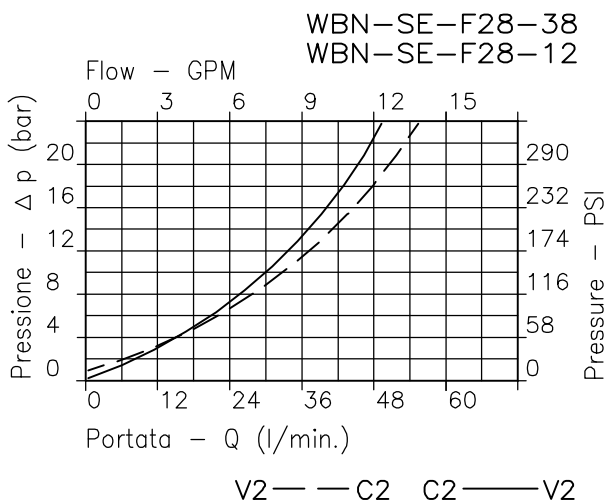

Viscosità olio 46 cSt a 50°C - Oil viscosity 46 cSt at 50°C



REGOLAZIONE  
ADJUSTMENT

Grano  
Dowel  
(X)

Piombata  
Sealed  
(K)

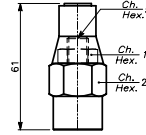
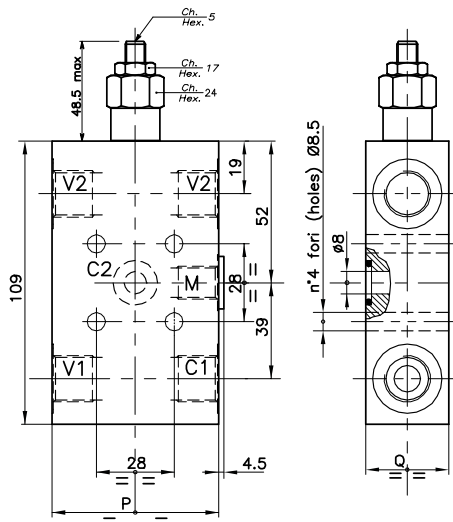

## ESEMPIO TIPICO DI CIRCUITO TYPICAL CIRCUIT EXAMPLE

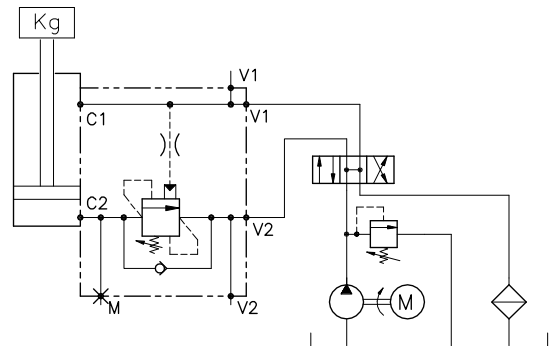

## DIMENSIONI DIMENSIONS

Campo taratura Setting range	P	Q	Attacchi Port size	Attacchi Port size	Luce nominale Rated size	Portata max Max flow-rate
			M GAS (BSPP)	V1-2-C GAS (BSPP)	DN	l/min - GPM
605	55	29	1/4"	3/8"	8	40-10
606	65	34.5	1/4"	1/2"	10	60-15

## CODICE DI ORDINAZIONE HOW TO ORDER

N01 . 605 . 0 X 0 . A

Campo taratura / Setting range

605

606

Campo taratura 60÷350 bar (molla colore giallo)  
Setting range 60÷350 bar (yellow spring)

Taratura standard (Q=5 l/1')  
Std. bar setting Q=5 l/1')

**250 bar**

Incr. press. - bar giro/vite  
Pressure rise - turn of screw

**(90)**

Rapporto di pilotaggio  
Pilot ratios

O 4.25 : 1  
D 8 : 1

Regolazione  
Adjustment

X Grano - Dowel  
K Piombata - Sealed

Collettore  
Body

A Acciaio  
zincato  
Zinc plated  
steel

# WB-DE-...FCB-...

VALVOLA BILANCIAMENTO, BLOCCO E CONTROLLO MOVIMENTO  
A DOPPIO EFFETTO CON COLLETTORE FLANGIATO

DOUBLE COUNTERBALANCE VALVE WITH FLANGEABLE BODY

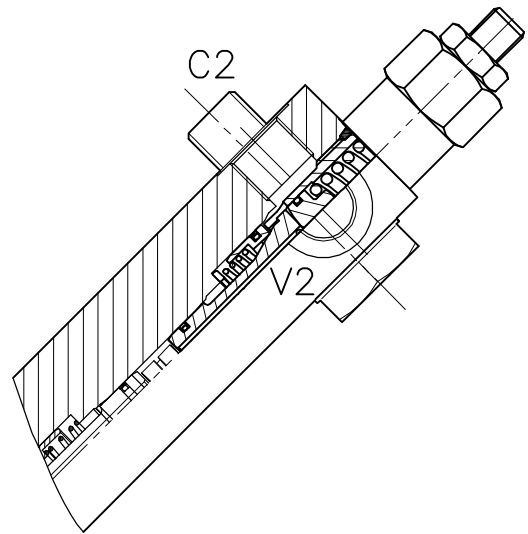
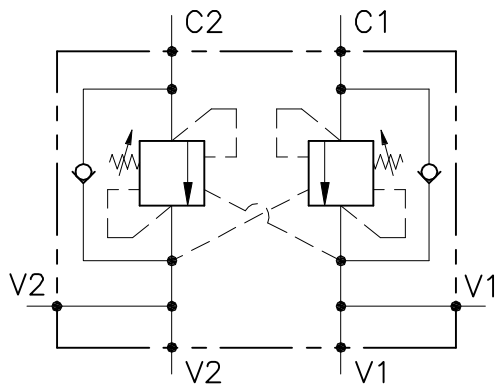

## CARATTERISTICHE

Luca nominale	<b>DN 8/10</b>
Portata min/max	<b>1/60 l/min - 0.26/15.9 GPM</b>
Pressione max. di picco	<b>450 bar - 6525 PSI</b>
Pressione max. di taratura	<b>350 bar - 5075 PSI</b>
Rapporto di pilotaggio standard	<b>4.25 : 1</b>
Temperatura ambiente	<b>-30°C + 50°C</b>
Temperatura olio	<b>-30°C + 80°C</b>
Filtraggio consigliato	<b>30 micron</b>
Peso	

## PERFORMANCE

Rated size
Min/max flow-rate
Max peak pressure
Max setting pressure
Standard pilot ratio
Room temperature
Oil temperature
Recommended filtration
Weight

### NOTE:

La taratura deve essere **1.3** volte maggiore della pressione indotta dal carico.

Valve should be set at **1.3** times load induced pressure.

### ESEMPIO/EXAMPLE:

Pressione di lavoro max:

Max working pressure:

**350 bar / 1.3 = 270 bar**

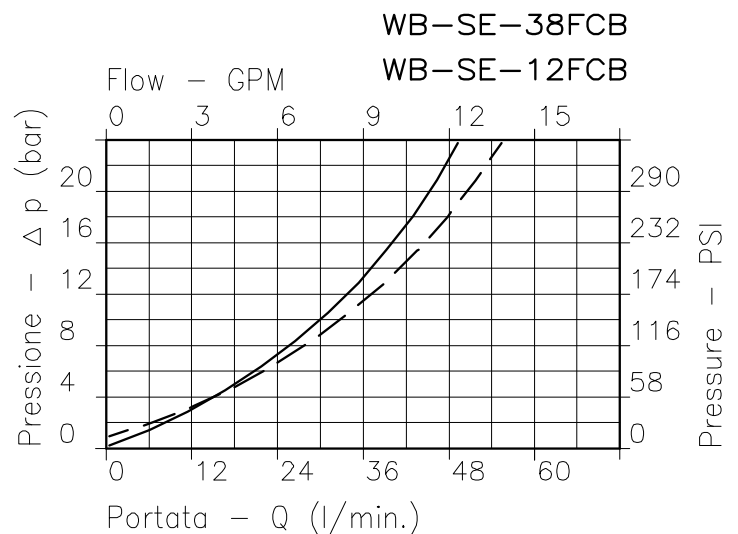

Viscosità olio 46 cSt a 50°C  
Oil viscosity 46 cSt at 50°C

REGOLAZIONE  
ADJUSTMENT →

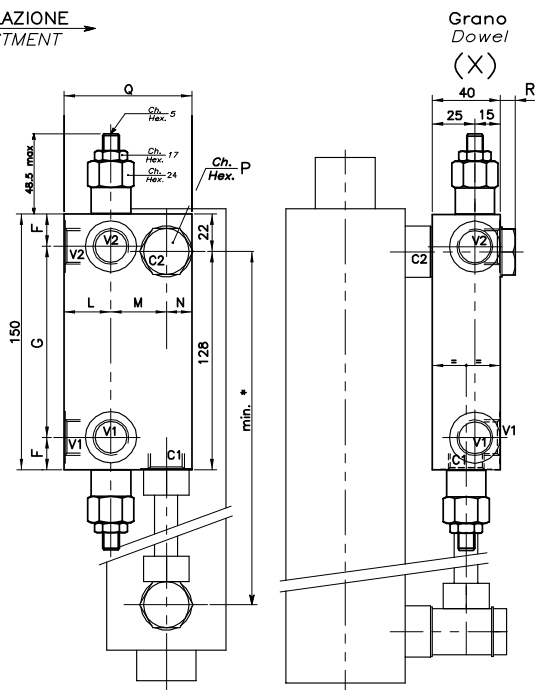

Piombata  
Sealed  
(K)

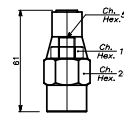

### ESEMPIO TIPICO DI CIRCUITO TYPICAL CIRCUIT EXAMPLE

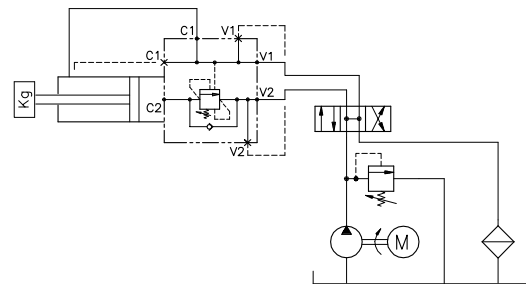

### DIMENSIONI DIMENSIONS

Campo taratura Setting range	F	G	L	M	N	P	Q	R	Attacchi Port size V1-C1 V2-C2 GAS (BSPP)	Coppia serr. Bullone Tightening torque for Bolt NM	Portata max Max flow-rate  l/min - GPM
288	21	108	25	27	13	22	65	9	3/8"	63÷71	40-10
289	19	112	27	32	16	27	72	10	1/2"	75÷85	60-15

### CODICE DI ORDINAZIONE HOW TO ORDER

N01 . 288 . 0 X 0 . A

Campo taratura / Setting range

288

289

Campo taratura 60÷350 bar (molla colore giallo)  
Setting range 60÷350 bar (yellow spring)

Taratura standard (Q=5 l/1')  
Std. bar setting Q=5 l/1')

**250 bar**

Incr. press. - bar giro/vite  
Pressure rise - turn of screw

**(90)**

Rapporto di pilotaggio  
Pilot ratios

O 4.25 : 1  
D 8 : 1

Regolazione  
Adjustment

X Grano - Dowel  
K Piombata - Sealed

Collettore  
Body

A Acciaio zincato  
Zinc plated steel

**288**

Collettore possibile in AL togliendo "A"  
Available aluminium body without "A"

# OWC-DE-...-LU-FC2-...

VALVOLA BILANCIAMENTO, BLOCCO E CONTROLLO MOVIMENTO  
A DOPPIO EFFETTO CON COLLETTORE FLANGIATO

DOUBLE COUNTERBALANCE VALVE WITH FLANGEABLE BODY

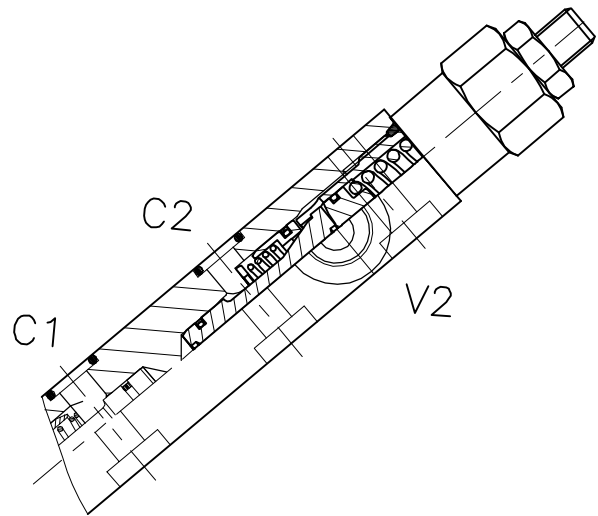
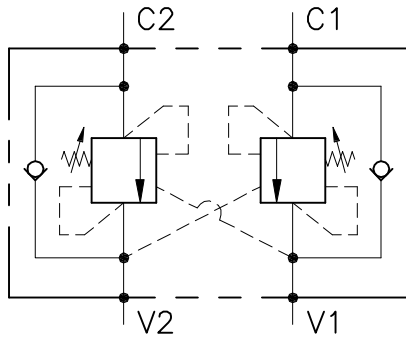

## CARATTERISTICHE

Luca nominale	<b>DN 8/10</b>
Portata min/max	<b>1/60 l/min - 0.26/15.9 GPM</b>
Pressione max. di picco	<b>350 bar - 5075 PSI</b>
Pressione max. di taratura	<b>350 bar - 5075 PSI</b>
Rapporto di pilotaggio standard	<b>Pag. 02</b>
Temperatura ambiente	<b>-30°C + 50°C</b>
Temperatura olio	<b>-30°C + 80°C</b>
Filtraggio consigliato	<b>30 micron</b>
Peso	<b>3/8" GAS 0.991 Kg</b>
Peso	<b>1/2" GAS 1.231 Kg</b>

## PERFORMANCE

Rated size
Min/max flow-rate
Max peak pressure
Max setting pressure
Standard pilot ratio
Room temperature
Oil temperature
Recommended filtration
Weight
Weight

### NOTE:

La taratura deve essere **1.3** volte maggiore della pressione indotta dal carico.

Valve should be set at **1.3** times load induced pressure.

### ESEMPIO/EXAMPLE:

Pressione di lavoro max:  
Max working pressure:  
**350 bar / 1.3 = 270 bar**

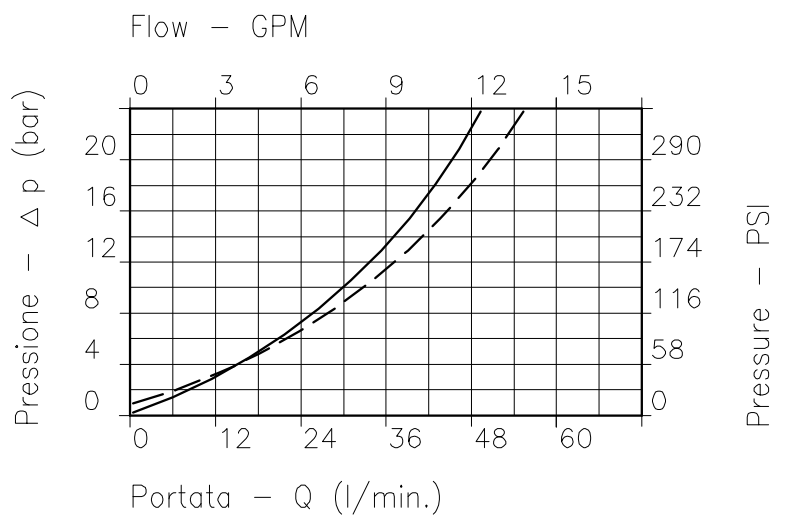

Viscosità olio 46 cSt a 50°C  
Oil viscosity 46 cSt at 50°C

REGOLAZIONE  
ADJUSTMENT

Grano  
Dowel  
(X)

Piombata  
Sealed  
(K)

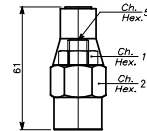
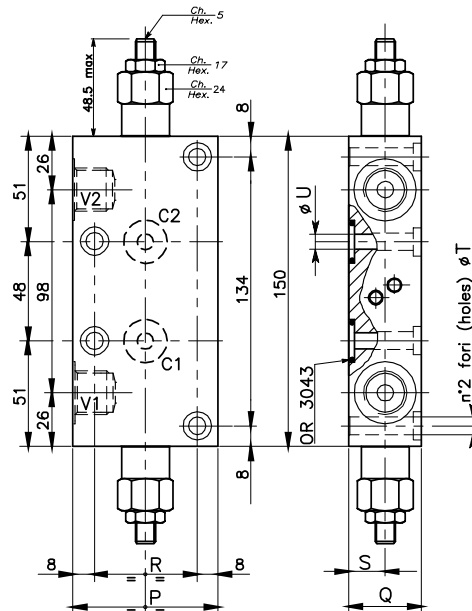

## ESEMPIO TIPICO DI CIRCUITO TYPICAL CIRCUIT EXAMPLE

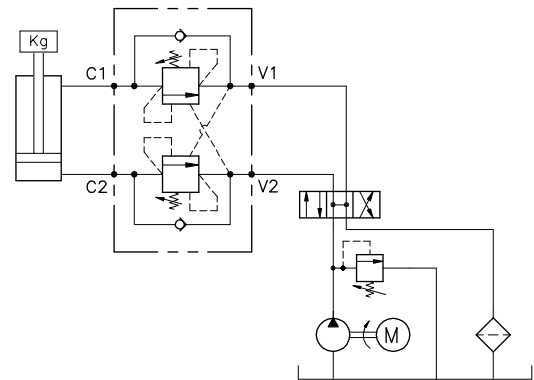

## DIMENSIONI DIMENSIONS

Campo taratura Setting range		P	Q	R	S	T	U	Attacchi Port size V2-V1 GAS (BSPP)	Luce nominale Rated size DN	Portata max Max flow-rate l/min - GPM
069	022	60	29.5	44	14.5	6.5	6	3/8"	8	40-10
070	023	70	34.5	54	17	8.5	8	1/2"	10	60-15

## CODICE DI ORDINAZIONE HOW TO ORDER

N01 . 069 . 0 X 0 . A

Campo taratura / Setting range				Rapporto di pilotaggio Pilot ratios	Regolazione Adjustment	Collettore Body	
069	022	O	4.25 : 1	X	Grano - Dowel	A	Acciaio zincato Zinc plated steel
070	023	D	8 : 1	K	Piombata - Sealed		
Campo taratura 30÷220 bar (molla colore verde) Setting range 30÷220 bar (green spring)	Campo taratura 60÷350 bar (molla colore giallo) Setting range 60÷350 bar (yellow spring)						
Taratura standard (Q=5 l/1')	Incr. press. - bar giro/vite	Taratura standard (Q=5 l/1')	Incr. press. - bar giro/vite				
Std. bar setting (Q=5 l/1')	Pressure rise - turn of screw	Std. bar setting (Q=5 l/1')	Pressure rise - turn of screw				
<b>180 bar</b>	<b>(50)</b>	<b>250 bar</b>	<b>(90)</b>				
				<b>069</b>	Collettore possibile in AL togliendo "A"		
				<b>022</b>	Available aluminium body without "A"		

# WB-DE-...-LU-FC2-OIL-...-...

VALVOLA BILANCIAMENTO, BLOCCO E CONTROLLO MOVIMENTO  
A DOPPIO EFFETTO CON COLLETTORE FLANGIATO

DOUBLE COUNTERBALANCE VALVE WITH FLANGEABLE BODY

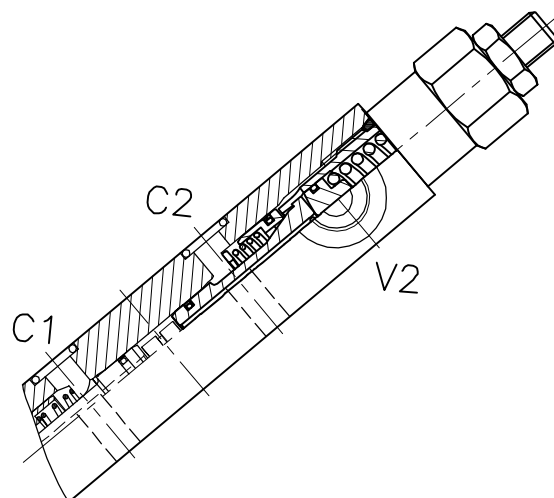
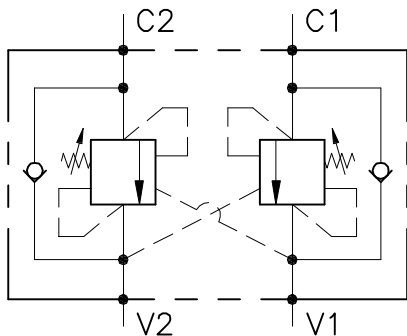

## CARATTERISTICHE

Luca nominale	<b>DN 8/10</b>
Portata min/max	<b>1/60 l/min - 0.26/15.9 GPM</b>
Pressione max. di picco	<b>350 bar - 5075 PSI</b>
Pressione max. di taratura	<b>350 bar - 5075 PSI</b>
Rapporto di pilotaggio standard	<b>4.25 : 1</b>
Temperatura ambiente	<b>-30°C + 50°C</b>
Temperatura olio	<b>-30°C + 80°C</b>
Filtraggio consigliato	<b>30 micron</b>
Peso	
Peso	

## PERFORMANCE

Rated size
Min/max flow-rate
Max peak pressure
Max setting pressure
Standard pilot ratio
Room temperature
Oil temperature
Recommended filtration
Weight
Weight

### NOTE:

La taratura deve essere **1.3** volte maggiore della pressione indotta dal carico.

Valve should be set at **1.3** times load induced pressure.

### ESEMPIO/EXAMPLE:

Pressione di lavoro max:

Max working pressure:

**350 bar / 1.3 = 270 bar**

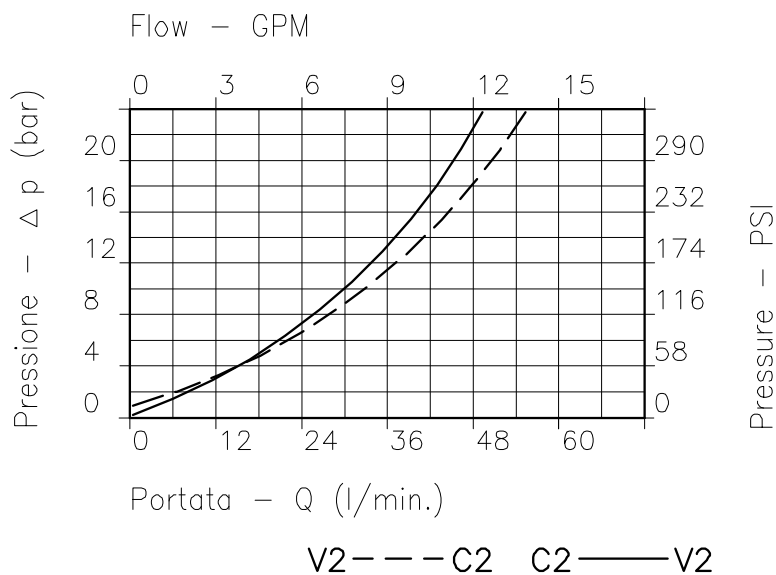

Viscosità olio 46 cSt a 50°C  
Oil viscosity 46 cSt at 50°C

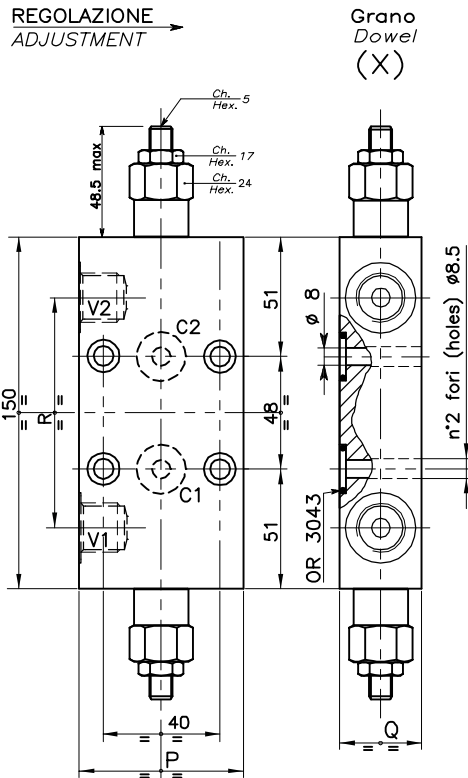

## ESEMPIO TIPICO DI CIRCUITO TYPICAL CIRCUIT EXAMPLE

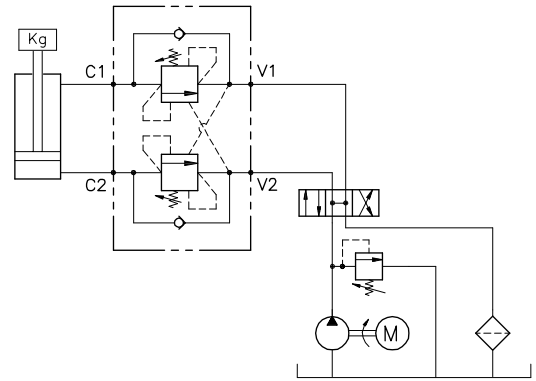

## DIMENSIONI DIMENSIONS

Campo taratura Setting range		P	Q	R	Attacchi Port size V2-V1 GAS (BSPP)	Portata max Max flow-rate l/min - GPM
047	026	55	29.5	109.5	3/8"	40-10
049	028	65	34.5	112	1/2"	60-15

## CODICE DI ORDINAZIONE HOW TO ORDER

N01 . 047 . 0 X 0 . A

Campo taratura / Setting range				Rapporto di pilotaggio Pilot ratios	Regolazione Adjustment	Collettore Body
047		026		O 4.25 : 1 D 8 : 1	X Grano - Dowel K Piombata - Sealed	A Acciaio zincato Zinc plated steel
049		028				
Campo taratura 30÷220 bar (molla colore verde) Setting range 30÷220 bar (green spring)		Campo taratura 60÷350 bar (molla colore giallo) Setting range 60÷350 bar (yellow spring)				
Taratura standard (Q=5 l/1')	Incr. press. - bar giro/vite	Taratura standard (Q=5 l/1')	Incr. press. - bar giro/vite			
Std. bar setting (Q=5 l/1')	Pressure rise - turn of screw	Std. bar setting (Q=5 l/1')	Pressure rise - turn of screw			
<b>180 bar</b>	<b>(50)</b>	<b>250 bar</b>	<b>(90)</b>			

# OWC-SE-L6-...

VALVOLA BILANCIAMENTO, BLOCCO E CONTROLLO DISCESA  
A SEMPLICE EFFETTO CON MONTAGGIO CETOP

SINGLE COUNTERBALANCE WITH SANDWICH INSTALLATION (CETOP)

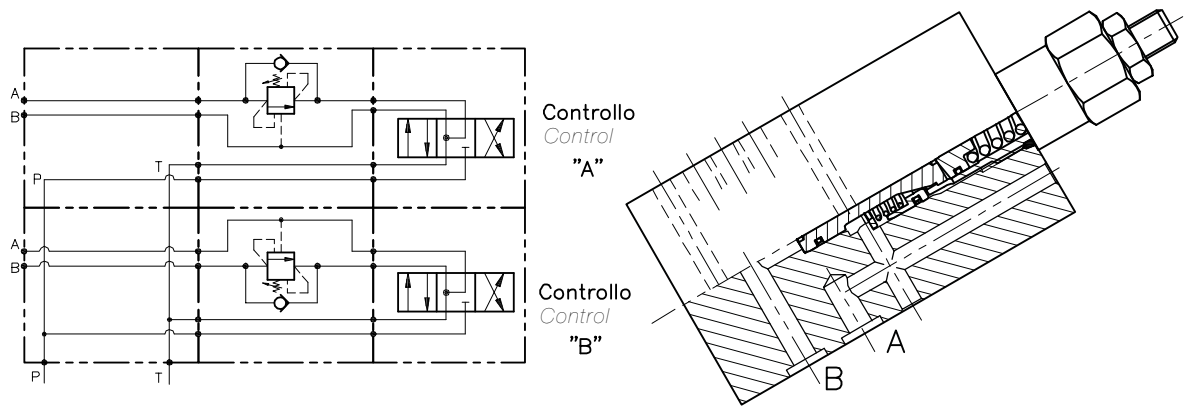

## CARATTERISTICHE

Luca nominale	
Portata min/max	<b>DN 6</b>
Pressione max. di picco	<b>1/50 l/min - 0.26/12.5 GPM</b>
Pressione max. di taratura	<b>350 bar - 5075 PSI</b>
Rapporto di pilotaggio standard	<b>350 bar - 5075 PSI</b>
Temperatura ambiente	<b>4.25 : 1</b>
Temperatura olio	<b>-30°C + 50°C</b>
Filtraggio consigliato	<b>-30°C + 80°C</b>
Peso	<b>30 micron</b>
Peso	

## PERFORMANCE

Rated size
Min/max flow-rate
Max peak pressure
Max setting pressure
Standard pilot ratio
Room temperature
Oil temperature
Recommended filtration
Weight
Weight

### NOTE:

La taratura deve essere **1.3** volte maggiore della pressione indotta dal carico.

Valve should be set at **1.3** times load induced pressure.

### ESEMPIO/EXAMPLE:

Pressione di lavoro max:  
Max working pressure:  
**350 bar / 1.3 = 270 bar**

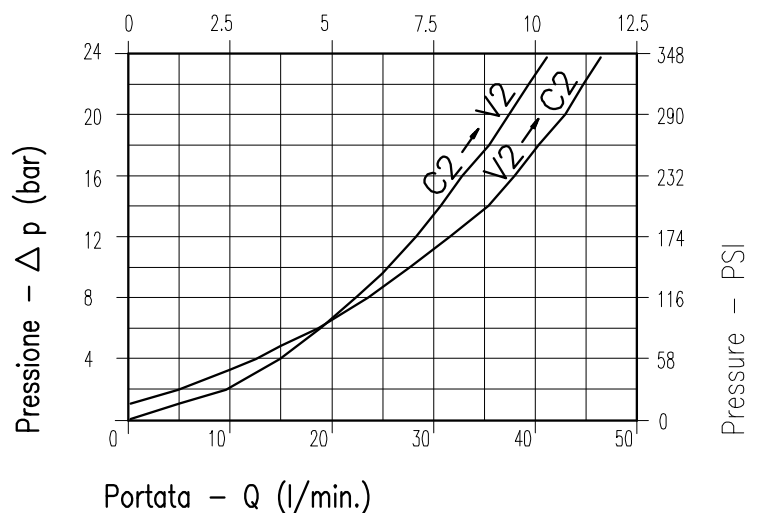

Viscosità olio 46 cSt a 50°C  
Oil viscosity 46 cSt at 50°C



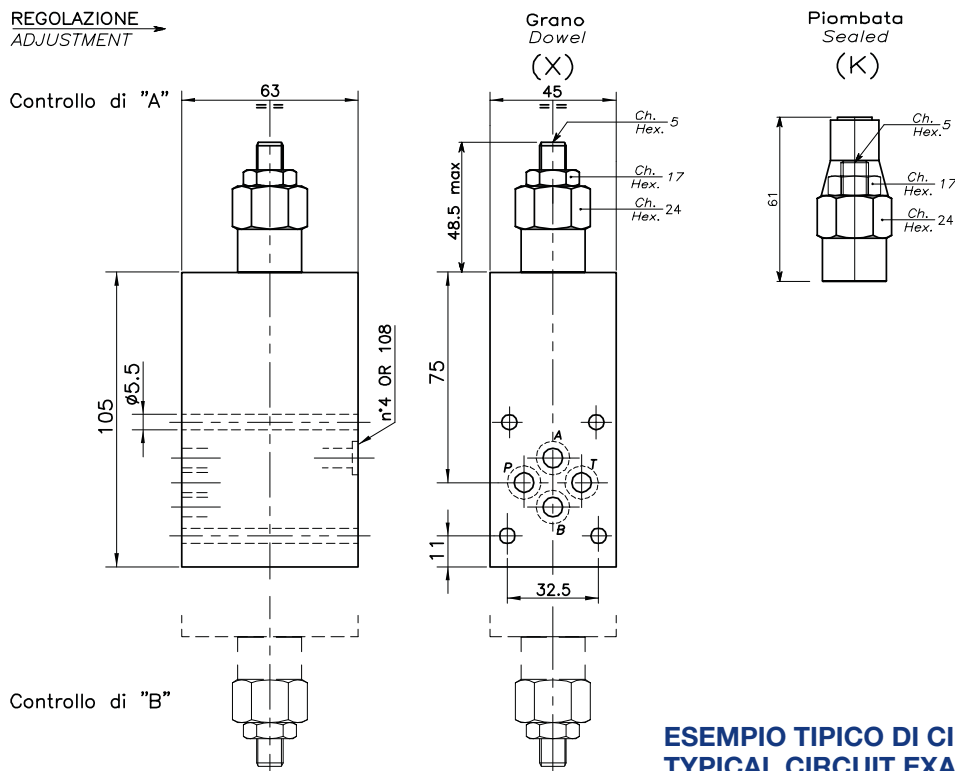

## ESEMPIO TIPICO DI CIRCUITO TYPICAL CIRCUIT EXAMPLE

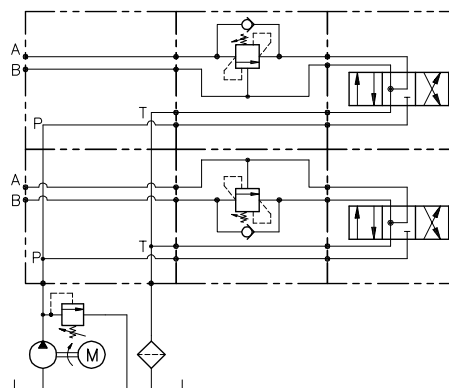

## DIMENSIONI DIMENSIONS

Campo taratura Setting range		Tipo flangia Flange type	Portata max Max flow-rate l/min - GPM	Controllo Control
229	228	CETOP 03	50-12.5	A
231	230	CETOP 03	50-12.5	B

## CODICE DI ORDINAZIONE HOW TO ORDER

N01 . 229 . 0 X 0 . A

Campo taratura / Setting range			
229		228	
231		230	
Campo taratura 30÷220 bar (molla colore verde) Setting range 30÷220 bar (green spring)		Campo taratura 60÷350 bar (molla colore giallo) Setting range 60÷350 bar (yellow spring)	
Taratura standard (Q=5 l/1')	Incr. press. - bar giro/vite	Taratura standard (Q=5 l/1')	Incr. press. - bar giro/vite
Std. bar setting (Q=5 l/1')	Pressure rise - turn of screw	Std. bar setting (Q=5 l/1')	Pressure rise - turn of screw
<b>180 bar</b>	<b>(50)</b>	<b>250 bar</b>	<b>(90)</b>

Rapporto di pilotaggio Pilot ratios	
O	4.25 : 1
D	8 : 1

Regolazione Adjustment	
X	Grano - Dowel
K	Piombata - Sealed

Collettore Body	
A	Acciaio zincato Zinc plated steel

# OWC-SE-L10-...

VALVOLA BILANCIAMENTO, BLOCCO E CONTROLLO DISCESA  
A SEMPLICE EFFETTO CON MONTAGGIO CETOP

SINGLE COUNTERBALANCE WITH SANDWICH INSTALLATION (CETOP)

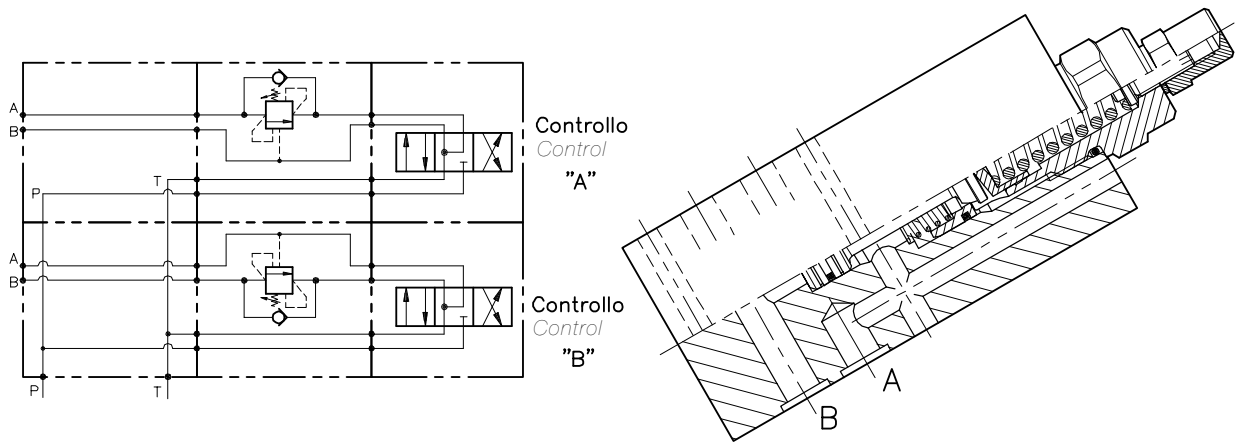

## CARATTERISTICHE

Luce nominale	<b>DN 8/10</b>
Portata min/max	<b>1/90 l/min - 0.26/24 GPM</b>
Pressione max. di picco	<b>350 bar - 5075 PSI</b>
Pressione max. di taratura	<b>350 bar - 5075 PSI</b>
Rapporto di pilotaggio standard	<b>6.2 : 1</b>
Temperatura ambiente	<b>-30°C + 50°C</b>
Temperatura olio	<b>-30°C + 80°C</b>
Filtraggio consigliato	<b>30 micron</b>
Peso	
Peso	

## PERFORMANCE

Rated size
Min/max flow-rate
Max peak pressure
Max setting pressure
Standard pilot ratio
Room temperature
Oil temperature
Recommended filtration
Weight
Weight

### NOTE:

La taratura deve essere **1.3** volte maggiore della pressione indotta dal carico.

Valve should be set at **1.3** times load induced pressure.

### ESEMPIO/EXAMPLE:

Pressione di lavoro max:  
Max working pressure:  
**350 bar / 1.3 = 270 bar**

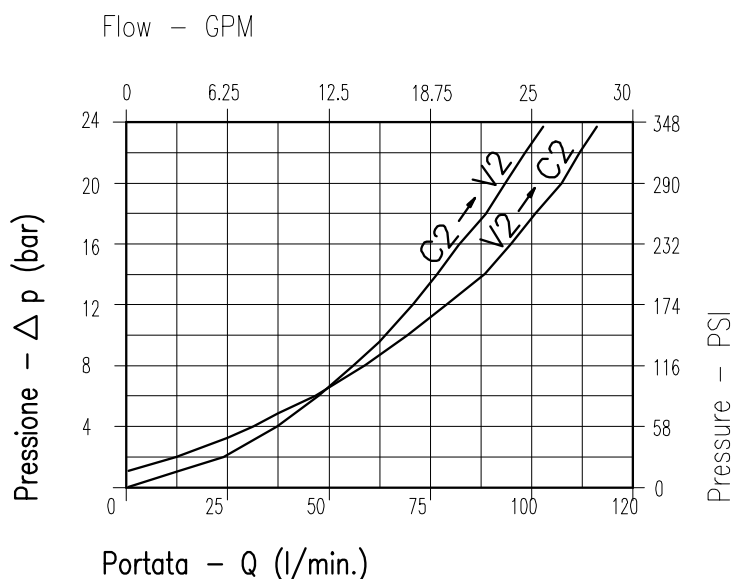

Viscosità olio 46 cSt a 50°C  
Oil viscosity 46 cSt at 50°C

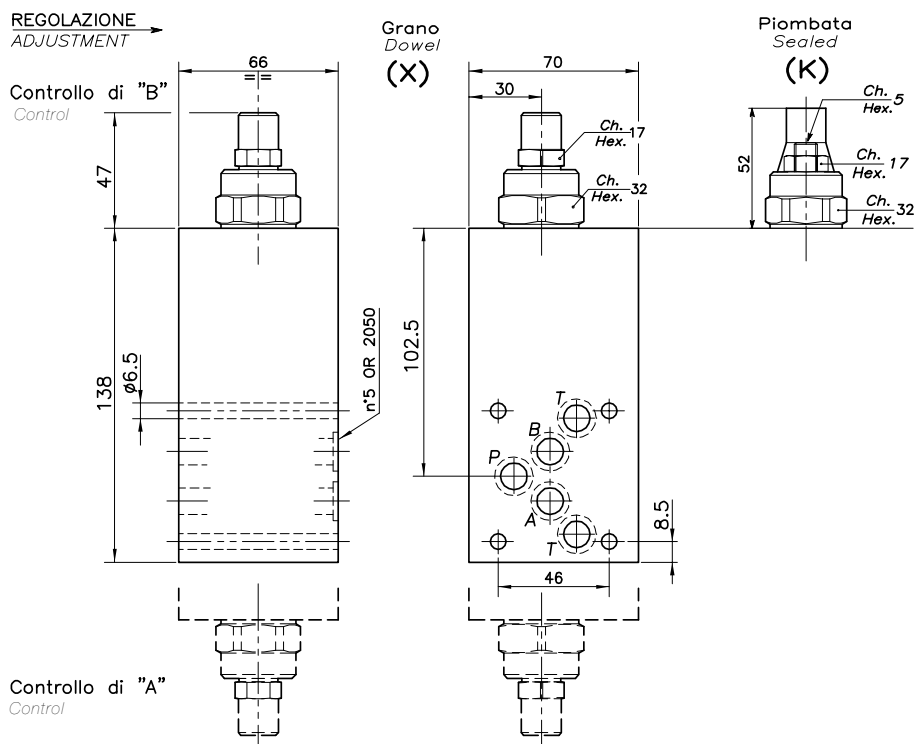

**ESEMPIO TIPICO DI CIRCUITO**  
**TYPICAL CIRCUIT EXAMPLE**

**DIMENSIONI**  
**DIMENSIONS**

Campo taratura Setting range	Tipo flangia Flange type	Portata max Max flow-rate l/min - GPM	Controllo Control
483	CETOP 05	90-24	A
484	CETOP 05	90-24	B

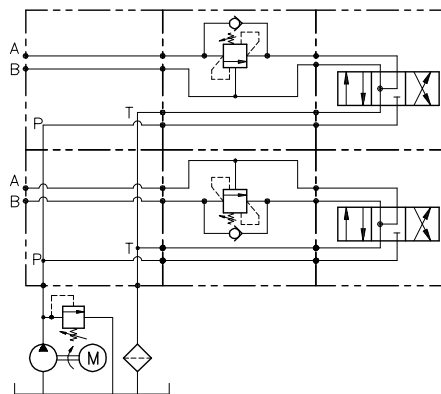

**CODICE DI ORDINAZIONE**  
**HOW TO ORDER**

001 . 483 . 0 X 0 . A

Campo taratura / Setting range
483
484

Campo taratura 60÷350 bar (molla colore giallo)  
Setting range 60÷350 bar (yellow spring)

Taratura standard (Q=5 l/1')  
Std. bar setting Q=5 l/1')

**250 bar**

Incr. press. - bar giro/vite  
Pressure rise - turn of screw  
**(125)**

Rapporto di pilotaggio  
Pilot ratios

O | 6.2 : 1

Regolazione  
Adjustment

X	Grano - Dowel
K	Piombata - Sealed

Collettore  
Body

A	Acciaio zincato Zinc plated steel
---	--------------------------------------

# OWC-DE-L6-...

VALVOLA BILANCIAMENTO, BLOCCO E CONTROLLO DISCESA  
A SEMPLICE EFFETTO CON MONTAGGIO CETOP

SINGLE COUNTERBALANCE WITH SANDWICH INSTALLATION (CETOP)

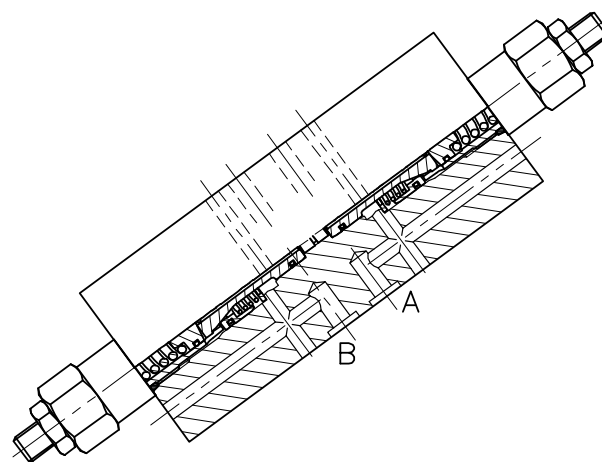
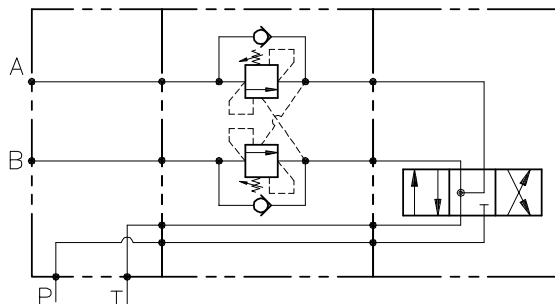

## CARATTERISTICHE

Luce nominale	<b>DN 6</b>
Portata min/max	<b>1/50 l/min - 0.26/12.5 GPM</b>
Pressione max. di picco	<b>350 bar - 5075 PSI</b>
Pressione max. di taratura	<b>350 bar - 5075 PSI</b>
Rapporto di pilotaggio standard	<b>4.25 : 1</b>
Temperatura ambiente	<b>-30°C + 50°C</b>
Temperatura olio	<b>-30°C + 80°C</b>
Filtraggio consigliato	<b>30 micron</b>
Peso	
Peso	

## PERFORMANCE

Rated size
Min/max flow-rate
Max peak pressure
Max setting pressure
Standard pilot ratio
Room temperature
Oil temperature
Recommended filtration
Weight
Weight

### NOTE:

La taratura deve essere **1.3** volte maggiore della pressione indotta dal carico.

Valve should be set at **1.3** times load induced pressure.

### ESEMPIO/EXAMPLE:

Pressione di lavoro max:

Max working pressure:

**350 bar / 1.3 = 270 bar**

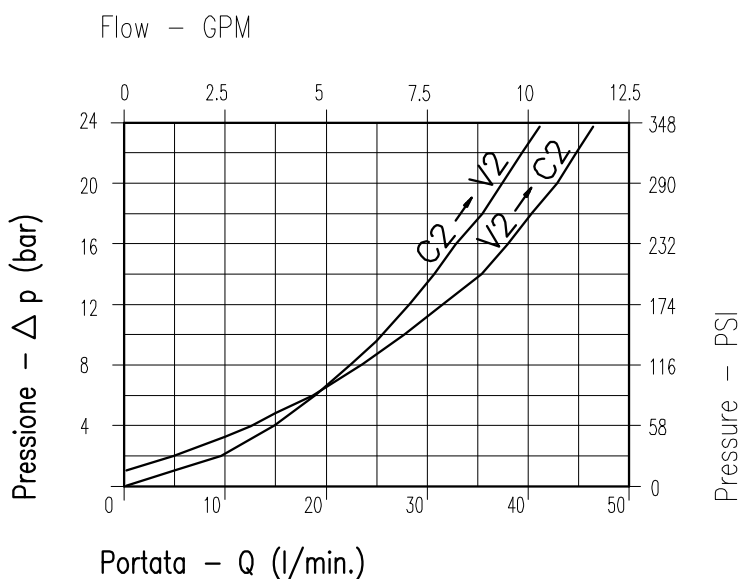

Viscosità olio 46 cSt a 50°C  
Oil viscosity 46 cSt at 50°C

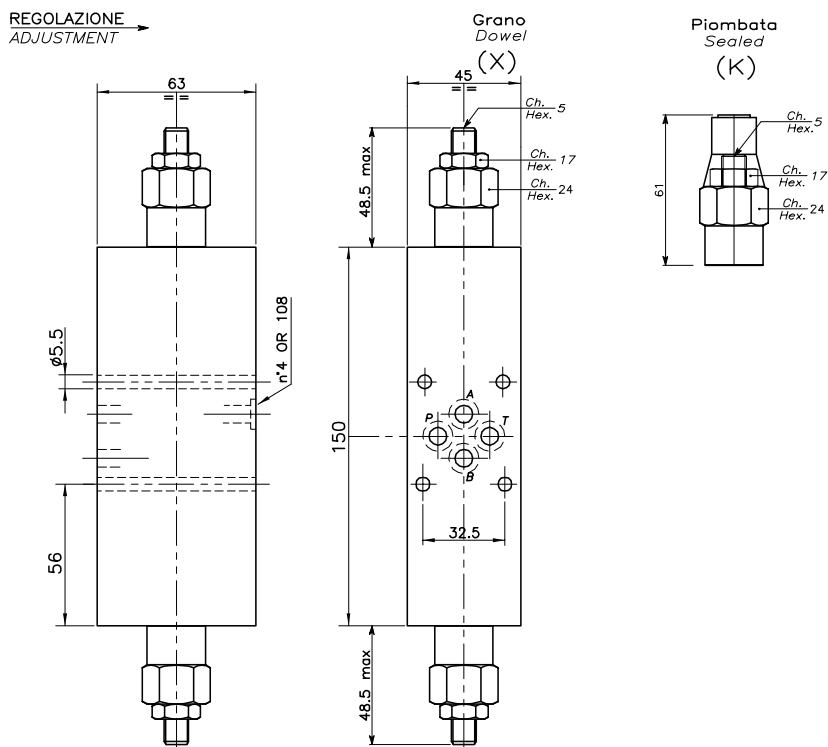

## DIMENSIONI DIMENSIONS

## ESEMPIO TIPICO DI CIRCUITO TYPICAL CIRCUIT EXAMPLE

Campo taratura Setting range	Tipo flangia Flange type	Portata max Max flow-rate l/min - GPM
226	CETOP 03	50-12.5

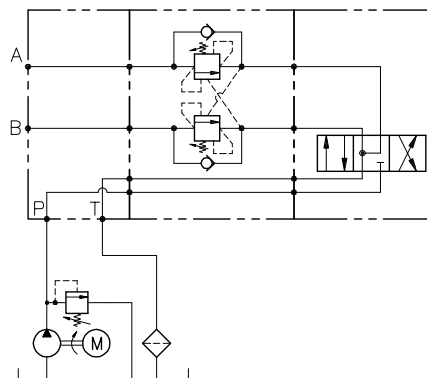

## CODICE DI ORDINAZIONE HOW TO ORDER

N01 . 226 . 0 X 0 . A

Campo taratura / Setting range <b>226</b>		Rapporto di pilotaggio Pilot ratios O   4.25 : 1	Regolazione Adjustment X   Grano - Dowel K   Piombata - Sealed	Collettore Body A   Acciaio zincato Zinc plated steel
Campo taratura 60÷350 bar (molla colore giallo) Setting range 60÷350 bar (yellow spring)				
Taratura standard (Q=5 l/1') Std. bar setting Q=5 l/1')	Incr. press. - bar giro/vite Pressure rise - turn of screw			
<b>250 bar</b>	<b>(90)</b>			
		<b>226</b>	Collettore possibile in AL togliendo "A" Available aluminium body without "A"	

# OWC-DE-L10-...

VALVOLA BILANCIAMENTO, BLOCCO E CONTROLLO DISCESA  
A SEMPLICE EFFETTO CON MONTAGGIO CETOP

SINGLE COUNTERBALANCE WITH SANDWICH INSTALLATION (CETOP)

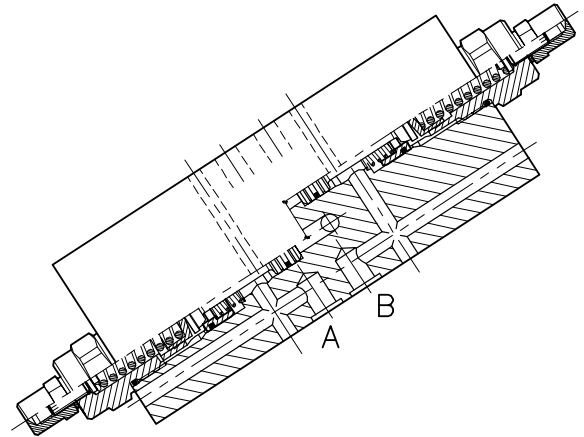
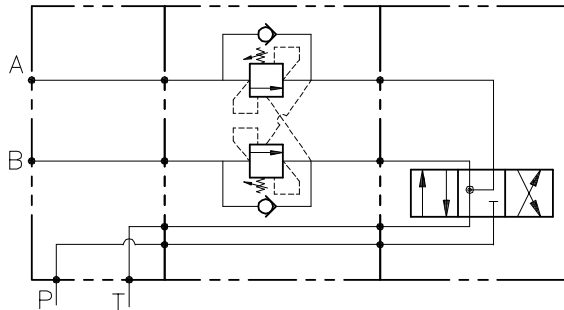

## CARATTERISTICHE

Luca nominale	<b>DN 12</b>
Portata min/max	<b>1/90 l/min - 0.26/24 GPM</b>
Pressione max. di picco	<b>350 bar - 5075 PSI</b>
Pressione max. di taratura	<b>350 bar - 5075 PSI</b>
Rapporto di pilotaggio standard	<b>6.2 : 1</b>
Temperatura ambiente	<b>-30°C + 50°C</b>
Temperatura olio	<b>-30°C + 80°C</b>
Filtraggio consigliato	<b>30 micron</b>
Peso	
Peso	

## PERFORMANCE

Rated size
Min/max flow-rate
Max peak pressure
Max setting pressure
Standard pilot ratio
Room temperature
Oil temperature
Recommended filtration
Weight
Weight

### NOTE:

La taratura deve essere **1.3** volte maggiore della pressione indotta dal carico.

Valve should be set at **1.3** times load induced pressure.

### ESEMPIO/EXAMPLE:

Pressione di lavoro max:

Max working pressure:

**350 bar / 1.3 = 270 bar**

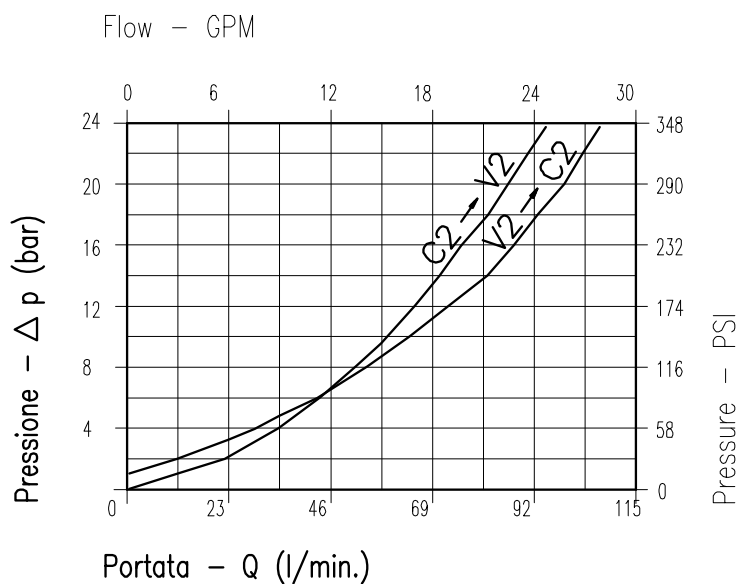

Viscosità olio 46 cSt a 50°C  
Oil viscosity 46 cSt at 50°C

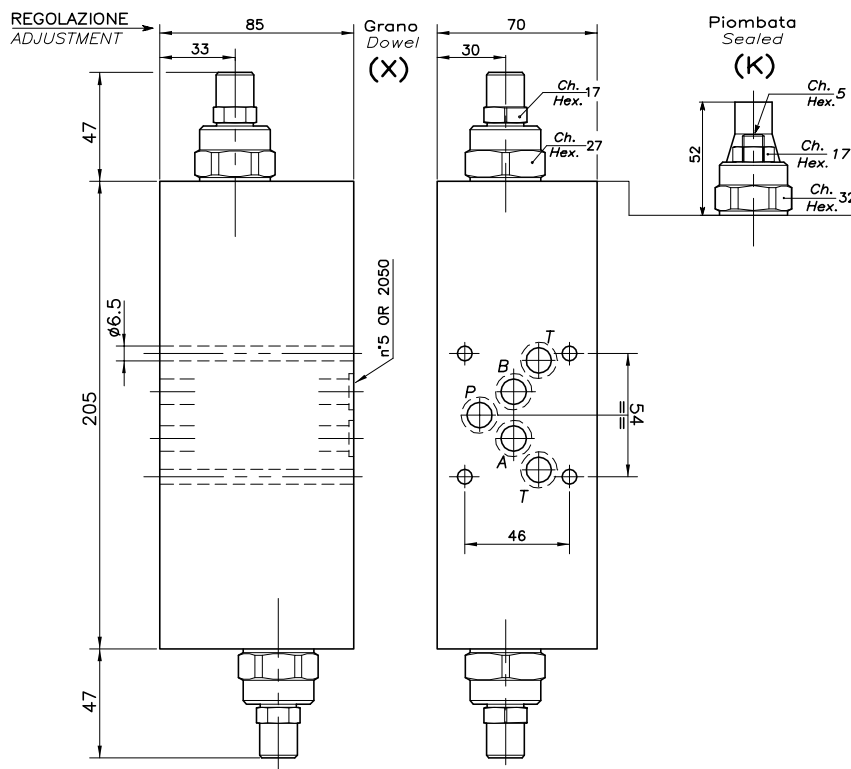

## DIMENSIONI DIMENSIONS

## ESEMPIO TIPICO DI CIRCUITO TYPICAL CIRCUIT EXAMPLE

Campo taratura Setting range	Tipo flangia Flange type	Portata max Max flow-rate l/min - GPM
292	CETOP 05	90-24

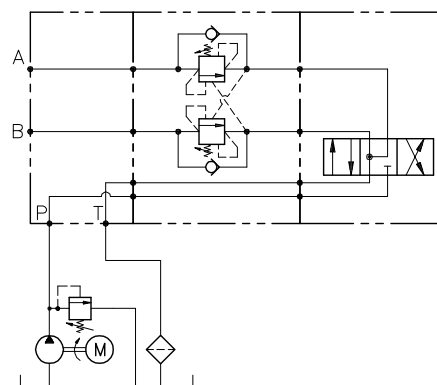

## CODICE DI ORDINAZIONE HOW TO ORDER

001 . 292 . 0 X 0 . A

Campo taratura / Setting range 292		Rapporto di pilotaggio Pilot ratios O   6.2 : 1	Regolazione Adjustment X   Grano - Dowel K   Piombata - Sealed	Collettore Body A   Acciaio zincato Zinc plated steel
Campo taratura 60÷350 bar (molla colore giallo) Setting range 60÷350 bar (yellow spring)				
Taratura standard (Q=5 l/1') Std. bar setting Q=5 l/1')	Incr. press. - bar giro/vite Pressure rise - turn of screw (125)			
250 bar				

# WB-M-SE-VFF-...-12-14-...

VALVOLA BILANCIAMENTO, BLOCCO E CONTROLLO MOVIMENTO  
A SEMPLICE EFFETTO FLANGIATA MOTORE

SINGLE COUNTERBALANCE MOTOR FLANGEABLE VALVE

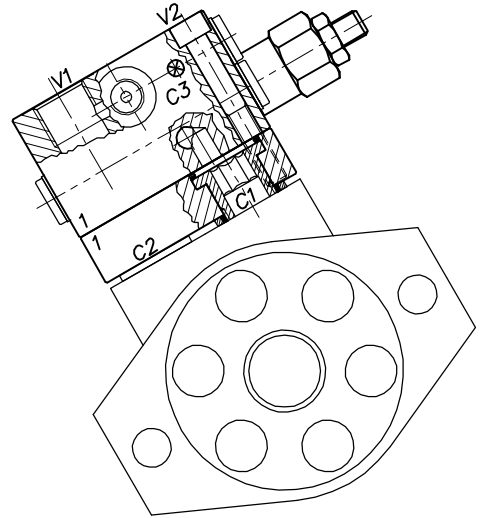
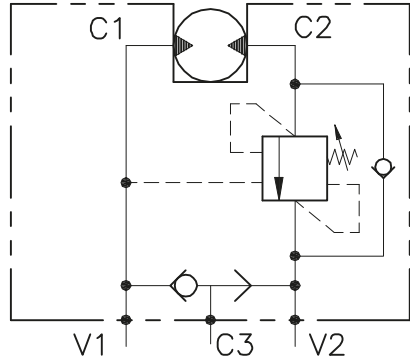

## CARATTERISTICHE

Luce nominale	<b>DN 12</b>
Portata min/max	<b>1/60 l/min - 0.26/15.9 GPM</b>
Pressione max. di picco	<b>350 bar - 5075 PSI</b>
Pressione max. di taratura	<b>350 bar - 5075 PSI</b>
Rapporto di pilotaggio standard	<b>4.25 : 1</b>
Temperatura ambiente	<b>-30°C + 50°C</b>
Temperatura olio	<b>-30°C + 80°C</b>
Filtraggio consigliato	<b>30 micron</b>
Coppia di serraggio	<b>110÷115 Nm</b>
Peso	

## PERFORMANCE

Rated size
Min/max flow-rate
Max peak pressure
Max setting pressure
Standard pilot ratio
Room temperature
Oil temperature
Recommended filtration
Tightening torque
Weight

### NOTE:

La taratura deve essere **1.3** volte maggiore della pressione indotta dal carico.

Valve should be set at **1.3** times load induced pressure.

### ESEMPIO/EXAMPLE:

Pressione di lavoro max:  
Max working pressure:  
**350 bar / 1.3 = 270 bar**

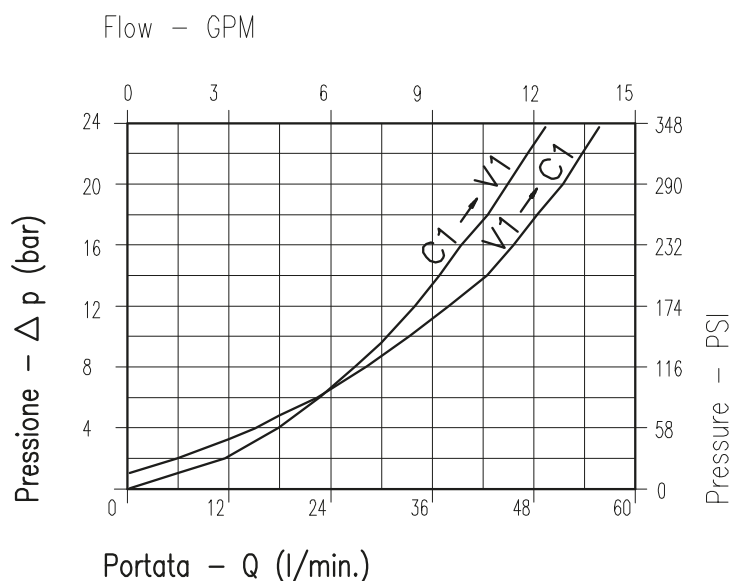

Viscosità olio 46 cSt a 50°C  
Oil viscosity 46 cSt at 50°C



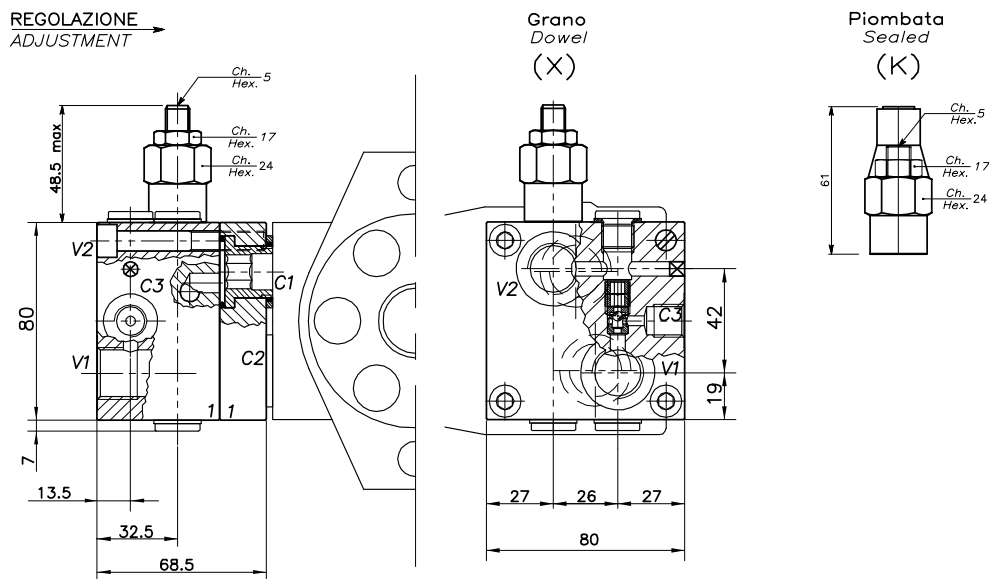

## DIMENSIONI DIMENSIONS

## ESEMPIO TIPICO DI CIRCUITO TYPICAL CIRCUIT EXAMPLE

Campo taratura Setting range		Attacchi Port size V2-C2 V1-C1 GAS (BSPP)	Attacchi Port size C3 GAS (BSPP)	Tipo motore Motor type
533	126	1/2"	1/4"	Samhydraulik HPR-HPRC Danfoss OMS (32x2)
534		1/2"	1/4"	Olidrive (32x22)
535		1/2"	1/4"	Danfoss OMR-OMP (36x36)
545		1/2"	1/4"	TRW MAC/MAF (45,7)
618	668	1/2"	1/4"	Samhydraulik AG-BG-AR (40x8)

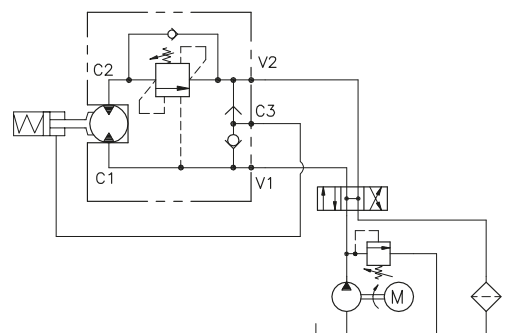

## CODICE DI ORDINAZIONE HOW TO ORDER

N01 . 533 . 0 X 0 . A

Campo taratura / Setting range			
533	126		
534			
535			
545			
618	668		
Campo taratura 30÷220 bar (molla colore verde) Setting range 30÷220 bar (green spring)		Campo taratura 60÷350 bar (molla colore giallo) Setting range 60÷350 bar (yellow spring)	
Taratura standard (Q=5 l/1')	Incr. press. - bar giro/vite	Taratura standard (Q=5 l/1')	Incr. press. - bar giro/vite
Std. bar setting (Q=5 l/1')	Pressure rise - turn of screw	Std. bar setting (Q=5 l/1')	Pressure rise - turn of screw
<b>180 bar</b>	<b>(50)</b>	<b>250 bar</b>	<b>(90)</b>

Rapporto di pilotaggio Pilot ratios	
O	4.25 : 1
D	8 : 1

Regolazione Adjustment	
X	Grano - Dowel
K	Piombata - Sealed

Collettore Body	
A	Acciaio zincato Zinc plated steel

# OWC-SE-VFF-...-14-FMV2-...

VALVOLA BILANCIAMENTO, BLOCCO E CONTROLLO MOVIMENTO  
A SEMPLICE EFFETTO FLANGIATA MOTORE

SINGLE COUNTERBALANCE MOTOR FLANGEABLE VALVE

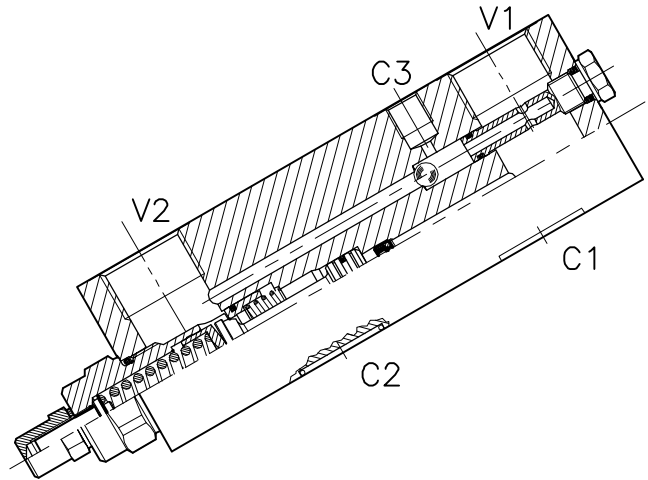
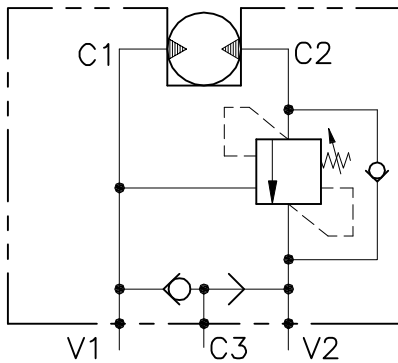

## CARATTERISTICHE

Luca nominale	<b>DN 15</b>
Portata min/max	<b>1/180 l/min - 0.26/47 GPM</b>
Pressione max. di picco	<b>350 bar - 5075 PSI</b>
Pressione max. di taratura	<b>350 bar - 5075 PSI</b>
Rapporto di pilotaggio standard	<b>6.2 : 1</b>
Temperatura ambiente	<b>-30°C + 50°C</b>
Temperatura olio	<b>-30°C + 80°C</b>
Filtraggio consigliato	<b>30 micron</b>
Coppia di serraggio	
Peso	

## PERFORMANCE

Rated size
Min/max flow-rate
Max peak pressure
Max setting pressure
Standard pilot ratio
Room temperature
Oil temperature
Recommended filtration
Tightening torque
Weight

### NOTE:

La taratura deve essere **1.3** volte maggiore della pressione indotta dal carico.

Valve should be set at **1.3** times load induced pressure.

### ESEMPIO/EXAMPLE:

Pressione di lavoro max:

Max working pressure:

**350 bar / 1.3 = 270 bar**

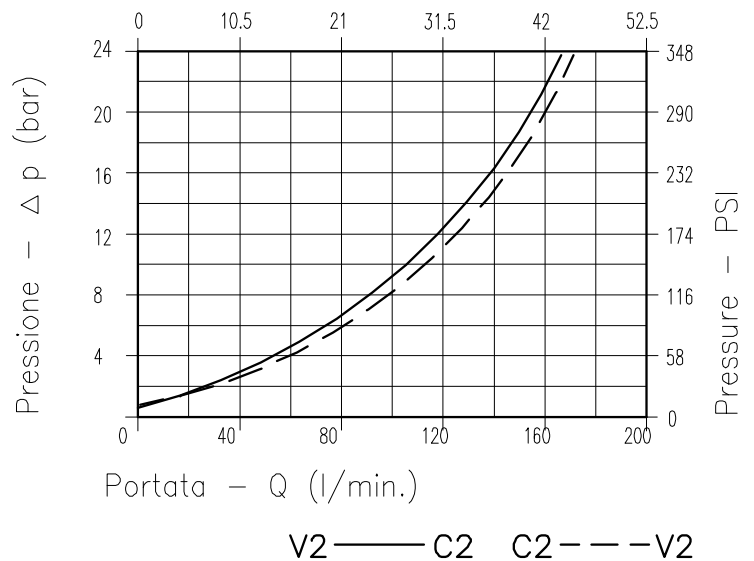

Viscosità olio 46 cSt a 50°C  
Oil viscosity 46 cSt at 50°C

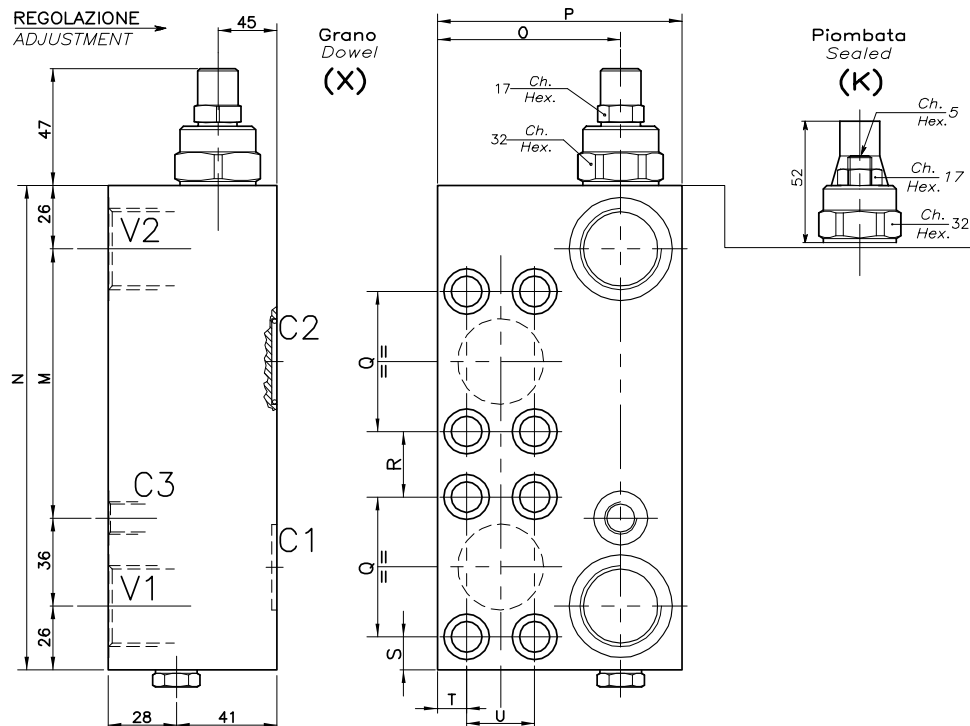

## DIMENSIONI DIMENSIONS

Campo taratura Setting range	M	N	O	P	Q	R	S	T	U	Attacchi Port size C1-C2	Attacchi Port size V1-V2 GAS (BSPP)	Attacchi Port size C3 GAS (BSPP)	Tipo Motore Motor type
564	110	198	75	100	57.2	26.8	13.4	12	27.8	Ø 15	1"	1/4"	H1CR 90-108 HMT (84)
565	95	183	65	90	50.8	24.2	11	13	23.8	Ø 15	3/4"	1/4"	H1CR 45-55-75 HMT (75)
566	67	155	55	80	40.6	18.4	9	9	18.2	Ø 15	1/2"	1/4"	H1CR 20-30 HMT (59)

## CODICE DI ORDINAZIONE HOW TO ORDER

001 . 564 . 0 X 0 . A

Campo taratura / Setting range		Rapporto di pilotaggio Pilot ratios		Regolazione Adjustment		Collettore Body	
564		O 6.2 : 1		X Grano - Dowel		A Acciaio zincato Zinc plated steel	
565		G 4.1 : 1		K Piombata - Sealed			
566							
Campo taratura 60÷350 bar (molla colore giallo) Setting range 60÷350 bar (yellow spring)							
Taratura standard (Q=5 l/1') Std. bar setting Q=5 l/1')							
250 bar							
		Incr. press. - bar giro/vite Pressure rise - turn of screw					
		(125)					

# OWC-SE-12-FMD-G-...

VALVOLA BILANCIAMENTO, BLOCCO E CONTROLLO MOVIMENTO  
A SEMPLICE EFFETTO FLANGIATA MOTORE

SINGLE COUNTERBALANCE MOTOR FLANGEABLE VALVE

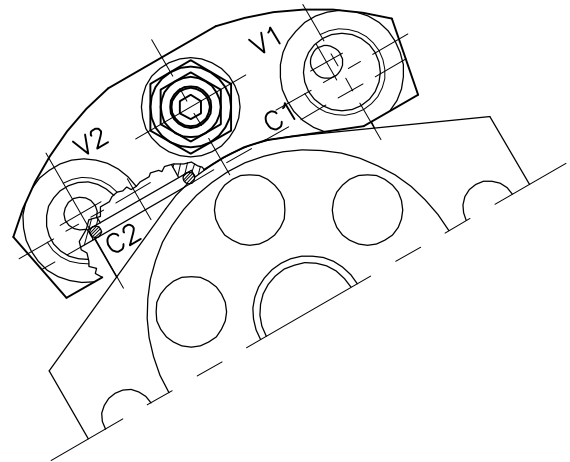
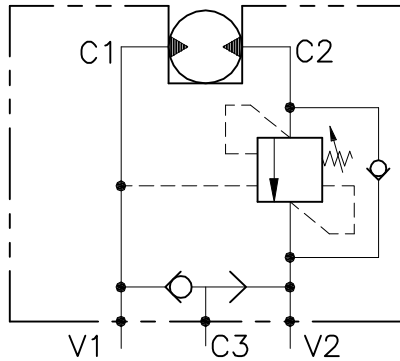

## CARATTERISTICHE

Luce nominale	<b>DN 10</b>
Portata min/max	<b>1/60 l/min - 0.26/15.9 GPM</b>
Pressione max. di picco	<b>350 bar - 5075 PSI</b>
Pressione max. di taratura	<b>220 bar - 3190 PSI</b>
Rapporto di pilotaggio standard	<b>4.25 : 1</b>
Temperatura ambiente	<b>-30°C + 50°C</b>
Temperatura olio	<b>-30°C + 80°C</b>
Filtraggio consigliato	<b>30 micron</b>
Coppia di serraggio	
Peso	

## PERFORMANCE

Rated size
Min/max flow-rate
Max peak pressure
Max setting pressure
Standard pilot ratio
Room temperature
Oil temperature
Recommended filtration
Tightening torque
Weight

### NOTE:

La taratura deve essere **1.3** volte maggiore della pressione indotta dal carico.

Valve should be set at **1.3** times load induced pressure.

### ESEMPIO/EXAMPLE:

Pressione di lavoro max:

Max working pressure:

**350 bar / 1.3 = 270 bar**

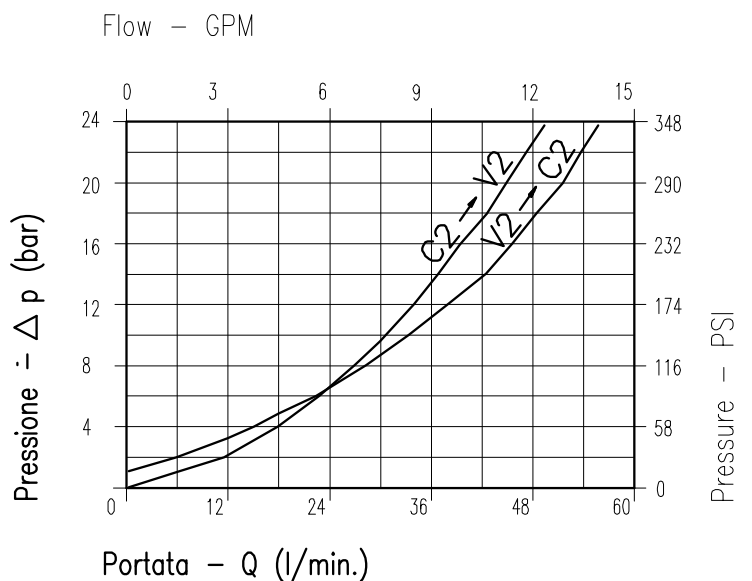

Viscosità olio 46 cSt a 50°C  
Oil viscosity 46 cSt at 50°C

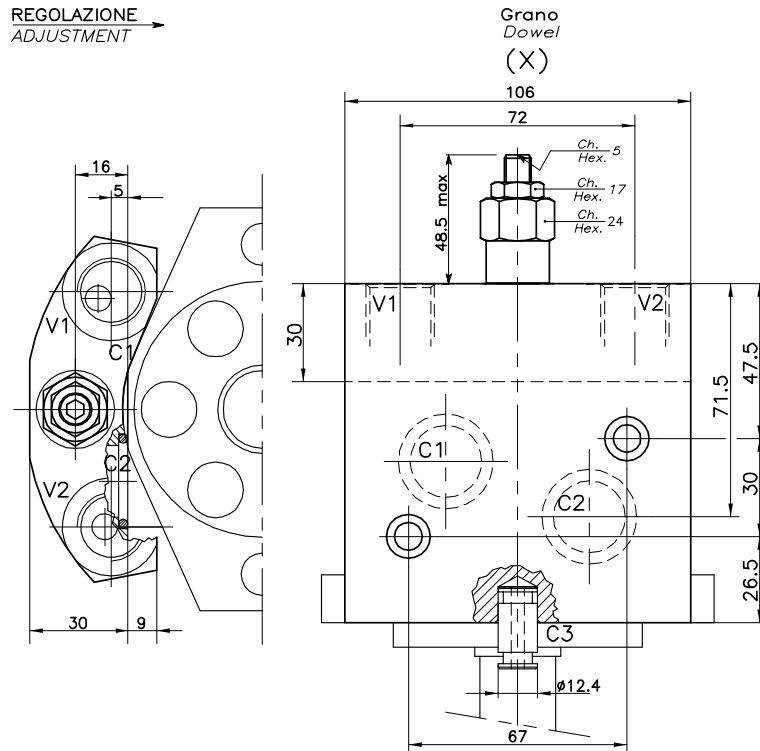

## DIMENSIONI DIMENSIONS

Campo taratura Setting range	Attacchi Port size V1-C1 GAS (BSPP)	Attacchi Port size C3 GAS (BSPP)	Tipo motore Motor type Oildrive (44x17)	Portata max Max flow-rate l/min - GPM
202	1/2"	Ø12	Oildrive (44x17)	60-15

## ESEMPIO TIPICO DI CIRCUITO TYPICAL CIRCUIT EXAMPLE

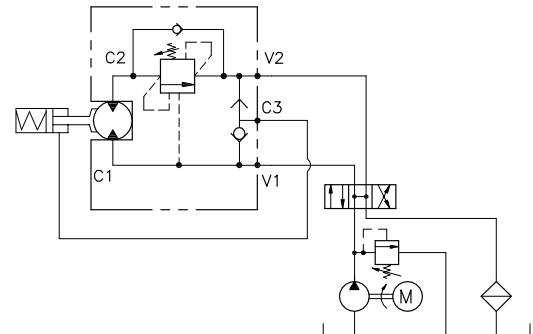

## CODICE DI ORDINAZIONE HOW TO ORDER

N01 . 202 . 0 X 0	
Campo taratura / Setting range	
202	
Campo taratura 30÷220 bar (molla colore verde) Setting range 30÷22 0 bar (green spring)	
Taratura standard (Q=5 l/1') Std. bar setting (Q=5 l/1')	Incr. press. - bar giro/vite Pressure rise - turn of screw
180 bar	(50)
Rapporto di pilotaggio Pilot ratios	Regolazione Adjustment
0   4.25 : 1	X   Grano - Dowel

# OWC-DE-VFF-...-14-FMV2-...

VALVOLA BILANCIAMENTO, BLOCCO E CONTROLLO MOVIMENTO  
A DOPPIO EFFETTO FLANGIATA MOTORE

SINGLE COUNTERBALANCE MOTOR FLANGEABLE VALVE

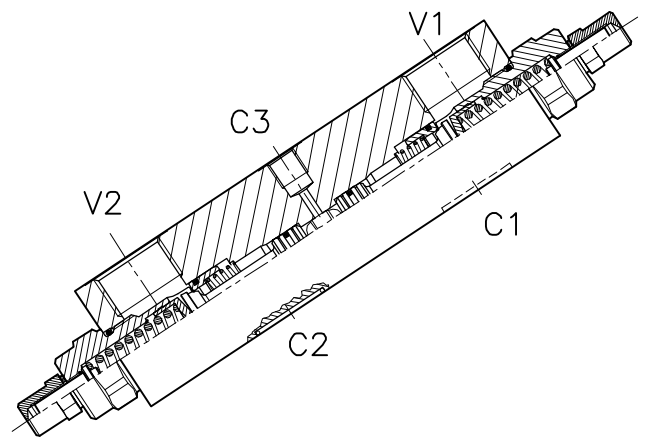
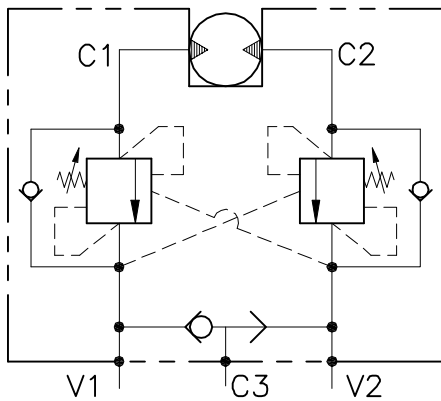

## CARATTERISTICHE

Luce nominale	<b>DN 15</b>
Portata min/max	<b>1/180 l/min - 0.26/47 GPM</b>
Pressione max. di picco	<b>350 bar - 5075 PSI</b>
Pressione max. di taratura	<b>350 bar - 5075 PSI</b>
Rapporto di pilotaggio standard	<b>6.2 : 1</b>
Temperatura ambiente	<b>-30°C + 50°C</b>
Temperatura olio	<b>-30°C + 80°C</b>
Filtraggio consigliato	<b>30 micron</b>
Coppia di serraggio	
Peso	

## PERFORMANCE

Rated size
Min/max flow-rate
Max peak pressure
Max setting pressure
Standard pilot ratio
Room temperature
Oil temperature
Recommended filtration
Tightening torque
Weight

### NOTE:

La taratura deve essere **1.3** volte maggiore della pressione indotta dal carico.

Valve should be set at **1.3** times load induced pressure.

### ESEMPIO/EXAMPLE:

Pressione di lavoro max:

Max working pressure:

**350 bar / 1.3 = 270 bar**

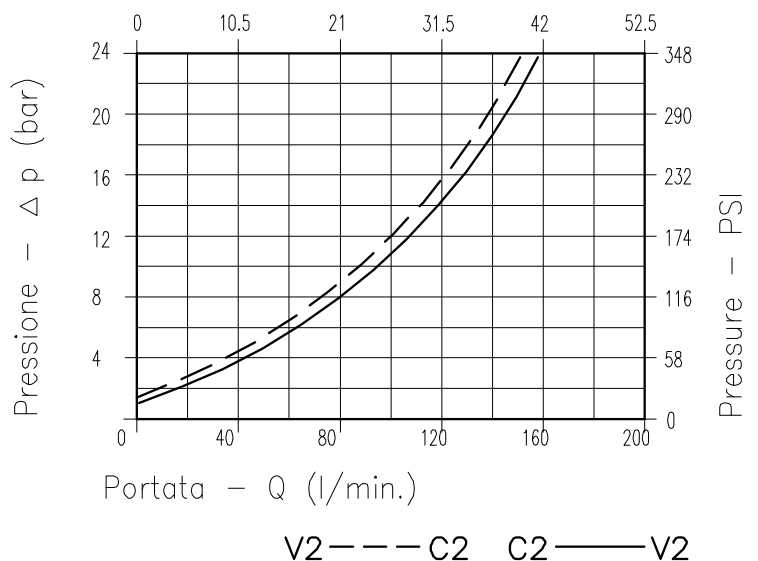

Viscosità olio 46 cSt a 50°C  
Oil viscosity 46 cSt at 50°C

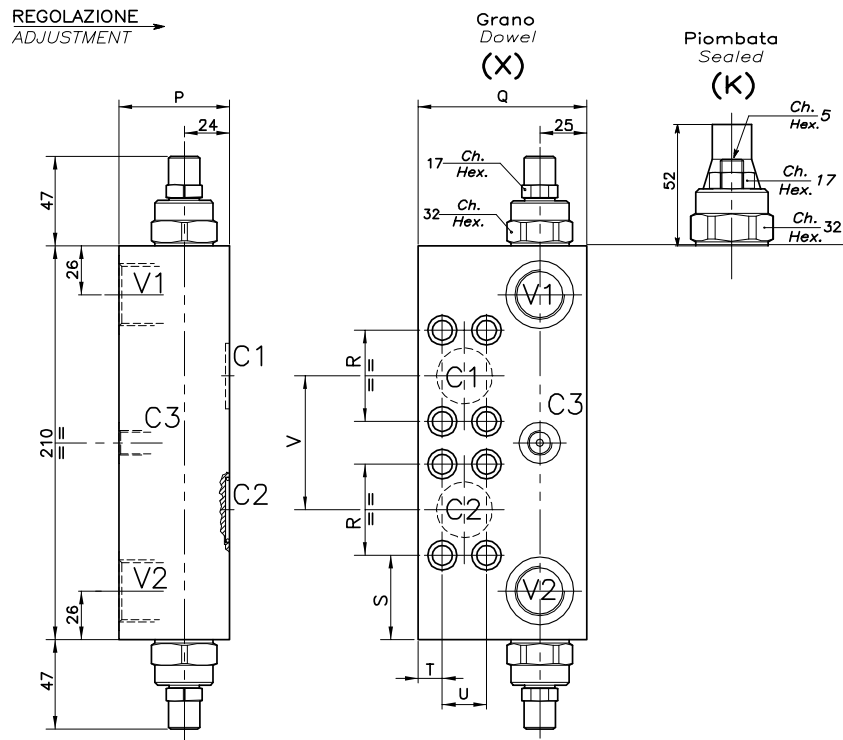

## DIMENSIONI DIMENSIONS

Campo taratura Setting range	P	Q	R	S	T	U	V	Attacchi	Attacchi	Attacchi	Tipo Motore Motor type	Portata max Max flow-rate l/min - GPM
								Port size C1-C2	Port size V1-V2 GAS (BSPP)	Port size C3 GAS (BSPP)		
094	69	100	57.2	34.4	12	27.8	84	Ø 15	1"	1/4"	H1CR 90-108 HMT (84)	180-47
101	59	90	50.8	42.1	13	23.8	75	Ø 15	3/4"	1/4"	H1CR 45-55-75 HMT (75)	120-31
095	59	80	55.2	55.2	16.8	18.2	59	Ø 15	1/2"	1/4"	H1CR 20-30 HMT (59)	70-18

## CODICE DI ORDINAZIONE HOW TO ORDER

001 . 094 . 0 X 0 . A

Campo taratura / Setting range		Rapporto di pilotaggio Pilot ratios		Regolazione Adjustment		Collettore Body	
094		O 6.2 : 1		X Grano - Dowel		A Acciaio zincato Zinc plated steel	
101		G 4.1 : 1		K Piombata - Sealed			
095							
Campo taratura 60÷350 bar (molla colore giallo) Setting range 60÷350 bar (yellow spring)							
Taratura standard (Q=5 l/1') Std. bar setting Q=5 l/1')		Incr. press. - bar giro/vite Pressure rise - turn of screw					
250 bar		(125)					

# OWC-DE-VFF-...-14-FHV2-...

VALVOLA BILANCIAMENTO, BLOCCO E CONTROLLO MOVIMENTO  
A DOPPIO EFFETTO FLANGIATA MOTORE

SINGLE COUNTERBALANCE MOTOR FLANGEABLE VALVE

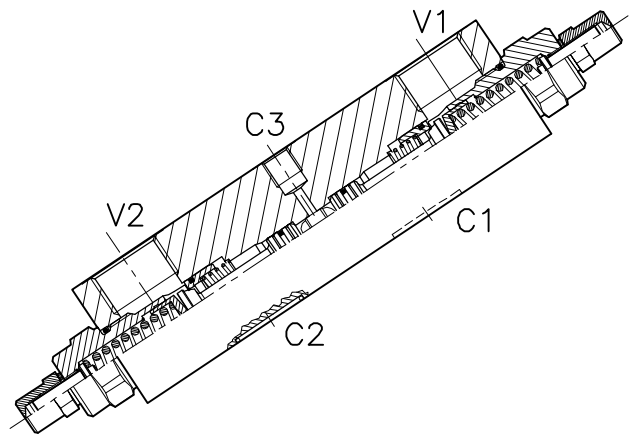
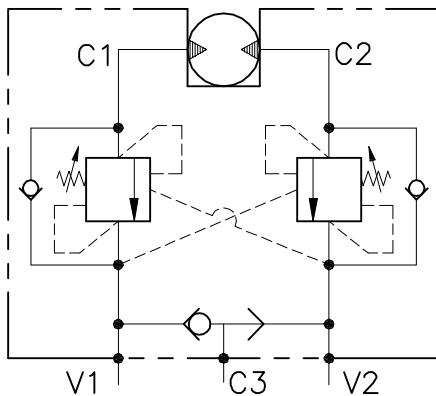

## CARATTERISTICHE

Luce nominale	<b>DN 15</b>
Portata min/max	<b>10/180 l/min - 2.5/47 GPM</b>
Pressione max. di picco	<b>350 bar - 5075 PSI</b>
Pressione max. di taratura	<b>350 bar - 5075 PSI</b>
Rapporto di pilotaggio standard	<b>6.2 : 1</b>
Temperatura ambiente	<b>-30°C + 50°C</b>
Temperatura olio	<b>-30°C + 80°C</b>
Filtraggio consigliato	<b>30 micron</b>
Coppia di serraggio	
Peso	

## PERFORMANCE

Rated size
Min/max flow-rate
Max peak pressure
Max setting pressure
Standard pilot ratio
Room temperature
Oil temperature
Recommended filtration
Tightening torque
Weight

### NOTE:

La taratura deve essere **1.3** volte maggiore della pressione indotta dal carico.

Valve should be set at **1.3** times load induced pressure.

### ESEMPIO/EXAMPLE:

Pressione di lavoro max:

Max working pressure:

**350 bar / 1.3 = 270 bar**

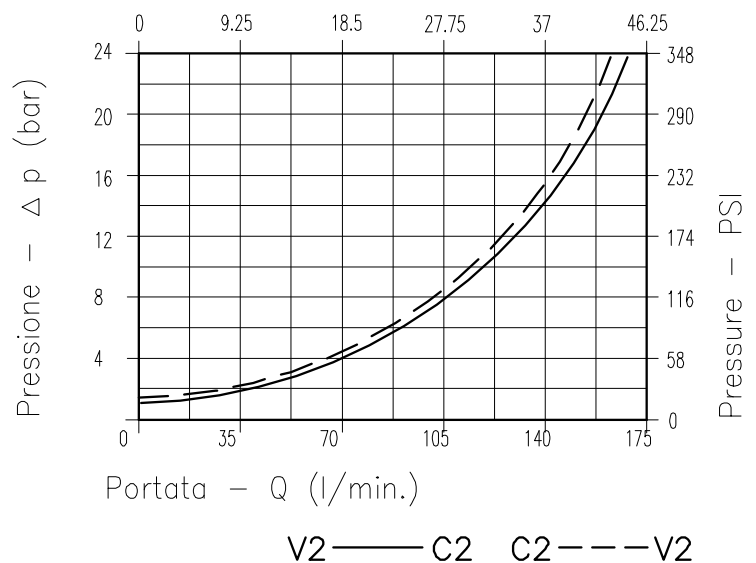

Viscosità olio 46 cSt a 50°C  
Oil viscosity 46 cSt at 50°C



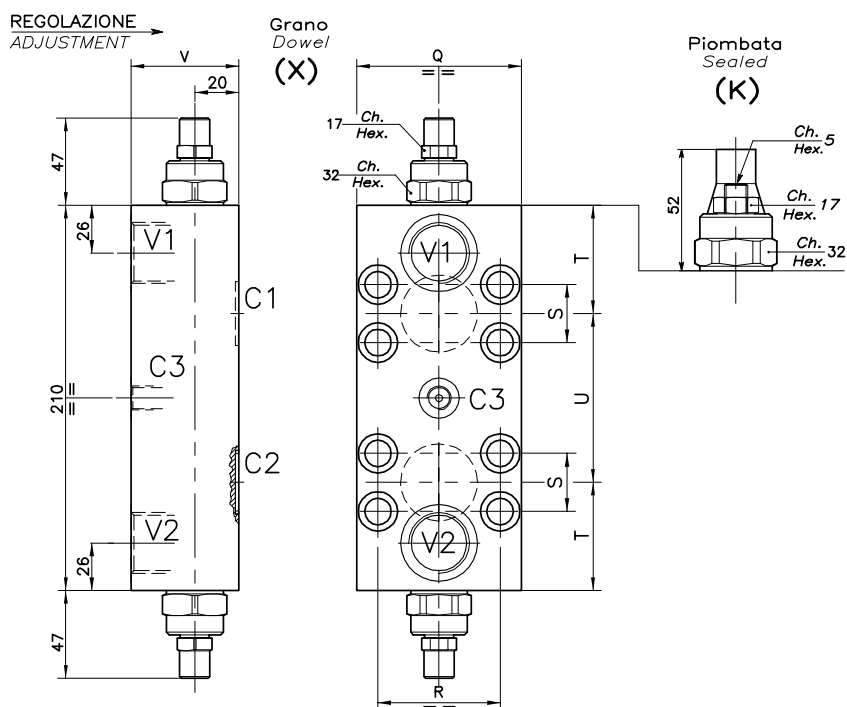

## DIMENSIONI / DIMENSIONS

Campo taratura / Setting range	Q	R	S	T	U	V	Attacchi Port size	Attacchi Port size	Attacchi Port size	Tipo Motore / Motor type	Portata max / Max flow-rate
							C1-C2 GAS (BSPP)	V1-V2 GAS (BSPP)	C3 GAS (BSPP)		
104	70	50.8	23.8	69	72	49	Ø 15	3/4"	1/4"	H2V 55	120-31
102	80	57.2	27.8	64	82	59	Ø 15	1"	1/4"	H2V 75-108	160-42
103	90	66.7	31.6	59	92	59	Ø 15	1"	1/4"	H2V 160-226	180-47

## CODICE DI ORDINAZIONE / HOW TO ORDER

001 . 104 . 0 X 0 . A

Campo taratura / Setting range
104
102
103
Campo taratura 60÷350 bar (molla colore giallo) Setting range 60÷350 bar (yellow spring)

Rapporto di pilotaggio / Pilot ratios
O 6.2 : 1
G 4.1 : 1

Regolazione / Adjustment
X Grano - Dowel
K Piombata - Sealed

Collettore / Body
A Acciaio zincato / Zinc plated steel

Taratura standard (Q=5 l/1')  
Std. bar setting Q=5 l/1')

250 bar

Incr. press. - bar giro/vite  
Pressure rise - turn of screw

(125)

# WB-M-DE-VFF-...-12-14-...

VALVOLA BILANCIAMENTO, BLOCCO E CONTROLLO MOVIMENTO  
A DOPPIO EFFETTO FLANGIATA MOTORE

DOUBLE COUNTERBALANCE MOTOR FLANGEABLE VALVE

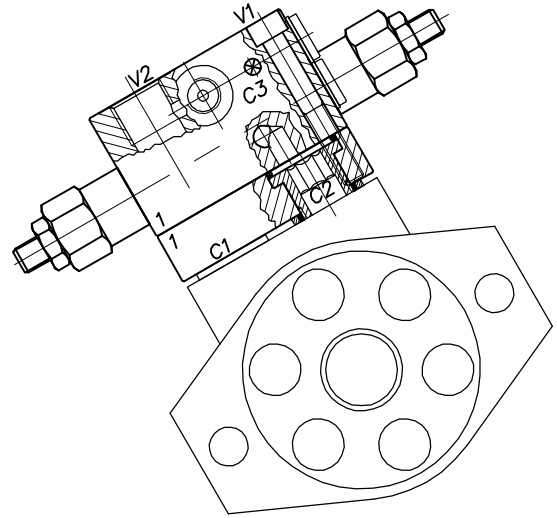
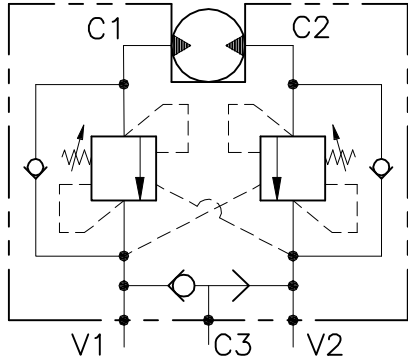

## CARATTERISTICHE

Luce nominale	<b>DN 10</b>
Portata min/max	<b>1/60 l/min - 0.26/15.9 GPM</b>
Pressione max. di picco	<b>350 bar - 5075 PSI</b>
Pressione max. di taratura	<b>220 bar - 3190 PSI</b>
Rapporto di pilotaggio standard	<b>4.25 : 1</b>
Temperatura ambiente	<b>-30°C + 50°C</b>
Temperatura olio	<b>-30°C + 80°C</b>
Filtraggio consigliato	<b>30 micron</b>
Coppia di serraggio	<b>70÷80 Nm</b>
Peso	

## PERFORMANCE

Rated size
Min/max flow-rate
Max peak pressure
Max setting pressure
Standard pilot ratio
Room temperature
Oil temperature
Recommended filtration
Tightening torque
Weight

### NOTE:

La taratura deve essere **1.3** volte maggiore della pressione indotta dal carico.

Valve should be set at **1.3** times load induced pressure.

### ESEMPIO/EXAMPLE:

Pressione di lavoro max:  
Max working pressure:  
**350 bar / 1.3 = 270 bar**

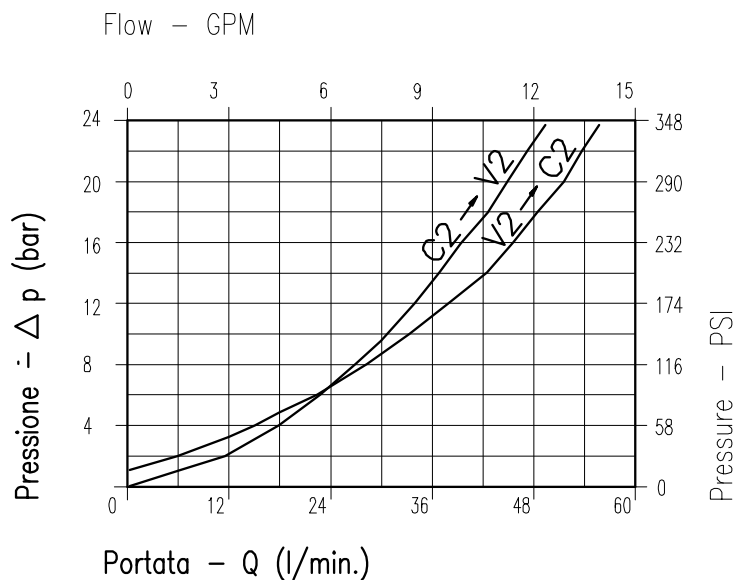

REGOLAZIONE  
ADJUSTMENT →

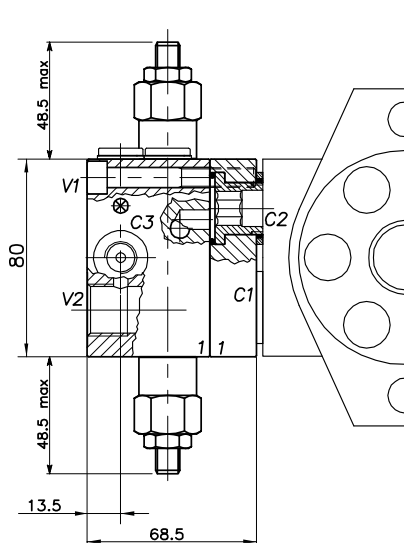

Grano  
Dowel  
(X)

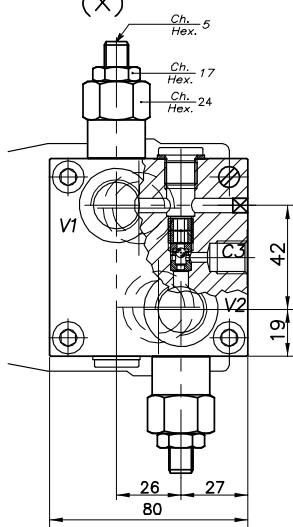

Piombata  
Sealed  
(K)

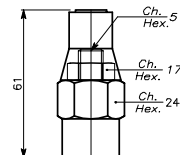

## DIMENSIONI DIMENSIONS

## ESEMPIO TIPICO DI CIRCUITO TYPICAL CIRCUIT EXAMPLE

Campo taratura Setting range	Attacchi Port size V2-C2 V1-C1 GAS (BSPP)	Attacchi Port size C3 GAS (BSPP)	Tipo motore Motor type
436	1/2"	1/4"	Samhydraulik AG-BG-AR (40x8)
437	1/2"	1/4"	Olidrive (44x17)
438	1/2"	1/4"	Samhydraulik HPR-HPRC Danfoss OMS (32x22)
439	1/2"	1/4"	Danfoss OMR-OMP (36x36)
656	1/2"	1/4"	Char Lynn (45,7) TRW MAC/MAF

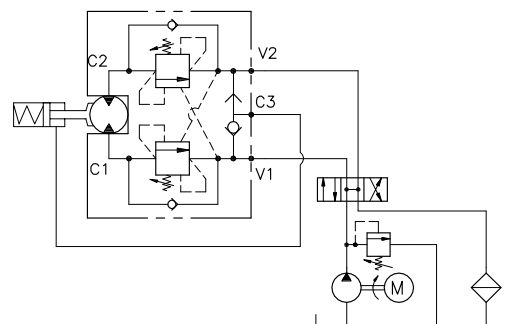

## CODICE DI ORDINAZIONE HOW TO ORDER

N01 . 436 . 0 X 0 . A

Campo taratura / Setting range
436
437
438
439
656

Campo taratura 30÷220 bar (molla colore verde)  
Setting range 30÷220 bar (green spring)

Taratura standard  
(Q=5 l/1')  
Std. bar setting  
(Q=5 l/1')  
**180 bar**

Incr. press. -  
bar giro/vite  
Pressure rise -  
turn of screw  
**(50)**

Rapporto di pilotaggio  
Pilot ratios

O 4.25 : 1  
D 8 : 1

Regolazione  
Adjustment

X Grano - Dowel  
K Piombata - Sealed

Collettore  
Body

A Acciaio zincato  
Zinc plated steel

436	Collettore possibile in AL togliendo "A" Available aluminium body without "A"
437	
438	
439	
656	

# WB-M-DE-VFF-...-12-14-...

VALVOLA BILANCIAMENTO, BLOCCO E CONTROLLO MOVIMENTO A DOPPIO EFFETTO FLANGIATA MOTORE CON VALVOLE DI MASSIMA

DOUBLE COUNTERBALANCE MOTOR FLANGEABLE VALVE

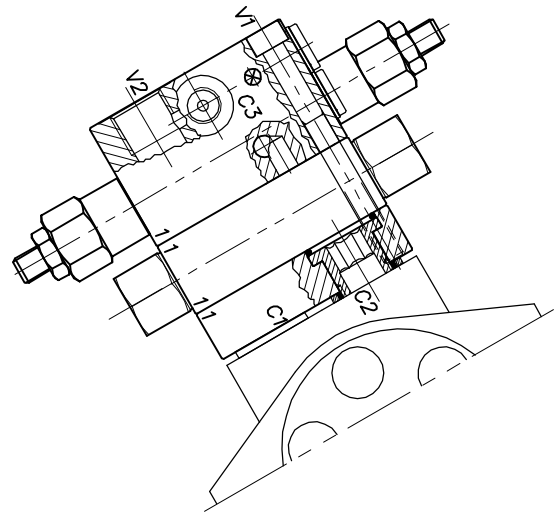
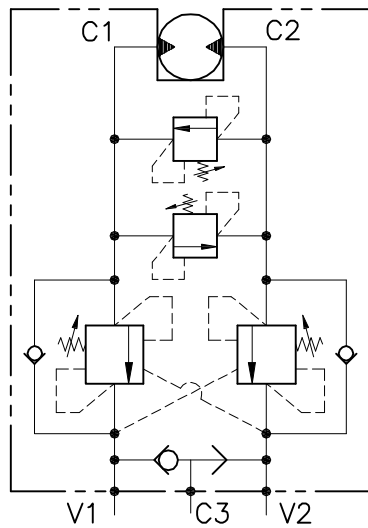

## CARATTERISTICHE

Luce nominale	<b>DN 10</b>
Portata min/max	<b>1/60 l/min - 0.26/15.9 GPM</b>
Pressione max. di picco	<b>350 bar - 5075 PSI</b>
Pressione max. di taratura	<b>220 bar - 3190 PSI</b>
Rapporto di pilotaggio standard	<b>4.25 : 1</b>
Temperatura ambiente	<b>-30°C + 50°C</b>
Temperatura olio	<b>-30°C + 80°C</b>
Filtraggio consigliato	<b>30 micron</b>
Coppia di serraggio	<b>110÷115 Nm</b>
Peso	

## PERFORMANCE

Rated size
Min/max flow-rate
Max peak pressure
Max setting pressure
Standard pilot ratio
Room temperature
Oil temperature
Recommended filtration
Tightening torque
Weight

### NOTE:

La taratura deve essere **1.3** volte maggiore della pressione indotta dal carico.

Valve should be set at **1.3** times load induced pressure.

### ESEMPIO/EXAMPLE:

Pressione di lavoro max:

Max working pressure:

**350 bar / 1.3 = 270 bar**

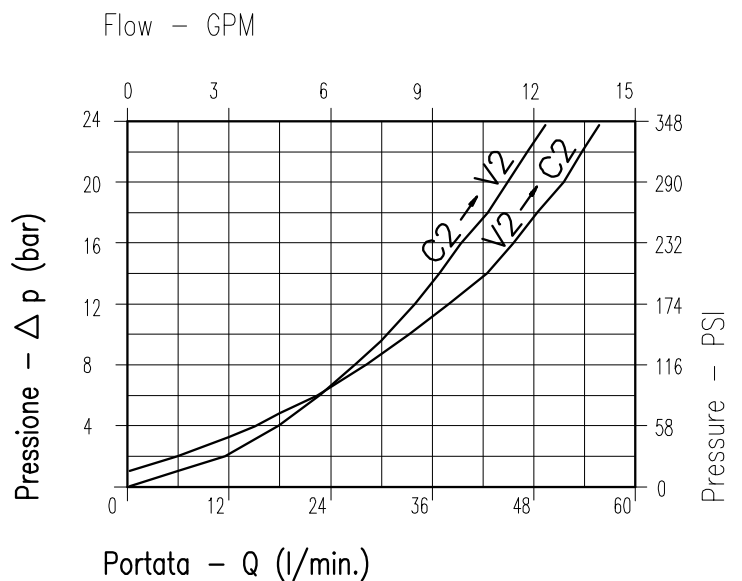

Viscosità olio 46 cSt a 50°C  
Oil viscosity 46 cSt at 50°C

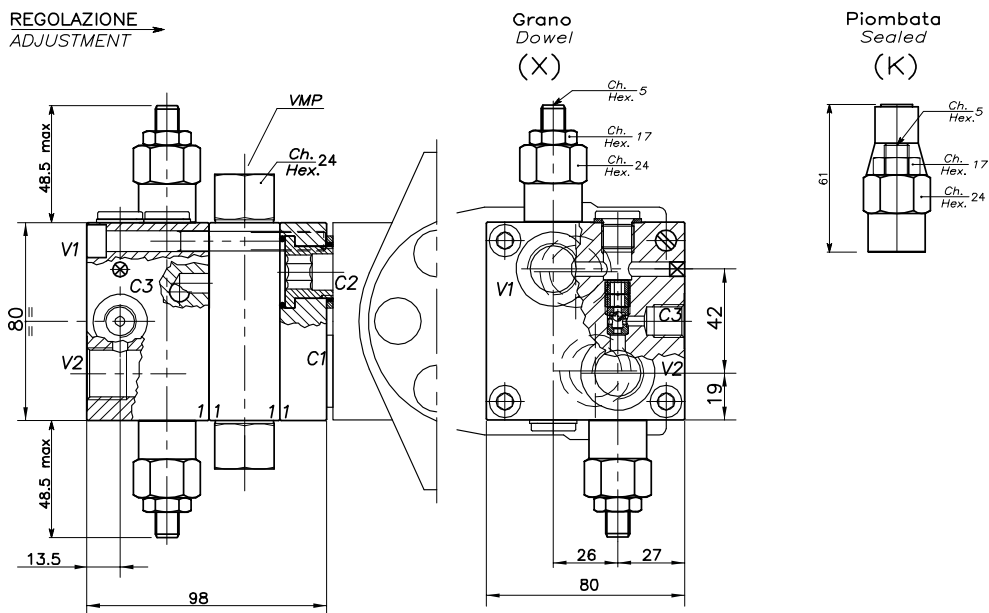

## DIMENSIONI DIMENSIONS

## ESEMPIO TIPICO DI CIRCUITO TYPICAL CIRCUIT EXAMPLE

Campo taratura Setting range	Attacchi Port size V2-C2 V1-C1 GAS (BSPP)	Attacchi Port size C3 GAS (BSPP)	Tipo motore Motor type	
440	1/2"	1/4"	Samhydraulik AG-BG-AR (40x8)	FSH
441	1/2"	1/4"	Olidrive (44x17)	FOLD
442	1/2"	1/4"	Samhydraulik HPR-HPRC Danfoss OMS (32x22)	FOMS
443	1/2"	1/4"	Danfoss OMR-OMP (36x36)	FOMR-OMP

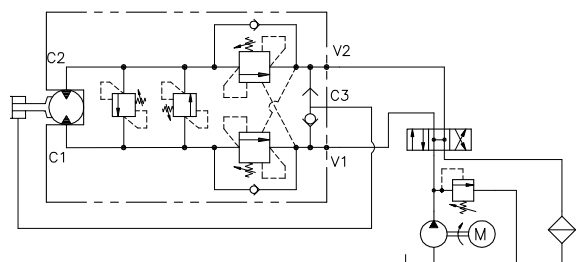

## CODICE DI ORDINAZIONE HOW TO ORDER

N01 . 440 . 0 X 0 . A

Campo taratura / Setting range			
WB)	440	(VMP)	
WB)	441	(VMP)	
WB)	442	(VMP)	
WB)	443	(VMP)	
Campo taratura 30÷220 bar (molla colore verde) Setting range 30÷220 bar (green spring)		Campo taratura 60÷350 bar (molla colore giallo) Setting range 60÷350 bar (yellow spring)	
Taratura standard (Q=5 l/1')	Incr. press. - bar giro/vite	Taratura standard (Q=5 l/1')	Incr. press. - bar giro/vite
Std. bar setting (Q=5 l/1')	Pressure rise - turn of screw	Std. bar setting (Q=5 l/1')	Pressure rise - turn of screw
<b>180 bar</b>	<b>(50)</b>	<b>250 bar</b>	<b>(90)</b>

Rapporto di pilotaggio Pilot ratios	Regolazione Adjustment	Collettore Body
O 4.25 : 1	X Grano - Dowel	A Acciaio zincato Zinc plated steel
D 8 : 1	K Piombata - Sealed	

442	
443	Collettore possibile in AL togliendo "A"
440	Available aluminium body without "A"
441	

# NOTES



Hydraulic valves and integrated components

A series of horizontal light blue lines providing a template for handwritten notes.

# NOTES



Hydraulic valves and integrated components

A series of horizontal light blue lines providing a template for handwritten notes.

